



**COMMONWEALTH OF PENNSYLVANIA
DEPARTMENT OF ENVIRONMENTAL PROTECTION
AIR QUALITY PROGRAM**

TITLE V/STATE OPERATING PERMIT

Issue Date:	March 16, 2020	Effective Date:	November 15, 2022
Revision Date:	November 14, 2022	Expiration Date:	March 31, 2025
Revision Type:	Modification		

In accordance with the provisions of the Air Pollution Control Act, the Act of January 8, 1960, P.L. 2119, as amended, and 25 Pa. Code Chapter 127, the Owner, [and Operator if noted] (hereinafter referred to as permittee) identified below is authorized by the Department of Environmental Protection (Department) to operate the air emission source(s) more fully described in this permit. This Facility is subject to all terms and conditions specified in this permit. Nothing in this permit relieves the permittee from its obligations to comply with all applicable Federal, State and Local laws and regulations.

The regulatory or statutory authority for each permit condition is set forth in brackets. All terms and conditions in this permit are federally enforceable applicable requirements unless otherwise designated as "State-Only" or "non-applicable" requirements.

TITLE V Permit No: 67-05005

Federal Tax Id - Plant Code: 23-3022596-5

Owner Information

Name: BRUNNER ISLAND LLC
Mailing Address: PO BOX 221
YORK HAVEN, PA 17370

Plant Information

Plant: BRUNNER ISLAND LLC/BRUNNER ISLAND
Location: 67 York County 67917 East Manchester Township
SIC Code: 4911 Trans. & Utilities - Electric Services

Responsible Official

Name: THOMAS CLISHAM
Title: PLANT MGR
Phone: (717) 266 - 7510 Email: thomas.clisham@talenergy.com

Permit Contact Person

Name: MARCIA W THIESS
Title: REGULATORY AFFAIRS SR PRO
Phone: (717) 268 - 1531 Email: Marcia.Thiess@talenergy.com

[Signature] _____
WILLIAM R. WEAVER, SOUTH CENTRAL REGION AIR PROGRAM MANAGER



SECTION A. Table of Contents

Section A. Facility/Source Identification

Table of Contents
Site Inventory List

Section B. General Title V Requirements

- #001 Definitions
- #002 Prohibition of Air Pollution
- #003 Property Rights
- #004 Permit Expiration
- #005 Permit Renewal
- #006 Transfer of Ownership or Operational Control
- #007 Inspection and Entry
- #008 Compliance Requirements
- #009 Need to Halt or Reduce Activity Not a Defense
- #010 Duty to Provide Information
- #011 Reopening and Revising the Title V Permit for Cause
- #012 Reopening a Title V Permit for Cause by EPA
- #013 Operating Permit Application Review by the EPA
- #014 Significant Operating Permit Modifications
- #015 Minor Operating Permit Modifications
- #016 Administrative Operating Permit Amendments
- #017 Severability Clause
- #018 Fee Payment
- #019 Authorization for De Minimis Emission Increases
- #020 Reactivation of Sources
- #021 Circumvention
- #022 Submissions
- #023 Sampling, Testing and Monitoring Procedures
- #024 Compliance Certification
- #025 Recordkeeping Requirements
- #026 Reporting Requirements
- #027 Operational Flexibility
- #028 Risk Management
- #029 Approved Economic Incentives and Emission Trading Programs
- #030 Permit Shield
- #031 Reporting
- #032 Report Format

Section C. Site Level Title V Requirements

- C-I: Restrictions
- C-II: Testing Requirements
- C-III: Monitoring Requirements
- C-IV: Recordkeeping Requirements
- C-V: Reporting Requirements
- C-VI: Work Practice Standards
- C-VII: Additional Requirements
- C-VIII: Compliance Certification
- C-IX: Compliance Schedule

Section D. Source Level Title V Requirements

- D-I: Restrictions
- D-II: Testing Requirements
- D-III: Monitoring Requirements
- D-IV: Recordkeeping Requirements
- D-V: Reporting Requirements



SECTION A. Table of Contents

D-VI: Work Practice Standards
D-VII: Additional Requirements

Note: These same sub-sections are repeated for each source!

Section E. Source Group Restrictions

E-I: Restrictions
E-II: Testing Requirements
E-III: Monitoring Requirements
E-IV: Recordkeeping Requirements
E-V: Reporting Requirements
E-VI: Work Practice Standards
E-VII: Additional Requirements

Section F. Alternative Operating Scenario(s)

F-I: Restrictions
F-II: Testing Requirements
F-III: Monitoring Requirements
F-IV: Recordkeeping Requirements
F-V: Reporting Requirements
F-VI: Work Practice Standards
F-VII: Additional Requirements

Section G. Emission Restriction Summary

Section H. Miscellaneous

**SECTION A. Site Inventory List**

Source ID	Source Name	Capacity/Throughput		Fuel/Material
031A	BRUNNER ISLAND UNIT 1	3,345.000	MMBTU/HR	
		134.000	Tons/HR	Bituminous
		4,960.000	Gal/HR	#2 Oil
		3,345.000	MCF/HR	Natural Gas
032	BRUNNER ISLAND UNIT 2	3,800.000	MMBTU/HR	
		5,760.000	Gal/HR	#2 Oil
		3,800.000	MCF/HR	Natural Gas
		152.000	Tons/HR	Bituminous
033A	BRUNNER ISLAND UNIT 3	7,329.000	MMBTU/HR	
		289.600	Tons/HR	Bituminous
		8,600.000	Gal/HR	#2 Oil
		7,329.000	MCF/HR	Natural Gas
034	G-M DIESEL GENERATOR 1	26.200	MMBTU/HR	
037	DIESEL- FIRED QUENCH PUMP 1	4.027	MMBTU/HR	
		30.000	Gal/HR	Diesel Fuel
038	DIESEL- FIRED QUENCH PUMP 2	4.027	MMBTU/HR	
		30.000	Gal/HR	Diesel Fuel
050	FOUR NG-FIRED NG PIPELINE HEATERS	30.400	MMBTU/HR	
		30.400	MCF/HR	NATURAL GAS (TOTAL)
101	ROADWAYS			
110	RAILCAR UNLOADING OPERATION	1,600.000	Tons/HR	COAL
127	DRY ASH HANDLING SYSTEM	132.000	Tons/HR	DRY ASH HANDLED
131	LIMESTONE MATERIAL HANDLING OPERATIONS	2,000.000	Tons/HR	LIMESTONE
132	GYPSUM MATERIAL HANDLING OPERATIONS	270.000	Tons/HR	SYNTHETIC GYPSUM
133	WWTP LIME STORAGE SILO		N/A	
140	UNITS 1/2 MERCURY DRY SORBENT STORAGE SILO		N/A	
141	UNIT 3 MERCURY DRY SORBENT STORAGE SILO		N/A	
150	REFINED COAL SYSTEM		N/A	
201	REMOTE RESERVOIR COLD CLEANING MACHINES	1.000	Lbs/HR	VOC
301	NATURAL GAS PIPELINE (PROCESS)		N/A	Natural Gas
401	UNIT 1 EMERGENCY ENGINE			
402	UNIT 3 EMERGENCY ENGINE			
403	EMERGENCY SUMP PUMP ENGINE			
404	SERVICE WATER PUMP #3 ENGINE			
C01	UNIT 1 CARBORUNDUM BAGHOUSE			
C04	SILO A BIN VENT FILTER			
C05	SILO B BIN VENT FILTER			
C110	SOURCE 110 WET SUPPRESSION SYSTEM			
C127	SOURCE 127 WET SUPPRESSION SYSTEM			
C127A1	SOURCE 127 FABRIC COLLECTOR A-1			

**SECTION A. Site Inventory List**

Source ID	Source Name	Capacity/Throughput	Fuel/Material
C127A2	SOURCE 127 FABRIC COLLECTOR A-2		
C127B1	SOURCE 127 FABRIC COLLECTOR B-1		
C127B2	SOURCE 127 FABRIC COLLECTOR B-2		
C127L	SOURCE 127 BIN VENT COLLECTOR (LIME SILO)		
C131	DSI DRY FOGGER - TRAIN UNLOADING		
C131A	DSI DRY FOGGER - RECLAIM OPERATIONS		
C132	SOURCE 132 WET SUPPRESSION SYSTEM		
C133	WWTP LIME SILO DUST COLLECTOR		
C140	SOURCE 140 BIN VENT COLLECTOR		
C141	SOURCE 141 BIN VENT COLLECTOR		
C150A	30-TON SOLID SORBENT DAY STORAGE BIN - BIN VENT COLLECTOR		
C150B	20-TON SOLID SORBENT DAY STORAGE BIN - BIN VENT COLLECTOR		
C150C	150-TON SOLID SORBENT BULK STORAGE SILO - BIN VENT COLLECTOR		
C27A3A	SOURCE 127 FABRIC COLLECTOR A3A/3C		
C27A3B	SOURCE 127 FABRIC COLLECTOR A3B/3D		
C27B3A	SOURCE 127 FABRIC COLLECTOR B3A/3C		
C27B3B	SOURCE 127 FABRIC COLLECTOR B3B/3D		
D02A	UNIT 2 HAMON RESEARCH COTTRELL ESP		
D140A	UNITS 1/2 MERCURY DRY SORBENT INJECTION SYSTEM (UNIT 1)		
D140B	UNITS 1/2 MERCURY DRY SORBENT INJECTION SYSTEM (UNIT 2)		
D141	UNIT 3 MERCURY DRY SORBENT INJECTION SYSTEM		
E01	FGD SCRUBBER 1		
E03	FGD SCRUBBER 2		
P03A	UNIT #3 HRC ESP (3A)		
P03B	UNIT #3 HRC ESP (3B)		
P03C	UNIT #3 LODGE-COTTRELL ESP (3C)		
P03D	UNIT #3 LODGE-COTTRELL ESP (3D)		
FM02	NO. 2 FUEL OIL SUPPLY		
FM42	BITUMINOUS COAL SUPPLY		
FML037	NO. 2 FUEL OIL QUENCH PUMP NO. 1		
FML038	NO. 2 FUEL OIL QUENCH PUMP NO. 2		
FML25	NATURAL GAS PIPELINE (FML)		
S01A	UNIT 1/2 FGD SCRUBBER EXHAUST		
S03B	UNIT 3 FGD SCRUBBER EXHAUST		
S050A	SOURCE 050 STACK		
S050B	SOURCE 050 STACK		
S050C	SOURCE 050 STACK		
S050D	SOURCE 050 STACK		

**SECTION A. Site Inventory List**

Source ID	Source Name	Capacity/Throughput	Fuel/Material
S07	SILO A STACK		
S08	SILO B STACK		
S09	QUENCH PUMP 1 STACK		
S10	QUENCH PUMP 2 STACK		
S127A1	SOURCE 127 STACK (C127A1)		
S127A2	SOURCE 127 STACK (C127A2)		
S127B1	SOURCE 127 STACK (C127B1)		
S127B2	SOURCE 127 STACK (C127B2)		
S127L	SOURCE 127 STACK (C127L)		
S133	WWTP LIME SILO STACK		
S140	SOURCE C140 STACK		
S141	SOURCE C141 STACK		
S150A	SOURCE C150A STACK		
S150B	SOURCE C150B STACK		
S150C	SOURCE C150C STACK		
S27A3A	SOURCE 127 STACK (C27A3A)		
S27A3B	SOURCE 127 STACK (C27A3B)		
S27B3A	SOURCE 127 STACK (C27B3A)		
S27B3B	SOURCE 127 STACK (C27B3B)		
S401	SOURCE 401 STACK		
S402	SOURCE 402 STACK		
S403	SOURCE 403 STACK		
S404	SOURCE 404 STACK		
Z110	SOURCE 110 FUGITIVE EMISSIONS		
Z127	SOURCE 127 FUGITIVE EMISSIONS		
Z131	FUGITIVE EMISSIONS - LIMESTONE HANDLING		
Z131A	SOURCE C131A FUGITIVE EMISSIONS		
Z131Z	SOURCE C131 FUGITIVE EMISSIONS		
Z132	FUGITIVE EMISSIONS - GYPSUM HANDLING		
Z201	SOURCE 201 FUGITIVE EMISSIONS		
Z301	SOURCE 301 FUGITIVE EMISSIONS		

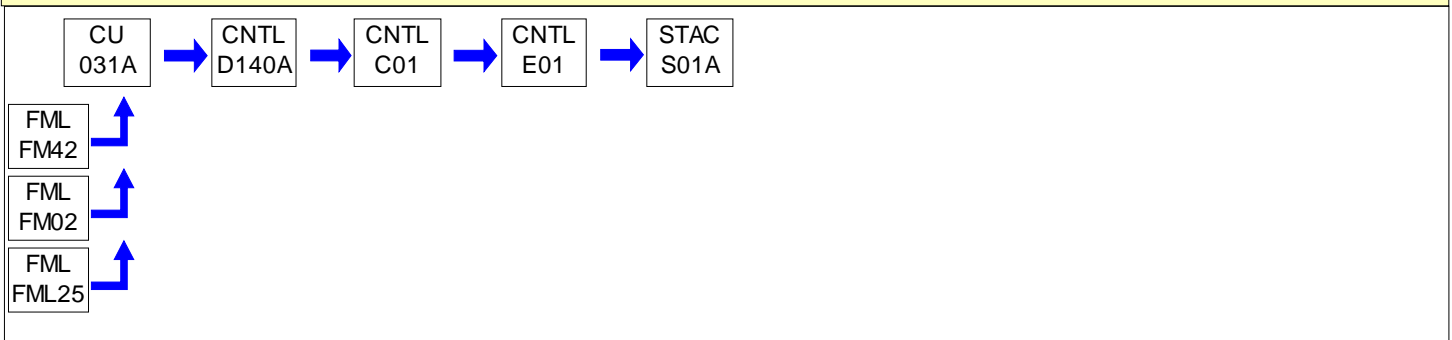
PERMIT MAPS



PERMIT MAPS

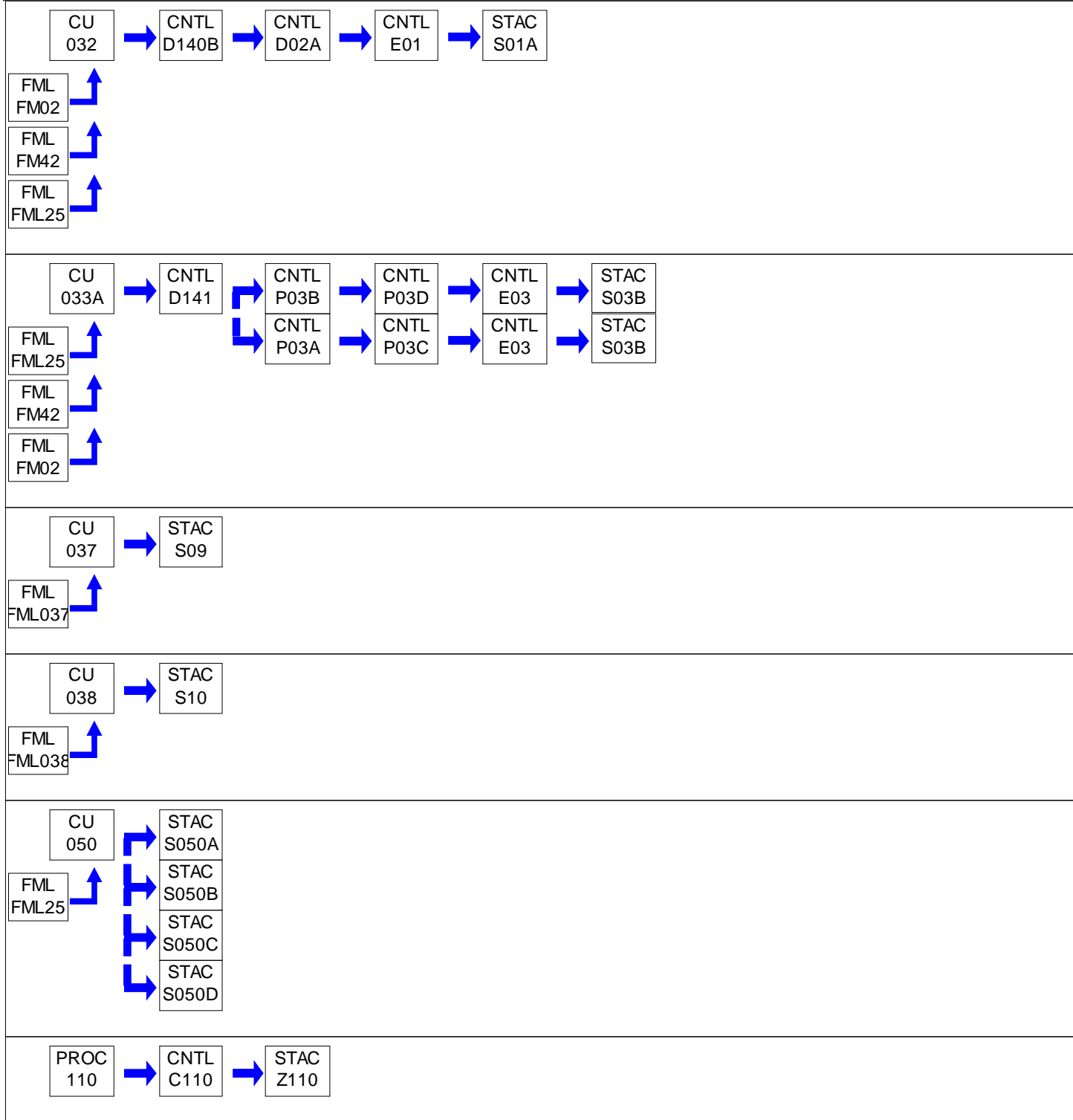



PERMIT MAPS

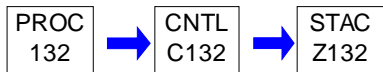
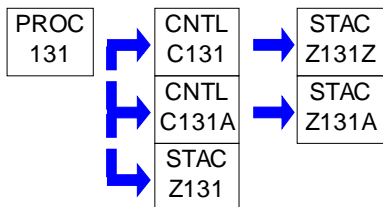
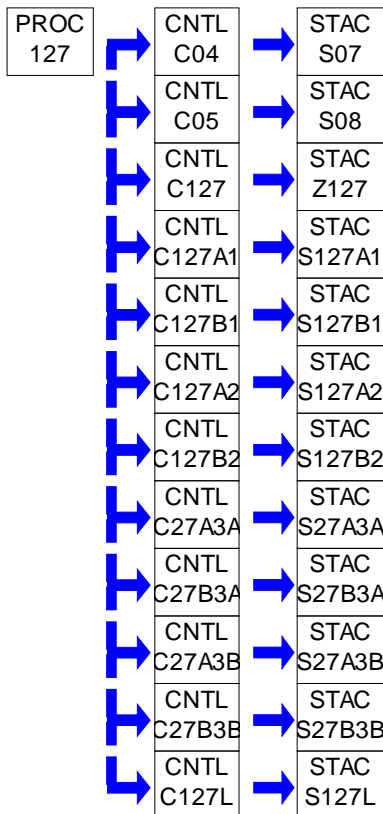

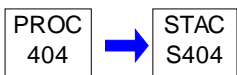
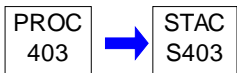
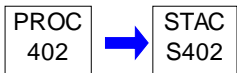
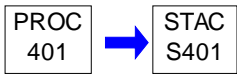
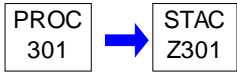
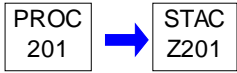
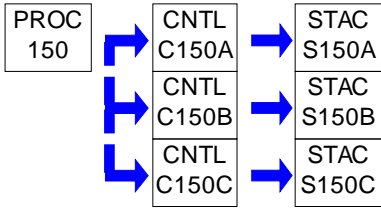
**PERMIT MAPS**

**SECTION B. General Title V Requirements****#001 [25 Pa. Code § 121.1]****Definitions**

Words and terms that are not otherwise defined in this permit shall have the meanings set forth in Section 3 of the Air Pollution Control Act (35 P.S. § 4003) and 25 Pa. Code § 121.1.

#002 [25 Pa. Code § 121.7]**Prohibition of Air Pollution**

No person may permit air pollution as that term is defined in the act.

#003 [25 Pa. Code § 127.512(c)(4)]**Property Rights**

This permit does not convey property rights of any sort, or any exclusive privileges.

#004 [25 Pa. Code § 127.446(a) and (c)]**Permit Expiration**

This operating permit is issued for a fixed term of five (5) years and shall expire on the date specified on Page 1 of this permit. The terms and conditions of the expired permit shall automatically continue pending issuance of a new Title V permit, provided the permittee has submitted a timely and complete application and paid applicable fees required under 25 Pa. Code Chapter 127, Subchapter I and the Department is unable, through no fault of the permittee, to issue or deny a new permit before the expiration of the previous permit. An application is complete if it contains sufficient information to begin processing the application, has the applicable sections completed and has been signed by a responsible official.

#005 [25 Pa. Code §§ 127.412, 127.413, 127.414, 127.446(e), 127.503 & 127.704(b)]**Permit Renewal**

(a) An application for the renewal of the Title V permit shall be submitted to the Department at least six (6) months, and not more than 18 months, before the expiration date of this permit. The renewal application is timely if a complete application is submitted to the Department's Regional Air Manager within the timeframe specified in this permit condition.

(b) The application for permit renewal shall include the current permit number, the appropriate permit renewal fee, a description of any permit revisions and off-permit changes that occurred during the permit term, and any applicable requirements that were promulgated and not incorporated into the permit during the permit term. The fees shall be made payable to "The Commonwealth of Pennsylvania Clean Air Fund" and submitted with the fee form to the respective regional office.

(c) The renewal application shall also include submission of proof that the local municipality and county, in which the facility is located, have been notified in accordance with 25 Pa. Code § 127.413. The application for renewal of the Title V permit shall also include submission of compliance review forms which have been used by the permittee to update information submitted in accordance with either 25 Pa. Code § 127.412(b) or § 127.412(j).

(d) The permittee, upon becoming aware that any relevant facts were omitted or incorrect information was submitted in the permit application, shall promptly submit such supplementary facts or corrected information during the permit renewal process. The permittee shall also promptly provide additional information as necessary to address any requirements that become applicable to the source after the date a complete renewal application was submitted but prior to release of a draft permit.

#006 [25 Pa. Code §§ 127.450(a)(4) & 127.464(a)]**Transfer of Ownership or Operational Control**

(a) In accordance with 25 Pa. Code § 127.450(a)(4), a change in ownership or operational control of the source shall be treated as an administrative amendment if:

(1) The Department determines that no other change in the permit is necessary;

(2) A written agreement has been submitted to the Department identifying the specific date of the transfer of permit responsibility, coverage and liability between the current and the new permittee; and,

(3) A compliance review form has been submitted to the Department and the permit transfer has been approved by

**SECTION B. General Title V Requirements**

the Department.

(b) In accordance with 25 Pa. Code § 127.464(a), this permit may not be transferred to another person except in cases of transfer-of-ownership which are documented and approved to the satisfaction of the Department.

#007 [25 Pa. Code § 127.513, 35 P.S. § 4008 and § 114 of the CAA]**Inspection and Entry**

(a) Upon presentation of credentials and other documents as may be required by law for inspection and entry purposes, the permittee shall allow the Department of Environmental Protection or authorized representatives of the Department to perform the following:

- (1) Enter at reasonable times upon the permittee's premises where a Title V source is located or emissions related activity is conducted, or where records are kept under the conditions of this permit;
- (2) Have access to and copy or remove, at reasonable times, records that are kept under the conditions of this permit;
- (3) Inspect at reasonable times, facilities, equipment including monitoring and air pollution control equipment, practices, or operations regulated or required under this permit;
- (4) Sample or monitor, at reasonable times, substances or parameters, for the purpose of assuring compliance with the permit or applicable requirements as authorized by the Clean Air Act, the Air Pollution Control Act, or the regulations promulgated under the Acts.

(b) Pursuant to 35 P.S. § 4008, no person shall hinder, obstruct, prevent or interfere with the Department or its personnel in the performance of any duty authorized under the Air Pollution Control Act.

(c) Nothing in this permit condition shall limit the ability of the EPA to inspect or enter the premises of the permittee in accordance with Section 114 or other applicable provisions of the Clean Air Act.

#008 [25 Pa. Code §§ 127.25, 127.444, & 127.512(c)(1)]**Compliance Requirements**

(a) The permittee shall comply with the conditions of this permit. Noncompliance with this permit constitutes a violation of the Clean Air Act and the Air Pollution Control Act and is grounds for one (1) or more of the following:

- (1) Enforcement action
- (2) Permit termination, revocation and reissuance or modification
- (3) Denial of a permit renewal application

(b) A person may not cause or permit the operation of a source, which is subject to 25 Pa. Code Article III, unless the source(s) and air cleaning devices identified in the application for the plan approval and operating permit and the plan approval issued to the source are operated and maintained in accordance with specifications in the applications and the conditions in the plan approval and operating permit issued by the Department. A person may not cause or permit the operation of an air contamination source subject to 25 Pa. Code Chapter 127 in a manner inconsistent with good operating practices.

(c) For purposes of Sub-condition (b) of this permit condition, the specifications in applications for plan approvals and operating permits are the physical configurations and engineering design details which the Department determines are essential for the permittee's compliance with the applicable requirements in this Title V permit.

#009 [25 Pa. Code § 127.512(c)(2)]**Need to Halt or Reduce Activity Not a Defense**

It shall not be a defense for a permittee in an enforcement action that it would have been necessary to halt or reduce the permitted activity in order to maintain compliance with the conditions of this permit.

**SECTION B. General Title V Requirements****#010 [25 Pa. Code §§ 127.411(d) & 127.512(c)(5)]****Duty to Provide Information**

(a) The permittee shall furnish to the Department, within a reasonable time, information that the Department may request in writing to determine whether cause exists for modifying, revoking and reissuing, or terminating the permit, or to determine compliance with the permit.

(b) Upon request, the permittee shall also furnish to the Department copies of records that the permittee is required to keep by this permit, or for information claimed to be confidential, the permittee may furnish such records directly to the Administrator of EPA along with a claim of confidentiality.

#011 [25 Pa. Code §§ 127.463, 127.512(c)(3) & 127.542]**Reopening and Revising the Title V Permit for Cause**

(a) This Title V permit may be modified, revoked, reopened and reissued or terminated for cause. The filing of a request by the permittee for a permit modification, revocation and reissuance, or termination, or of a notification of planned changes or anticipated noncompliance does not stay a permit condition.

(b) This permit may be reopened, revised and reissued prior to expiration of the permit under one or more of the following circumstances:

(1) Additional applicable requirements under the Clean Air Act or the Air Pollution Control Act become applicable to a Title V facility with a remaining permit term of three (3) or more years prior to the expiration date of this permit. The Department will revise the permit as expeditiously as practicable but not later than 18 months after promulgation of the applicable standards or regulations. No such revision is required if the effective date of the requirement is later than the expiration date of this permit, unless the original permit or its terms and conditions has been extended.

(2) Additional requirements, including excess emissions requirements, become applicable to an affected source under the acid rain program. Upon approval by the Administrator of EPA, excess emissions offset plans for an affected source shall be incorporated into the permit.

(3) The Department or the EPA determines that this permit contains a material mistake or inaccurate statements were made in establishing the emissions standards or other terms or conditions of this permit.

(4) The Department or the Administrator of EPA determines that the permit must be revised or revoked to assure compliance with the applicable requirements.

(c) Proceedings to revise this permit shall follow the same procedures which apply to initial permit issuance and shall affect only those parts of this permit for which cause to revise exists. The revision shall be made as expeditiously as practicable.

(d) Regardless of whether a revision is made in accordance with (b)(1) above, the permittee shall meet the applicable standards or regulations promulgated under the Clean Air Act within the time frame required by standards or regulations.

#012 [25 Pa. Code § 127.543]**Reopening a Title V Permit for Cause by EPA**

As required by the Clean Air Act and regulations adopted thereunder, this permit may be modified, reopened and reissued, revoked or terminated for cause by EPA in accordance with procedures specified in 25 Pa. Code § 127.543.

#013 [25 Pa. Code § 127.522(a)]**Operating Permit Application Review by the EPA**

The applicant may be required by the Department to provide a copy of the permit application, including the compliance plan, directly to the Administrator of the EPA. Copies of title V permit applications to EPA, pursuant to 25 PA Code §127.522(a), shall be submitted, if required, to the following EPA e-mail box:

R3_Air_Apps_and_Notices@epa.gov

Please place the following in the subject line: TV [permit number], [Facility Name].

**SECTION B. General Title V Requirements****#014 [25 Pa. Code § 127.541]****Significant Operating Permit Modifications**

When permit modifications during the term of this permit do not qualify as minor permit modifications or administrative amendments, the permittee shall submit an application for significant Title V permit modifications in accordance with 25 Pa. Code § 127.541. Notifications to EPA, pursuant to 25 PA Code §127.522(a), if required, shall be submitted, to the following EPA e-mail box:

R3_Air_Apps_and_Notices@epa.gov

Please place the following in the subject line: TV [permit number], [Facility Name].

#015 [25 Pa. Code §§ 121.1 & 127.462]**Minor Operating Permit Modifications**

The permittee may make minor operating permit modifications (as defined in 25 Pa. Code §121.1), on an expedited basis, in accordance with 25 Pa. Code §127.462 (relating to minor operating permit modifications). Notifications to EPA, pursuant to 25 PA Code §127.462(c), if required, shall be submitted, to the following EPA e-mail box:

R3_Air_Apps_and_Notices@epa.gov

Please place the following in the subject line: TV [permit number], [Facility Name].

#016 [25 Pa. Code § 127.450]**Administrative Operating Permit Amendments**

(a) The permittee may request administrative operating permit amendments, as defined in 25 Pa. Code §127.450(a). Copies of request for administrative permit amendment to EPA, pursuant to 25 PA Code §127.450(c)(1), if required, shall be submitted to the following EPA e-mail box:

R3_Air_Apps_and_Notices@epa.gov

Please place the following in the subject line: TV [permit number], [Facility Name].

(b) Upon final action by the Department granting a request for an administrative operating permit amendment covered under §127.450(a)(5), the permit shield provisions in 25 Pa. Code § 127.516 (relating to permit shield) shall apply to administrative permit amendments incorporated in this Title V Permit in accordance with §127.450(c), unless precluded by the Clean Air Act or the regulations thereunder.

#017 [25 Pa. Code § 127.512(b)]**Severability Clause**

The provisions of this permit are severable, and if any provision of this permit is determined by the Environmental Hearing Board or a court of competent jurisdiction, or US EPA to be invalid or unenforceable, such a determination will not affect the remaining provisions of this permit.

#018 [25 Pa. Code §§ 127.704, 127.705 & 127.707]**Fee Payment**

(a) The permittee shall pay fees to the Department in accordance with the applicable fee schedules in 25 Pa. Code Chapter 127, Subchapter I (relating to plan approval and operating permit fees). The applicable fees shall be made payable to "The Commonwealth of Pennsylvania Clean Air Fund" with the permit number clearly indicated and submitted to the respective regional office.

(b) Emission Fees. The permittee shall, on or before September 1st of each year, pay applicable annual Title V emission fees for emissions occurring in the previous calendar year as specified in 25 Pa. Code § 127.705. The permittee is not required to pay an emission fee for emissions of more than 4,000 tons of each regulated pollutant emitted from the facility.

(c) As used in this permit condition, the term "regulated pollutant" is defined as a VOC, each pollutant regulated under Sections 111 and 112 of the Clean Air Act and each pollutant for which a National Ambient Air Quality Standard has been promulgated, except that carbon monoxide is excluded.

**SECTION B. General Title V Requirements**

(d) Late Payment. Late payment of emission fees will subject the permittee to the penalties prescribed in 25 Pa. Code § 127.707 and may result in the suspension or termination of the Title V permit. The permittee shall pay a penalty of fifty percent (50%) of the fee amount, plus interest on the fee amount computed in accordance with 26 U.S.C.A. § 6621(a)(2) from the date the emission fee should have been paid in accordance with the time frame specified in 25 Pa. Code § 127.705(c).

(e) The permittee shall pay an annual operating permit maintenance fee according to the following fee schedule established in 25 Pa. Code § 127.704(d) on or before December 31 of each year for the next calendar year.

- (1) Eight thousand dollars (\$8,000) for calendar years 2021—2025.
- (2) Ten thousand dollars (\$10,000) for calendar years 2026—2030.
- (3) Twelve thousand five hundred dollars (\$12,500) for the calendar years beginning with 2031.

#019 [25 Pa. Code §§ 127.14(b) & 127.449]**Authorization for De Minimis Emission Increases**

(a) This permit authorizes de minimis emission increases from a new or existing source in accordance with 25 Pa. Code §§ 127.14 and 127.449 without the need for a plan approval or prior issuance of a permit modification. The permittee shall provide the Department with seven (7) days prior written notice before commencing any de minimis emissions increase that would result from either: (1) a physical change of minor significance under § 127.14(c)(1); or (2) the construction, installation, modification or reactivation of an air contamination source. The written notice shall:

- (1) Identify and describe the pollutants that will be emitted as a result of the de minimis emissions increase.
- (2) Provide emission rates expressed in tons per year and in terms necessary to establish compliance consistent with any applicable requirement.

The Department may disapprove or condition de minimis emission increases at any time.

(b) Except as provided below in (c) and (d) of this permit condition, the permittee is authorized during the term of this permit to make de minimis emission increases (expressed in tons per year) up to the following amounts without the need for a plan approval or prior issuance of a permit modification:

- (1) Four tons of carbon monoxide from a single source during the term of the permit and 20 tons of carbon monoxide at the facility during the term of the permit.
- (2) One ton of NO_x from a single source during the term of the permit and 5 tons of NO_x at the facility during the term of the permit.
- (3) One and six-tenths tons of the oxides of sulfur from a single source during the term of the permit and 8.0 tons of oxides of sulfur at the facility during the term of the permit.
- (4) Six-tenths of a ton of PM₁₀ from a single source during the term of the permit and 3.0 tons of PM₁₀ at the facility during the term of the permit. This shall include emissions of a pollutant regulated under Section 112 of the Clean Air Act unless precluded by the Clean Air Act or 25 Pa. Code Article III.
- (5) One ton of VOCs from a single source during the term of the permit and 5.0 tons of VOCs at the facility during the term of the permit. This shall include emissions of a pollutant regulated under Section 112 of the Clean Air Act unless precluded by the Clean Air Act or 25 Pa. Code Article III.

(c) In accordance with § 127.14, the permittee may install the following minor sources without the need for a plan approval:

- (1) Air conditioning or ventilation systems not designed to remove pollutants generated or released from other sources.
- (2) Combustion units rated at 2,500,000 or less Btu per hour of heat input.

**SECTION B. General Title V Requirements**

(3) Combustion units with a rated capacity of less than 10,000,000 Btu per hour heat input fueled by natural gas supplied by a public utility, liquefied petroleum gas or by commercial fuel oils which are No. 2 or lighter, viscosity less than or equal to 5.82 c St, and which meet the sulfur content requirements of 25 Pa. Code § 123.22 (relating to combustion units). For purposes of this permit, commercial fuel oil shall be virgin oil which has no reprocessed, recycled or waste material added.

(4) Space heaters which heat by direct heat transfer.

(5) Laboratory equipment used exclusively for chemical or physical analysis.

(6) Other sources and classes of sources determined to be of minor significance by the Department.

(d) This permit does not authorize de minimis emission increases if the emissions increase would cause one or more of the following:

(1) Increase the emissions of a pollutant regulated under Section 112 of the Clean Air Act except as authorized in Subparagraphs (b)(4) and (5) of this permit condition.

(2) Subject the facility to the prevention of significant deterioration requirements in 25 Pa. Code Chapter 127, Subchapter D and/or the new source review requirements in Subchapter E.

(3) Violate any applicable requirement of the Air Pollution Control Act, the Clean Air Act, or the regulations promulgated under either of the acts.

(4) Changes which are modifications under any provision of Title I of the Clean Air Act and emission increases which would exceed the allowable emissions level (expressed as a rate of emissions or in terms of total emissions) under the Title V permit.

(e) Unless precluded by the Clean Air Act or the regulations thereunder, the permit shield described in 25 Pa. Code § 127.516 (relating to permit shield) shall extend to the changes made under 25 Pa. Code § 127.449 (relating to de minimis emission increases).

(f) Emissions authorized under this permit condition shall be included in the monitoring, recordkeeping and reporting requirements of this permit.

(g) Except for de minimis emission increases allowed under this permit, 25 Pa. Code § 127.449, or sources and physical changes meeting the requirements of 25 Pa. Code § 127.14, the permittee is prohibited from making physical changes or engaging in activities that are not specifically authorized under this permit without first applying for a plan approval. In accordance with § 127.14(b), a plan approval is not required for the construction, modification, reactivation, or installation of the sources creating the de minimis emissions increase.

(h) The permittee may not meet de minimis emission threshold levels by offsetting emission increases or decreases at the same source.

#020 [25 Pa. Code §§ 127.11a & 127.215]**Reactivation of Sources**

(a) The permittee may reactivate a source at the facility that has been out of operation or production for at least one year, but less than or equal to five (5) years, if the source is reactivated in accordance with the requirements of 25 Pa. Code §§ 127.11a and 127.215. The reactivated source will not be considered a new source.

(b) A source which has been out of operation or production for more than five (5) years but less than 10 years may be reactivated and will not be considered a new source if the permittee satisfies the conditions specified in 25 Pa. Code § 127.11a(b).

#021 [25 Pa. Code §§ 121.9 & 127.216]**Circumvention**

(a) The owner of this Title V facility, or any other person, may not circumvent the new source review requirements of 25 Pa. Code Chapter 127, Subchapter E by causing or allowing a pattern of ownership or development, including the

**SECTION B. General Title V Requirements**

phasing, staging, delaying or engaging in incremental construction, over a geographic area of a facility which, except for the pattern of ownership or development, would otherwise require a permit or submission of a plan approval application.

(b) No person may permit the use of a device, stack height which exceeds good engineering practice stack height, dispersion technique or other technique which, without resulting in reduction of the total amount of air contaminants emitted, conceals or dilutes an emission of air contaminants which would otherwise be in violation of this permit, the Air Pollution Control Act or the regulations promulgated thereunder, except that with prior approval of the Department, the device or technique may be used for control of malodors.

#022 [25 Pa. Code §§ 127.402(d) & 127.513(1)]**Submissions**

(a) Reports, test data, monitoring data, notifications and requests for renewal of the permit shall be submitted to the:

Regional Air Program Manager
PA Department of Environmental Protection
(At the address given on the permit transmittal letter, or otherwise notified)

(b) Any report or notification for the EPA Administrator or EPA Region III should be addressed to:

Enforcement & Compliance Assurance Division
Air, RCRA and Toxics Branch (3ED21)
Four Penn Center
1600 John F. Kennedy Boulevard
Philadelphia, PA 19103-2852

The Title V compliance certification shall be emailed to EPA at R3_APD_Permits@epa.gov.

(c) An application, form, report or compliance certification submitted pursuant to this permit condition shall contain certification by a responsible official as to truth, accuracy, and completeness as required under 25 Pa. Code § 127.402(d). Unless otherwise required by the Clean Air Act or regulations adopted thereunder, this certification and any other certification required pursuant to this permit shall state that, based on information and belief formed after reasonable inquiry, the statements and information in the document are true, accurate and complete.

#023 [25 Pa. Code §§ 127.441(c) & 127.463(e); Chapter 139; & 114(a)(3), 504(b) of the CAA]**Sampling, Testing and Monitoring Procedures**

(a) The permittee shall perform the emissions monitoring and analysis procedures or test methods for applicable requirements of this Title V permit. In addition to the sampling, testing and monitoring procedures specified in this permit, the Permittee shall comply with any additional applicable requirements promulgated under the Clean Air Act after permit issuance regardless of whether the permit is revised.

(b) The sampling, testing and monitoring required under the applicable requirements of this permit, shall be conducted in accordance with the requirements of 25 Pa. Code Chapter 139 unless alternative methodology is required by the Clean Air Act (including §§ 114(a)(3) and 504(b)) and regulations adopted thereunder.

#024 [25 Pa. Code § 127.513]**Compliance Certification**

(a) One year after the date of issuance of the Title V permit, and each year thereafter, unless specified elsewhere in the permit, the permittee shall submit to the Department and EPA Region III a certificate of compliance with the terms and conditions in this permit, for the previous year, including the emission limitations, standards or work practices. This certification shall include:

- (1) The identification of each term or condition of the permit that is the basis of the certification.
- (2) The compliance status.
- (3) The methods used for determining the compliance status of the source, currently and over the reporting period.
- (4) Whether compliance was continuous or intermittent.

(b) The compliance certification shall be postmarked or hand-delivered no later than thirty days after each anniversary of

**SECTION B. General Title V Requirements**

the date of issuance of this Title V Operating Permit, or on the submittal date specified elsewhere in the permit, to the Department in accordance with the submission requirements specified in Section B, Condition #022 of this permit. The Title V compliance certification shall be emailed to EPA at R3_APD_Permits@epa.gov.

#025 [25 Pa. Code §§ 127.511 & Chapter 135]**Recordkeeping Requirements**

(a) The permittee shall maintain and make available, upon request by the Department, records of required monitoring information that include the following:

- (1) The date, place (as defined in the permit) and time of sampling or measurements.
- (2) The dates the analyses were performed.
- (3) The company or entity that performed the analyses.
- (4) The analytical techniques or methods used.
- (5) The results of the analyses.
- (6) The operating conditions as existing at the time of sampling or measurement.

(b) The permittee shall retain records of the required monitoring data and supporting information for at least five (5) years from the date of the monitoring sample, measurement, report or application. Supporting information includes the calibration data and maintenance records and original strip-chart recordings for continuous monitoring instrumentation, and copies of reports required by the permit.

(c) The permittee shall maintain and make available to the Department upon request, records including computerized records that may be necessary to comply with the reporting, recordkeeping and emission statement requirements in 25 Pa. Code Chapter 135 (relating to reporting of sources). In accordance with 25 Pa. Code Chapter 135, § 135.5, such records may include records of production, fuel usage, maintenance of production or pollution control equipment or other information determined by the Department to be necessary for identification and quantification of potential and actual air contaminant emissions. If direct recordkeeping is not possible or practical, sufficient records shall be kept to provide the needed information by indirect means.

#026 [25 Pa. Code §§ 127.411(d), 127.442, 127.463(e) & 127.511(c)]**Reporting Requirements**

(a) The permittee shall comply with the reporting requirements for the applicable requirements specified in this Title V permit. In addition to the reporting requirements specified herein, the permittee shall comply with any additional applicable reporting requirements promulgated under the Clean Air Act after permit issuance regardless of whether the permit is revised.

(b) Pursuant to 25 Pa. Code § 127.511(c), the permittee shall submit reports of required monitoring at least every six (6) months unless otherwise specified in this permit. Instances of deviations (as defined in 25 Pa. Code § 121.1) from permit requirements shall be clearly identified in the reports. The reporting of deviations shall include the probable cause of the deviations and corrective actions or preventative measures taken, except that sources with continuous emission monitoring systems shall report according to the protocol established and approved by the Department for the source. The required reports shall be certified by a responsible official.

(c) Every report submitted to the Department under this permit condition shall comply with the submission procedures specified in Section B, Condition #022(c) of this permit.

(d) Any records, reports or information obtained by the Department or referred to in a public hearing shall be made available to the public by the Department except for such records, reports or information for which the permittee has shown cause that the documents should be considered confidential and protected from disclosure to the public under Section 4013.2 of the Air Pollution Control Act and consistent with Sections 112(d) and 114(c) of the Clean Air Act and 25 Pa. Code § 127.411(d). The permittee may not request a claim of confidentiality for any emissions data generated for the Title V facility.

**SECTION B. General Title V Requirements****#027 [25 Pa. Code § 127.3]****Operational Flexibility**

The permittee is authorized to make changes within the Title V facility in accordance with the following provisions in 25 Pa. Code Chapter 127 which implement the operational flexibility requirements of Section 502(b)(10) of the Clean Air Act and Section 6.1(i) of the Air Pollution Control Act:

- (1) Section 127.14 (relating to exemptions)
- (2) Section 127.447 (relating to alternative operating scenarios)
- (3) Section 127.448 (relating to emissions trading at facilities with federally enforceable emissions caps)
- (4) Section 127.449 (relating to de minimis emission increases)
- (5) Section 127.450 (relating to administrative operating permit amendments)
- (6) Section 127.462 (relating to minor operating permit amendments)
- (7) Subchapter H (relating to general plan approvals and operating permits)

#028 [25 Pa. Code §§ 127.441(d), 127.512(i) and 40 CFR Part 68]**Risk Management**

(a) If required by Section 112(r) of the Clean Air Act, the permittee shall develop and implement an accidental release program consistent with requirements of the Clean Air Act, 40 CFR Part 68 (relating to chemical accident prevention provisions) and the Federal Chemical Safety Information, Site Security and Fuels Regulatory Relief Act (P.L. 106-40).

(b) The permittee shall prepare and implement a Risk Management Plan (RMP) which meets the requirements of Section 112(r) of the Clean Air Act, 40 CFR Part 68 and the Federal Chemical Safety Information, Site Security and Fuels Regulatory Relief Act when a regulated substance listed in 40 CFR § 68.130 is present in a process in more than the listed threshold quantity at the Title V facility. The permittee shall submit the RMP to the federal Environmental Protection Agency according to the following schedule and requirements:

- (1) The permittee shall submit the first RMP to a central point specified by EPA no later than the latest of the following:
 - (i) Three years after the date on which a regulated substance is first listed under § 68.130; or,
 - (ii) The date on which a regulated substance is first present above a threshold quantity in a process.

(2) The permittee shall submit any additional relevant information requested by the Department or EPA concerning the RMP and shall make subsequent submissions of RMPs in accordance with 40 CFR § 68.190.

(3) The permittee shall certify that the RMP is accurate and complete in accordance with the requirements of 40 CFR Part 68, including a checklist addressing the required elements of a complete RMP.

(c) As used in this permit condition, the term "process" shall be as defined in 40 CFR § 68.3. The term "process" means any activity involving a regulated substance including any use, storage, manufacturing, handling, or on-site movement of such substances or any combination of these activities. For purposes of this definition, any group of vessels that are interconnected, or separate vessels that are located such that a regulated substance could be involved in a potential release, shall be considered a single process.

(d) If the Title V facility is subject to 40 CFR Part 68, as part of the certification required under this permit, the permittee shall:

- (1) Submit a compliance schedule for satisfying the requirements of 40 CFR Part 68 by the date specified in 40 CFR § 68.10(a); or,
- (2) Certify that the Title V facility is in compliance with all requirements of 40 CFR Part 68 including the registration and submission of the RMP.

**SECTION B. General Title V Requirements**

(e) If the Title V facility is subject to 40 CFR Part 68, the permittee shall maintain records supporting the implementation of an accidental release program for five (5) years in accordance with 40 CFR § 68.200.

(f) When the Title V facility is subject to the accidental release program requirements of Section 112(r) of the Clean Air Act and 40 CFR Part 68, appropriate enforcement action will be taken by the Department if:

(1) The permittee fails to register and submit the RMP or a revised plan pursuant to 40 CFR Part 68.

(2) The permittee fails to submit a compliance schedule or include a statement in the compliance certification required under Section B, Condition #026 of this permit that the Title V facility is in compliance with the requirements of Section 112(r) of the Clean Air Act, 40 CFR Part 68, and 25 Pa. Code § 127.512(i).

#029 [25 Pa. Code § 127.512(e)]**Approved Economic Incentives and Emission Trading Programs**

No permit revision shall be required under approved economic incentives, marketable permits, emissions trading and other similar programs or processes for changes that are provided for in this Title V permit.

#030 [25 Pa. Code §§ 127.516, 127.450(d), 127.449(f) & 127.462(g)]**Permit Shield**

(a) The permittee's compliance with the conditions of this permit shall be deemed in compliance with applicable requirements (as defined in 25 Pa. Code § 121.1) as of the date of permit issuance if either of the following applies:

(1) The applicable requirements are included and are specifically identified in this permit.

(2) The Department specifically identifies in the permit other requirements that are not applicable to the permitted facility or source.

(b) Nothing in 25 Pa. Code § 127.516 or the Title V permit shall alter or affect the following:

(1) The provisions of Section 303 of the Clean Air Act, including the authority of the Administrator of the EPA provided thereunder.

(2) The liability of the permittee for a violation of an applicable requirement prior to the time of permit issuance.

(3) The applicable requirements of the acid rain program, consistent with Section 408(a) of the Clean Air Act.

(4) The ability of the EPA to obtain information from the permittee under Section 114 of the Clean Air Act.

(c) Unless precluded by the Clean Air Act or regulations thereunder, final action by the Department incorporating a significant permit modification in this Title V Permit shall be covered by the permit shield at the time that the permit containing the significant modification is issued.

#031 [25 Pa. Code §135.3]**Reporting**

(a) The permittee shall submit by March 1 of each year an annual emissions report for the preceding calendar year. The report shall include information for all active previously reported sources, new sources which were first operated during the preceding calendar year, and sources modified during the same period which were not previously reported. All air emissions from the facility should be estimated and reported.

(b) A source owner or operator may request an extension of time from the Department for the filing of an annual emissions report, and the Department may grant the extension for reasonable cause.

#032 [25 Pa. Code §135.4]**Report Format**

Emissions reports shall contain sufficient information to enable the Department to complete its emission inventory. Emissions reports shall be made by the source owner or operator in a format specified by the Department.

**SECTION C. Site Level Requirements****I. RESTRICTIONS.****Emission Restriction(s).****# 001 [25 Pa. Code §123.1]****Prohibition of certain fugitive emissions**

The permittee shall not allow the emission into the outdoor atmosphere of a fugitive air contaminant from a source other than the following:

- (a) Construction or demolition of buildings or structures.
- (b) Grading, paving, and maintenance of roads and streets.
- (c) Use of roads and streets. Emissions from material in or on trucks, railroad cars, and other vehicular equipment are not considered as emissions from use of roads and streets.
- (d) Clearing of land.
- (e) Stockpiling of materials.
- (f) Open burning of clearing and grubbing wastes (trees, shrubs and other native vegetation which are cleared from land during or prior to the process of construction; does not include demolition wastes and dirt-laden roots).
- (g) Sources and classes of sources other than those identified in (a)-(f), above, for which the permittee has obtained a determination from the Department, in accordance with 25 Pa. Code §123.1(b), that fugitive emissions from the source, after appropriate control, meet the following requirements:
 - (1) The emissions are of minor significance with respect to causing air pollution; and
 - (2) The emissions are not preventing or interfering with the attainment or maintenance of any ambient air quality standard.

002 [25 Pa. Code §123.2]**Fugitive particulate matter**

The permittee shall not allow the emission of fugitive particulate matter into the outdoor atmosphere from a source specified in Section C, Condition #001(a)-(g), if the emissions are visible at the point the emissions pass outside the permittee's property.

003 [25 Pa. Code §123.31]**Limitations**

The permittee shall not allow the emission into the outdoor atmosphere of any malodorous air contaminants from any source in such a manner that the malodors are detectable outside the permittee's property.

004 [25 Pa. Code §123.41]**Limitations**

The permittee shall not allow the emission into the outdoor atmosphere of visible air contaminants in such a manner that the opacity of the emission is either of the following:

- (a) Equal to or greater than 20% for a period or periods aggregating more than three minutes in any one hour.
- (b) Equal to or greater than 60% at any time.

[NOTE: THE GROUP 005 EMERGENCY QUENCH PUMPS ARE ALSO SUBJECT TO THE MORE STRINGENT VISIBLE EMISSIONS LIMIT OF CONDITION #001(b) OF SECTION E (GROUP 005)]

005 [25 Pa. Code §123.42]**Exceptions**

The emission limitations of Section C, Condition #004, shall not apply when:

- (a) The presence of uncombined water is the only reason for failure of the emission to meet the limitations.
- (b) The emission results from the operation of equipment used solely to train and test persons in observing the opacity of

**SECTION C. Site Level Requirements**

visible emissions.

(c) The emission results from sources specified in Section C, Condition #001(a)-(g).

006 [25 Pa. Code §127.512]**Operating permit terms and conditions.**

[Additional authority for this permit condition is also derived from Plan Approval No. 67-05005J]

The permittee shall limit the facility's annual NOx emissions to less than or equal to 14,254 tons during any consecutive 12-month period.

007 [25 Pa. Code §129.14]**Open burning operations**

(a) The permittee shall not allow the open burning of material on the permittee's property in a manner such that:

- (1) The emissions are visible, at any time, at the point such emissions pass outside the permittee's property.
- (2) Malodorous air contaminants from the open burning are detectable outside the permittee's property.
- (3) The emissions interfere with the reasonable enjoyment of life or property.
- (4) The emissions cause damage to vegetation or property.
- (5) The emissions are or may be deleterious to human or animal health.

(b) The requirements of (a), above, do not apply when the open burning operations result from:

- (1) A fire set to prevent or abate a fire hazard, when approved by the Department and set by or under the supervision of a public officer.
- (2) A fire set for the purpose of instructing personnel in fire fighting, when approved by the Department.
- (3) A fire set for the prevention and control of disease or pests, when approved by the Department.
- (4) A fire set solely for recreational or ceremonial purposes.
- (5) A fire set solely for cooking food.

(c) This permit condition does not constitute authorization to burn solid waste pursuant to Section 610(3) of the Solid Waste Management Act (SWMA), contained at 35 P.S. Section 6018.610(3), or any other provision of the SWMA.

II. TESTING REQUIREMENTS.**# 008 [25 Pa. Code §127.512]****Operating permit terms and conditions.**

The Department reserves the right to require exhaust stack testing of the sources referenced in this operating permit to measure emissions for purposes including verification of operating permit condition compliance and estimation of annual air emissions.

009 [25 Pa. Code §139.1]**Sampling facilities.**

Upon the request of the Department, the permittee shall provide adequate sampling ports, safe sampling platforms and adequate utilities for the performance by the Department of tests on any source. In the request, the Department will set forth the time period in which the facilities shall be provided as well as the specifications for such facilities.

**SECTION C. Site Level Requirements****# 010 [25 Pa. Code §139.11]****General requirements.**

(a) As specified in 25 Pa. Code §139.11(1), performance tests shall be conducted while the source is operating at maximum routine operating conditions or under such other conditions, within the capacity of the equipment, as may be requested by the Department.

(b) As specified in 25 Pa. Code §139.11(2), the Department will consider test results for approval where sufficient information is provided to verify the source conditions existing at the time of the test and where adequate data is available to show the manner in which the test was conducted. Information submitted to the Department shall include, at a minimum, all of the following:

- (1) A thorough source description, including a description of any air cleaning devices and the flue.
- (2) Process conditions, for example, the fuel firing rate, boiler pressure or temperature, electrostatic precipitator spark rate, and other conditions which may affect emissions from the process.
- (3) The location of the sampling ports.
- (4) Effluent characteristics, including velocity, temperature, moisture content, gas density (percentage CO, CO₂, O₂, and N₂), static and barometric pressures.
- (5) Sample collection techniques employed, including procedures used, equipment descriptions, and data to verify that isokinetic sampling for particulate matter collection occurred and that acceptable test conditions were met.
- (6) Laboratory procedures and results.
- (7) Calculated results.

III. MONITORING REQUIREMENTS.**# 011 [25 Pa. Code §123.43]****Measuring techniques**

The permittee shall measure visible emissions (referenced in Section C, Conditions #004, #005, and #012) using either of the following:

- (a) A device approved by the Department and maintained to provide accurate opacity measurements (e.g., Continuous Opacity Monitor).
- (b) Observers trained and certified in EPA Reference Method 9 to measure plume opacity with the naked eye; or with the aid of any device(s) approved by the Department.

012 [25 Pa. Code §127.511]**Monitoring and related recordkeeping and reporting requirements.**

The permittee shall conduct a daily inspection during regular business workdays (defined as Mondays through Fridays, except for national holidays) around the plant periphery during daylight hours when the plant is in production to detect visible emissions, fugitive particulate matter emissions, and malodorous air contaminants. Daily inspections are necessary to determine:

- (a) The presence of visible emissions as stated in Section C, Condition #004. Visible emissions may be measured according to the methods specified in Section C, Condition #011. Alternately, plant personnel who observe visible emissions may report the incidence of visible emissions to the Department within two (2) hours of the incident and make arrangements for a certified observer to measure the visible emissions.
- (b) The presence of fugitive particulate matter emissions beyond the plant property boundaries, as stated in Section C, Condition #002.

**SECTION C. Site Level Requirements**

(c) The presence of malodorous air contaminants beyond the plant property boundaries, as stated in Section C, Condition #003.

013 [25 Pa. Code §127.511]**Monitoring and related recordkeeping and reporting requirements.**

The permittee shall calculate the monthly air emissions from the facility using AP-42 emission factors, manufacturer-supplied emission factors, mass material balance, performance (stack) test data, CEMS data, or other method(s) acceptable to the Department.

IV. RECORDKEEPING REQUIREMENTS.**# 014 [25 Pa. Code §127.511]****Monitoring and related recordkeeping and reporting requirements.**

(a) The permittee shall maintain records of the daily inspections referenced in Section C, Condition #012. The records shall include, at a minimum, the following information:

- (1) The name of the company representative monitoring each inspection.
- (2) The date and time of each inspection.
- (3) The wind direction during each inspection.

(4) A description of the visible emissions, fugitive particulate matter emissions (beyond the plant property boundaries), and malodorous air contaminants (beyond the plant property boundaries) observed, if any, and actions taken to mitigate them. If no visible emissions or fugitive particulate matter emissions or malodors are observed, then document that none were observed.

(b) The permittee shall retain these records for a minimum of five (5) years. The records shall be made available to the Department upon its request.

015 [25 Pa. Code §127.511]**Monitoring and related recordkeeping and reporting requirements.**

(a) The permittee shall maintain records of the facility's monthly air emissions and calculations referenced in Section C, Condition #013.

(b) The permittee shall retain these records for a minimum of five (5) years. The records shall be made available to the Department upon its request.

016 [25 Pa. Code §127.511]**Monitoring and related recordkeeping and reporting requirements.**

(a) The permittee shall maintain records of the monthly usage of each fuel consumed at the entire facility.

(b) The permittee shall retain these records for a minimum of five (5) years. The records shall be made available to the Department upon its request.

017 [25 Pa. Code §127.511]**Monitoring and related recordkeeping and reporting requirements.**

[Additional authority for this permit condition is also derived from Plan Approval No. 67-05005J]

(a) The permittee shall calculate the monthly NO_x emissions from the facility using mass material balance, AP-42 emission factors, manufacturer-supplied emission factors, performance (stack) test data, CEMS data, or other method(s) acceptable to the Department. The permittee shall maintain records of the facility's monthly air emissions and calculations.

(b) The permittee shall calculate the cumulative facility air emissions for each consecutive 12-month period. The permittee shall maintain records of the cumulative facility air emissions for each consecutive 12-month period in order to demonstrate compliance with Section C, Condition #006, above.

**SECTION C. Site Level Requirements**

(c) The permittee shall retain these records for a minimum of five (5) years. The records shall be made available to the Department upon its request.

V. REPORTING REQUIREMENTS.**# 018 [25 Pa. Code §127.511]****Monitoring and related recordkeeping and reporting requirements.**

Pursuant to Section C, Condition #020(a), below, the permittee shall forward the annual certificate of compliance to U.S. EPA electronically, in lieu of a hard copy version, to the following email address: 'R3_APD_Permits@epa.gov'.

019 [25 Pa. Code §127.511]**Monitoring and related recordkeeping and reporting requirements.**

The permittee shall report malfunctions to the Department. A malfunction is any sudden, infrequent and not reasonably preventable failure of air pollution control or monitoring equipment, process equipment, or a process to operate in a normal or usual manner that may result in an increase in air emissions. Failures that are caused in part by poor maintenance or careless operation are not malfunctions. Malfunctions shall be reported as follows:

(a) Any malfunction which poses an imminent danger to the public health, safety, welfare, and environment, shall be immediately reported to the Department by telephone. The telephone report of such malfunctions shall occur no later than two (2) hours after the incident. The permittee shall submit a written report of instances of such malfunctions to the Department within three (3) days of the telephone report.

- (1) The notice shall describe the following:
- (i) name and location of the facility;
 - (ii) nature and cause of the malfunction;
 - (iii) time when the malfunction was first observed;
 - (iv) expected duration of excess emissions; and
 - (v) estimated rate of emissions.

(2) The permittee shall notify the Department immediately when corrective measures have been accomplished.

(b) Unless otherwise required by this operating permit, any other malfunction that is not subject to the reporting requirements of part (a), above, shall be reported to the Department, in writing, within five (5) days of malfunction discovery.

(c) Malfunctions shall be reported to the Department at the following address:

PA DEP
Southcentral Regional Office
Air Quality Program
909 Elmerton Avenue
Harrisburg, PA 17110-8200

Telephone reports shall be made to the Department's Air Quality Program at 717.705.4702 during normal business hours or to the Department's Emergency Hotline at any time. The Emergency Hotline phone number is changed/updated periodically. The current Emergency Hotline phone number can be found at:

<https://www.dep.pa.gov/About/Regional/SouthcentralRegion/Pages/default.aspx>

020 [25 Pa. Code §127.511]**Monitoring and related recordkeeping and reporting requirements.**

The permittee shall submit the following reports:

(a) An annual certificate of compliance, due by April 1st of each year, for the period covering January 1 through December 31 of the previous year. This certificate of compliance shall document compliance with all permit terms and conditions set forth in this Title V permit as required under Condition #26 of Section B of this Title V permit.

**SECTION C. Site Level Requirements**

(b) A semi-annual deviation report, due by October 1 of each year, for the period covering January 1 through June 30 of the same year. [NOTE: The annual certificate of compliance addressed in part (a), above, fulfills the obligation for the second semi-annual deviation reporting period (July 1 through December 31 of the previous year).]

021 [25 Pa. Code §135.3]**Reporting**

(a) An annual air emissions report for a given calendar year is due no later than March 1 of the following year, and shall be submitted via AES*Online, unless otherwise specified:

(b) The monthly fuel usage referenced in Section C, Condition #016, shall be included in the annual air emissions report.

(c) The monthly air emissions and calculations referenced in Section C, Conditions #013 and #015, shall be included in the annual air emissions report.

(d) The permittee may request an extension of time from the Department for the filing of the air emissions report specified in part (a), above, and the Department may grant the extension for reasonable cause.

(e) The annual emission statement shall contain a certification by a company officer or the plant manager that the information contained in the statement is accurate.

VI. WORK PRACTICE REQUIREMENTS.**# 022 [25 Pa. Code §123.1]****Prohibition of certain fugitive emissions**

The permittee shall take all reasonable actions to prevent particulate matter from becoming airborne from any source specified in Section C, Condition #001(a)-(g). These actions shall include, but are not limited to, the following:

(a) Use, where possible, of water or chemicals for control of dust in the demolition of buildings or structures, construction operations, the grading of roads, or the clearing of land.

(b) Application of asphalt, oil, water, or suitable chemicals on dirt roads, material stockpiles and other surfaces which may give rise to airborne dusts.

(c) Paving and maintenance of roadways.

(d) Prompt removal of earth or other material from paved streets onto which earth or other material has been transported by trucking or earth moving equipment, erosion by water, or other means.

023 [25 Pa. Code §127.444]**Compliance requirements.**

The permittee shall operate and maintain all sources and any air cleaning devices identified in this operating permit in accordance with the manufacturer's recommendations/specifications, as well as in a manner consistent with good operating and air pollution control practices that minimize air emissions.

VII. ADDITIONAL REQUIREMENTS.

No additional requirements exist except as provided in other sections of this permit including Section B (Title V General Requirements).

VIII. COMPLIANCE CERTIFICATION.

No additional compliance certifications exist except as provided in other sections of this permit including Section B (relating to Title V General Requirements).

IX. COMPLIANCE SCHEDULE.

No compliance milestones exist.

***** Permit Shield In Effect *****

**SECTION D. Source Level Requirements**

Source ID: 031A

Source Name: BRUNNER ISLAND UNIT 1

Source Capacity/Throughput: 3,345.000 MMBTU/HR

134.000 Tons/HR

Bituminous

4,960.000 Gal/HR

#2 Oil

3,345.000 MCF/HR

Natural Gas

Conditions for this source occur in the following groups: GROUP 001
 GROUP 004
 GROUP 007
 GROUP 008
 GROUP 009
 GROUP 011
 GROUP 012
 GROUP 014

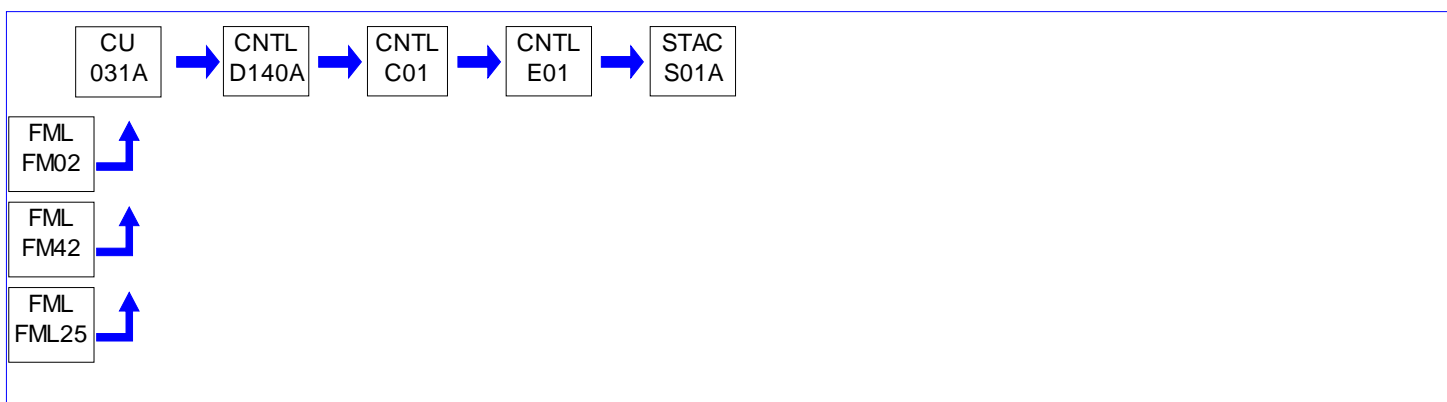
**I. RESTRICTIONS.****Emission Restriction(s).****# 001 [25 Pa. Code §127.512]****Operating permit terms and conditions.**

[Additional authority for this permit condition is also derived from Plan Approval No. 67-05005J]

The permittee shall limit Source ID 031A's annual NO_x emissions to less than or equal to 3,751 tons during any consecutive 12-month period.

II. TESTING REQUIREMENTS.

No additional testing requirements exist except as provided in other sections of this permit including Section B (Title V General Requirements) and/or Section E (Source Group Restrictions).

III. MONITORING REQUIREMENTS.

No additional monitoring requirements exist except as provided in other sections of this permit including Section B (Title V General Requirements) and/or Section E (Source Group Restrictions).

IV. RECORDKEEPING REQUIREMENTS.**# 002 [25 Pa. Code §127.511]****Monitoring and related recordkeeping and reporting requirements.**

[Additional authority for this permit condition is also derived from Plan Approval No. 67-05005J]

(a) The permittee shall calculate the monthly NO_x emissions from Source ID 031A using CEMS data, mass material

**SECTION D. Source Level Requirements**

balance, AP-42 emission factors, manufacturer-supplied emission factors, performance (stack) test data, or other method(s) acceptable to the Department. The permittee shall maintain records of the facility's monthly air emissions and calculations.

(b) The permittee shall calculate the cumulative Source ID 031A NOx emissions for each consecutive 12-month period. The permittee shall maintain records of the cumulative Source ID 031A NOx emissions for each consecutive 12-month period in order to demonstrate compliance with Condition #001, above.

(c) The permittee shall retain these records for a minimum of five (5) years. The records shall be made available to the Department upon its request.

V. REPORTING REQUIREMENTS.

No additional reporting requirements exist except as provided in other sections of this permit including Section B (Title V General Requirements) and/or Section E (Source Group Restrictions).

VI. WORK PRACTICE REQUIREMENTS.

003 [25 Pa. Code §127.512]

Operating permit terms and conditions.

(a) The permittee shall operate the Source ID C01 fabric collector and the Source ID E01 FGD scrubber at all times that Source ID 031A is operating, except as provided in part (b), below.

(b) The permittee may elect to not operate the Source ID C01 fabric collector during Source ID 031A natural gas-firing operating scenarios, so long as such operation is not contrary to 40 CFR Part 63, Subpart UUUUU (MACT Subpart UUUUU).

VII. ADDITIONAL REQUIREMENTS.

No additional requirements exist except as provided in other sections of this permit including Section B (Title V General Requirements) and/or Section E (Source Group Restrictions).

***** Permit Shield in Effect. *****

**SECTION D. Source Level Requirements**

Source ID: 032

Source Name: BRUNNER ISLAND UNIT 2

Source Capacity/Throughput: 3,800.000 MMBTU/HR

5,760.000 Gal/HR

#2 Oil

3,800.000 MCF/HR

Natural Gas

152.000 Tons/HR

Bituminous

Conditions for this source occur in the following groups: GROUP 001
 GROUP 004
 GROUP 007
 GROUP 008
 GROUP 009
 GROUP 011
 GROUP 012
 GROUP 014

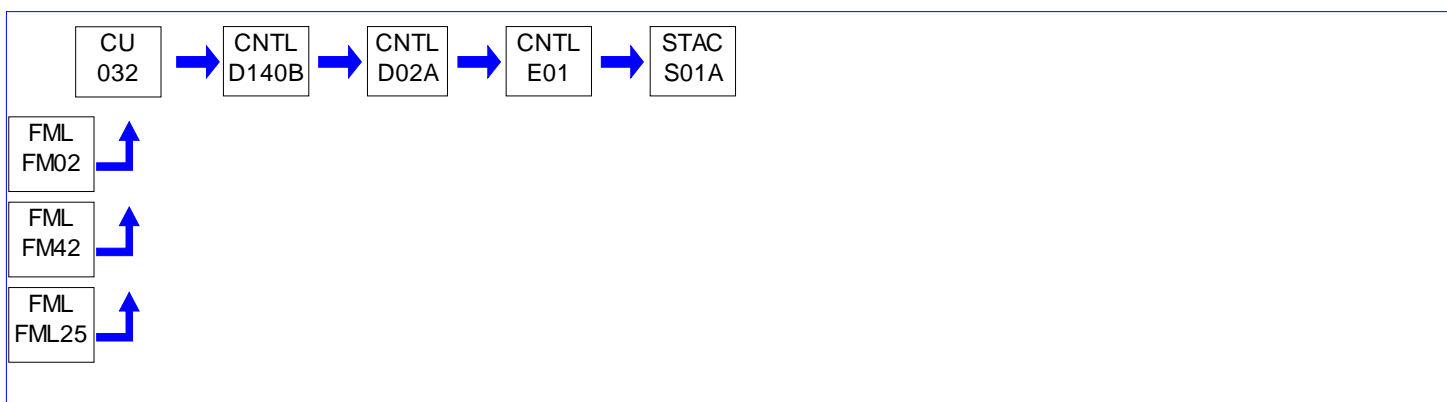
**I. RESTRICTIONS.****Emission Restriction(s).****# 001 [25 Pa. Code §127.512]****Operating permit terms and conditions.**

[Additional authority for this permit condition is also derived from Plan Approval No. 67-05005J]

The permittee shall limit Source ID 032's annual NOx emissions to less than or equal to 4,261 tons during any consecutive 12-month period.

II. TESTING REQUIREMENTS.

No additional testing requirements exist except as provided in other sections of this permit including Section B (Title V General Requirements) and/or Section E (Source Group Restrictions).

III. MONITORING REQUIREMENTS.

No additional monitoring requirements exist except as provided in other sections of this permit including Section B (Title V General Requirements) and/or Section E (Source Group Restrictions).

IV. RECORDKEEPING REQUIREMENTS.**# 002 [25 Pa. Code §127.511]****Monitoring and related recordkeeping and reporting requirements.**

[Additional authority for this permit condition is also derived from Plan Approval No. 67-05005J]

(a) The permittee shall calculate the monthly NOx emissions from Source ID 032 using CEMS data, mass material balance,

**SECTION D. Source Level Requirements**

AP-42 emission factors, manufacturer-supplied emission factors, performance (stack) test data, or other method(s) acceptable to the Department. The permittee shall maintain records of the facility's monthly air emissions and calculations.

(b) The permittee shall calculate the cumulative Source ID 032 NOx emissions for each consecutive 12-month period. The permittee shall maintain records of the cumulative Source ID 032 NOx emissions for each consecutive 12-month period in order to demonstrate compliance with Condition #001, above.

(c) The permittee shall retain these records for a minimum of five (5) years. The records shall be made available to the Department upon its request.

V. REPORTING REQUIREMENTS.

No additional reporting requirements exist except as provided in other sections of this permit including Section B (Title V General Requirements) and/or Section E (Source Group Restrictions).

VI. WORK PRACTICE REQUIREMENTS.

003 [25 Pa. Code §127.512]

Operating permit terms and conditions.

Unless otherwise approved in writing by the Department, the permittee shall operate and maintain Source ID 032's ESP in accordance with the operation & maintenance (O&M) plan that was received and approved by the Department on February 5, 2010.

004 [25 Pa. Code §127.512]

Operating permit terms and conditions.

(a) The permittee shall operate the Source ID D02A ESP and the Source ID E01 FGD scrubber at all times that Source ID 032 is operating, except as provided in part (b), below.

(b) The permittee may elect to not operate the Source ID D02A ESP during Source ID 032 natural gas-firing operating scenarios, so long as such operation is not contrary to 40 CFR Part 63, Subpart UUUUU (MACT Subpart UUUUU).

VII. ADDITIONAL REQUIREMENTS.

No additional requirements exist except as provided in other sections of this permit including Section B (Title V General Requirements) and/or Section E (Source Group Restrictions).

***** Permit Shield in Effect. *****

**SECTION D. Source Level Requirements**

Source ID: 033A

Source Name: BRUNNER ISLAND UNIT 3

Source Capacity/Throughput: 7,329.000 MMBTU/HR

289.600 Tons/HR

Bituminous

8,600.000 Gal/HR

#2 Oil

7,329.000 MCF/HR

Natural Gas

Conditions for this source occur in the following groups: GROUP 001
 GROUP 004
 GROUP 007
 GROUP 008
 GROUP 009
 GROUP 011
 GROUP 012
 GROUP 014

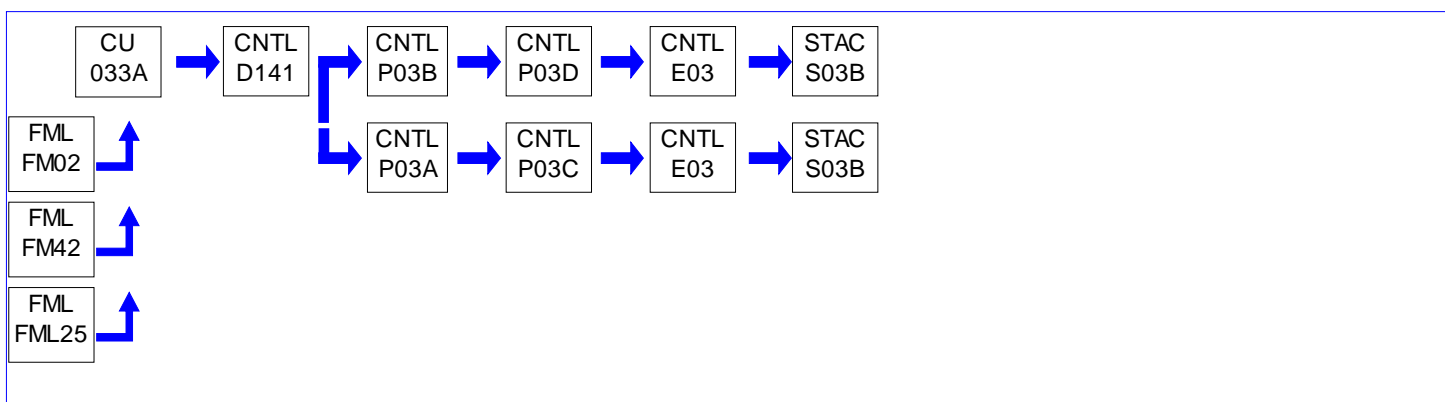
**I. RESTRICTIONS.****Emission Restriction(s).**

001 [25 Pa. Code §127.512]

Operating permit terms and conditions.

[Additional authority for this permit condition is also derived from Plan Approval No. 67-05005J]

The permittee shall limit Source ID 033A's annual NOx emissions to less than or equal to 8,186 tons during any consecutive 12-month period.

II. TESTING REQUIREMENTS.

No additional testing requirements exist except as provided in other sections of this permit including Section B (Title V General Requirements) and/or Section E (Source Group Restrictions).

III. MONITORING REQUIREMENTS.

No additional monitoring requirements exist except as provided in other sections of this permit including Section B (Title V General Requirements) and/or Section E (Source Group Restrictions).

IV. RECORDKEEPING REQUIREMENTS.

002 [25 Pa. Code §127.511]

Monitoring and related recordkeeping and reporting requirements.

[Additional authority for this permit condition is also derived from Plan Approval No. 67-05005J]

(a) The permittee shall calculate the monthly NOx emissions from Source ID 033A using CEMS data, mass material

**SECTION D. Source Level Requirements**

balance, AP-42 emission factors, manufacturer-supplied emission factors, performance (stack) test data, or other method(s) acceptable to the Department. The permittee shall maintain records of the facility's monthly air emissions and calculations.

(b) The permittee shall calculate the cumulative Source ID 033A NOx emissions for each consecutive 12-month period. The permittee shall maintain records of the cumulative Source ID 033A NOx emissions for each consecutive 12-month period in order to demonstrate compliance with Condition #001, above.

(c) The permittee shall retain these records for a minimum of five (5) years. The records shall be made available to the Department upon its request.

V. REPORTING REQUIREMENTS.

No additional reporting requirements exist except as provided in other sections of this permit including Section B (Title V General Requirements) and/or Section E (Source Group Restrictions).

VI. WORK PRACTICE REQUIREMENTS.**# 003 [25 Pa. Code §127.512]****Operating permit terms and conditions.**

Unless otherwise approved in writing by the Department, the permittee shall operate and maintain Source ID 033A's ESPs in accordance with the operation and maintenance (O&M) plan that was received and approved by the Department on July 5, 2007.

004 [25 Pa. Code §127.512]**Operating permit terms and conditions.**

(a) The permittee shall operate the Source ID P03A, P03B, P03C, and P03D ESPs and the Source ID E03 FGD scrubber at all times that Source ID 033A is operating, except as provided in part (b), below.

(b) The permittee may elect to not operate the Source ID P03A, P03B, P03C, and P03D ESPs during Source ID 033A natural gas-firing operating scenarios, so long as such operation is not contrary to 40 CFR Part 63, Subpart UUUUU (MACT Subpart UUUUU).

VII. ADDITIONAL REQUIREMENTS.

No additional requirements exist except as provided in other sections of this permit including Section B (Title V General Requirements) and/or Section E (Source Group Restrictions).

***** Permit Shield in Effect. *****

**SECTION D. Source Level Requirements**

Source ID: 034

Source Name: G-M DIESEL GENERATOR 1

Source Capacity/Throughput: 26.200 MMBTU/HR

I. RESTRICTIONS.

No additional requirements exist except as provided in other sections of this permit including Section B (Title V General Requirements).

II. TESTING REQUIREMENTS.

No additional testing requirements exist except as provided in other sections of this permit including Section B (Title V General Requirements).

III. MONITORING REQUIREMENTS.

No additional monitoring requirements exist except as provided in other sections of this permit including Section B (Title V General Requirements).

IV. RECORDKEEPING REQUIREMENTS.

No additional record keeping requirements exist except as provided in other sections of this permit including Section B (Title V General Requirements).

V. REPORTING REQUIREMENTS.

No additional reporting requirements exist except as provided in other sections of this permit including Section B (Title V General Requirements).

VI. WORK PRACTICE REQUIREMENTS.

No additional work practice requirements exist except as provided in other sections of this permit including Section B (Title V General Requirements).

VII. ADDITIONAL REQUIREMENTS.

No additional requirements exist except as provided in other sections of this permit including Section B (Title V General Requirements).

***** Permit Shield in Effect. *****



SECTION D. Source Level Requirements

Source ID: 037

Source Name: DIESEL- FIRED QUENCH PUMP 1

Source Capacity/Throughput: 4.027 MMBTU/HR

30.000 Gal/HR

Diesel Fuel

Conditions for this source occur in the following groups: GROUP 005
GROUP 010

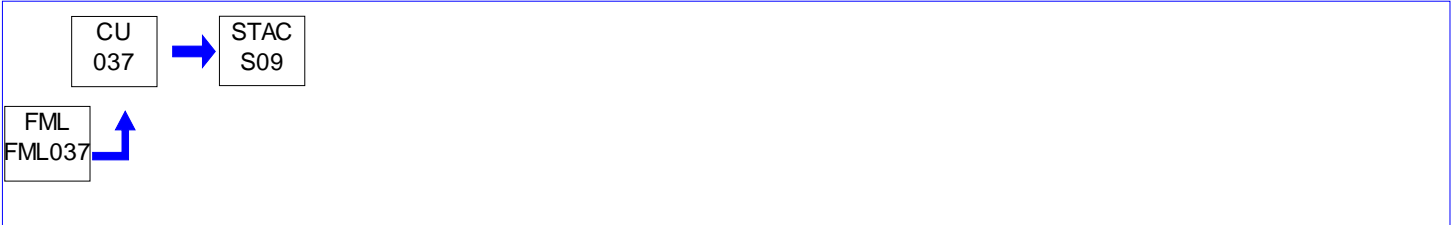

I. RESTRICTIONS.

No additional requirements exist except as provided in other sections of this permit including Section B (Title V General Requirements) and/or Section E (Source Group Restrictions).

II. TESTING REQUIREMENTS.

No additional testing requirements exist except as provided in other sections of this permit including Section B (Title V General Requirements) and/or Section E (Source Group Restrictions).

III. MONITORING REQUIREMENTS.

No additional monitoring requirements exist except as provided in other sections of this permit including Section B (Title V General Requirements) and/or Section E (Source Group Restrictions).

IV. RECORDKEEPING REQUIREMENTS.

No additional record keeping requirements exist except as provided in other sections of this permit including Section B (Title V General Requirements) and/or Section E (Source Group Restrictions).

V. REPORTING REQUIREMENTS.

No additional reporting requirements exist except as provided in other sections of this permit including Section B (Title V General Requirements) and/or Section E (Source Group Restrictions).

VI. WORK PRACTICE REQUIREMENTS.

No additional work practice requirements exist except as provided in other sections of this permit including Section B (Title V General Requirements) and/or Section E (Source Group Restrictions).

VII. ADDITIONAL REQUIREMENTS.

No additional requirements exist except as provided in other sections of this permit including Section B (Title V General Requirements) and/or Section E (Source Group Restrictions).

***** Permit Shield in Effect. *****

**SECTION D. Source Level Requirements**

Source ID: 038

Source Name: DIESEL- FIRED QUENCH PUMP 2

Source Capacity/Throughput: 4.027 MMBTU/HR

30.000 Gal/HR

Diesel Fuel

Conditions for this source occur in the following groups: GROUP 005
GROUP 010

**I. RESTRICTIONS.**

No additional requirements exist except as provided in other sections of this permit including Section B (Title V General Requirements) and/or Section E (Source Group Restrictions).

II. TESTING REQUIREMENTS.

No additional testing requirements exist except as provided in other sections of this permit including Section B (Title V General Requirements) and/or Section E (Source Group Restrictions).

III. MONITORING REQUIREMENTS.

No additional monitoring requirements exist except as provided in other sections of this permit including Section B (Title V General Requirements) and/or Section E (Source Group Restrictions).

IV. RECORDKEEPING REQUIREMENTS.

No additional record keeping requirements exist except as provided in other sections of this permit including Section B (Title V General Requirements) and/or Section E (Source Group Restrictions).

V. REPORTING REQUIREMENTS.

No additional reporting requirements exist except as provided in other sections of this permit including Section B (Title V General Requirements) and/or Section E (Source Group Restrictions).

VI. WORK PRACTICE REQUIREMENTS.

No additional work practice requirements exist except as provided in other sections of this permit including Section B (Title V General Requirements) and/or Section E (Source Group Restrictions).

VII. ADDITIONAL REQUIREMENTS.

No additional requirements exist except as provided in other sections of this permit including Section B (Title V General Requirements) and/or Section E (Source Group Restrictions).

***** Permit Shield in Effect. *****

**SECTION D. Source Level Requirements**

Source ID: 050

Source Name: FOUR NG-FIRED NG PIPELINE HEATERS

Source Capacity/Throughput: 30.400 MMBTU/HR
30.400 MCF/HR NATURAL GAS (TOTAL)

Conditions for this source occur in the following groups: GROUP 014
GROUP 016

**I. RESTRICTIONS.****Emission Restriction(s).****# 001 [25 Pa. Code §123.11]****Combustion units**

[Additional authority for this permit condition is also derived from Plan Approval No. 67-05005H]

The permittee shall not allow the emission of filterable particulate matter (FPM) into the outdoor atmosphere from each Source ID 050 heater in excess of 0.4 pound per million BTU of heat input.

002 [25 Pa. Code §123.22]**Combustion units**

[Additional authority for this permit condition is also derived from Plan Approval No. 67-05005H]

The permittee shall not allow the emission into the outdoor atmosphere of sulfur oxides, expressed as SO₂, from each Source ID 050 heater in excess of four (4) pounds per million BTU of heat input over any one (1) hour period.

[NOTE: Compliance with the requirement(s) specified in this streamlined permit condition assures compliance with the SIP-approved sulfur dioxide emission limit specified in 40 CFR §52.2020(c)(1)]

Fuel Restriction(s).**# 003 [25 Pa. Code §127.512]****Operating permit terms and conditions.**

[Additional authority for this permit condition is also derived from Plan Approval No. 67-05005H]

The permittee shall operate each Source ID 050 heater using natural gas fuel only.

II. TESTING REQUIREMENTS.

No additional testing requirements exist except as provided in other sections of this permit including Section B (Title V General Requirements) and/or Section E (Source Group Restrictions).

III. MONITORING REQUIREMENTS.

No additional monitoring requirements exist except as provided in other sections of this permit including Section B (Title V General Requirements) and/or Section E (Source Group Restrictions).



SECTION D. Source Level Requirements

IV. RECORDKEEPING REQUIREMENTS.

No additional record keeping requirements exist except as provided in other sections of this permit including Section B (Title V General Requirements) and/or Section E (Source Group Restrictions).

V. REPORTING REQUIREMENTS.

No additional reporting requirements exist except as provided in other sections of this permit including Section B (Title V General Requirements) and/or Section E (Source Group Restrictions).

VI. WORK PRACTICE REQUIREMENTS.

No additional work practice requirements exist except as provided in other sections of this permit including Section B (Title V General Requirements) and/or Section E (Source Group Restrictions).

VII. ADDITIONAL REQUIREMENTS.

No additional requirements exist except as provided in other sections of this permit including Section B (Title V General Requirements) and/or Section E (Source Group Restrictions).

***** Permit Shield in Effect. *****

**SECTION D. Source Level Requirements**

Source ID: 101

Source Name: ROADWAYS

Source Capacity/Throughput:

I. RESTRICTIONS.

No additional requirements exist except as provided in other sections of this permit including Section B (Title V General Requirements).

II. TESTING REQUIREMENTS.

No additional testing requirements exist except as provided in other sections of this permit including Section B (Title V General Requirements).

III. MONITORING REQUIREMENTS.

No additional monitoring requirements exist except as provided in other sections of this permit including Section B (Title V General Requirements).

IV. RECORDKEEPING REQUIREMENTS.

No additional record keeping requirements exist except as provided in other sections of this permit including Section B (Title V General Requirements).

V. REPORTING REQUIREMENTS.

No additional reporting requirements exist except as provided in other sections of this permit including Section B (Title V General Requirements).

VI. WORK PRACTICE REQUIREMENTS.

No additional work practice requirements exist except as provided in other sections of this permit including Section B (Title V General Requirements).

VII. ADDITIONAL REQUIREMENTS.

No additional requirements exist except as provided in other sections of this permit including Section B (Title V General Requirements).

***** Permit Shield in Effect. *****

**SECTION D. Source Level Requirements**

Source ID: 110

Source Name: RAILCAR UNLOADING OPERATION

Source Capacity/Throughput: 1,600.000 Tons/HR COAL

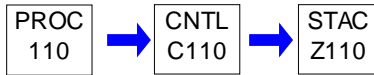
**I. RESTRICTIONS.**

No additional requirements exist except as provided in other sections of this permit including Section B (Title V General Requirements).

II. TESTING REQUIREMENTS.

No additional testing requirements exist except as provided in other sections of this permit including Section B (Title V General Requirements).

III. MONITORING REQUIREMENTS.

No additional monitoring requirements exist except as provided in other sections of this permit including Section B (Title V General Requirements).

IV. RECORDKEEPING REQUIREMENTS.

No additional record keeping requirements exist except as provided in other sections of this permit including Section B (Title V General Requirements).

V. REPORTING REQUIREMENTS.

No additional reporting requirements exist except as provided in other sections of this permit including Section B (Title V General Requirements).

VI. WORK PRACTICE REQUIREMENTS.**# 001 [25 Pa. Code §127.512]****Operating permit terms and conditions.**

[Additional authority for this permit condition is also derived from 25 Pa. Code §§123.1 and 127.1, and Plan Approval No. 67-05005B]

(a) The permittee shall take all reasonable actions to prevent particulate matter from becoming airborne. These actions, at a minimum, shall include the following:

(1) Water sprays shall be installed, operated and maintained for the control of visible fugitive emissions from the unloading of coal from the rotary car dumper.

(2) The water sprays shall be activated during the unloading of the coal and remain activated for a period of time as necessary to adequately control the formation of airborne particulate matter.

(b) The Department reserves the right to require additional controls or modifications to existing controls if at any time it is determined that the existing controls are inadequate in controlling fugitive particulate matter.

**SECTION D. Source Level Requirements****VII. ADDITIONAL REQUIREMENTS.**

No additional requirements exist except as provided in other sections of this permit including Section B (Title V General Requirements).

***** Permit Shield in Effect. *****

**SECTION D. Source Level Requirements**

Source ID: 127

Source Name: DRY ASH HANDLING SYSTEM

Source Capacity/Throughput: 132.000 Tons/HR DRY ASH HANDLED

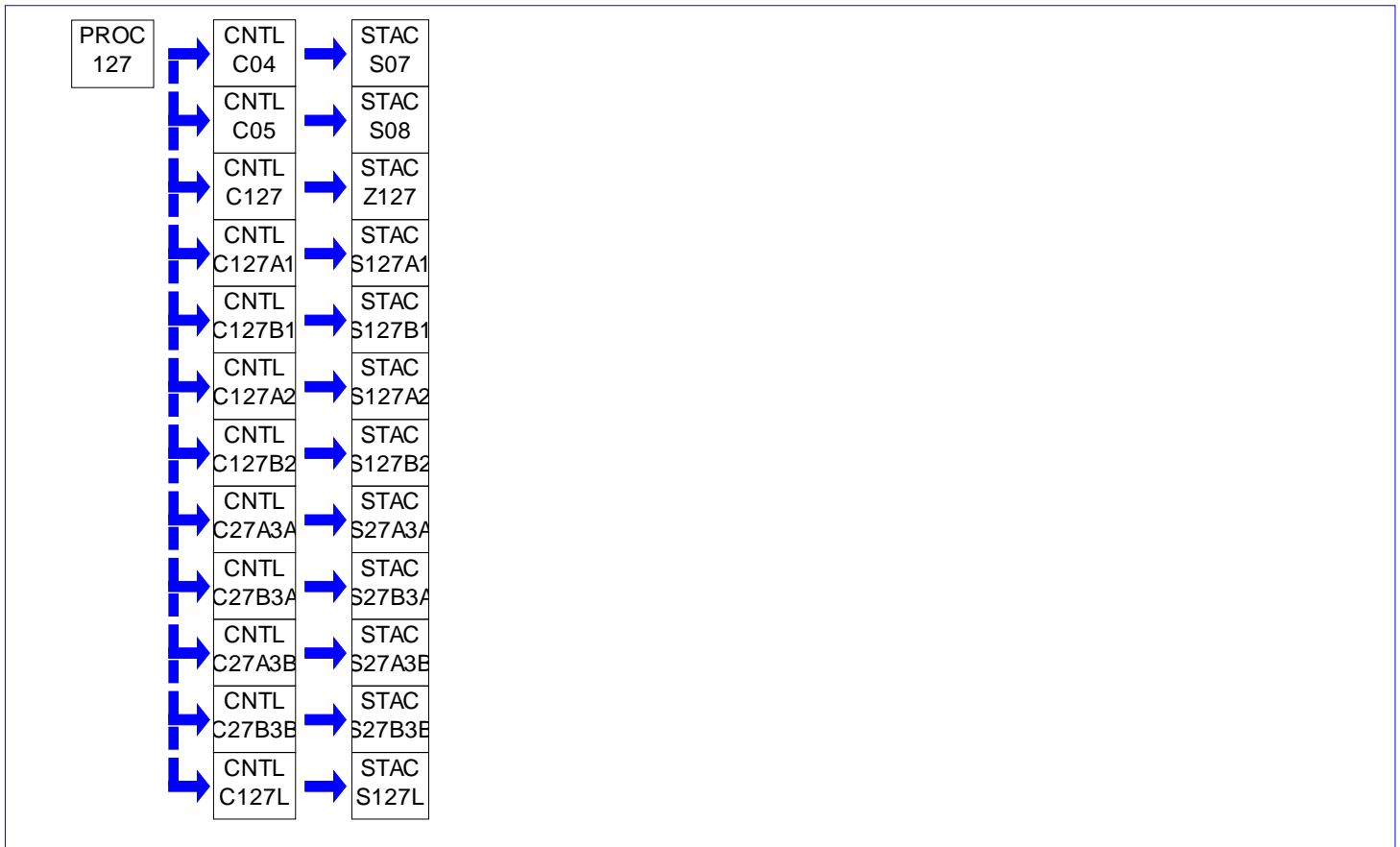
**I. RESTRICTIONS.****Emission Restriction(s).****# 001 [25 Pa. Code §123.13]****Processes**

(a) Pursuant to 25 Pa. Code §123.13(c)(1)(i), filterable particulate matter (FPM) emissions from each Source ID 127 control device's exhaust shall not exceed 0.04 grain per dry standard cubic foot.

(b) The PM emission rate limitation of part (a), above, only applies to those Source ID 127 control devices having a flue. Flue, as defined in 25 Pa. Code §121.1, means a duct, pipe, stack, chimney or conduit permitting air contaminants to be emitted into the outdoor atmosphere which is of a nature so as to permit the performance of the test methods and procedures specified in Chapter 139 (relating to sampling and testing).

II. TESTING REQUIREMENTS.

No additional testing requirements exist except as provided in other sections of this permit including Section B (Title V General Requirements).

III. MONITORING REQUIREMENTS.

No additional monitoring requirements exist except as provided in other sections of this permit including Section B (Title V General Requirements).

**SECTION D. Source Level Requirements****IV. RECORDKEEPING REQUIREMENTS.****# 002 [25 Pa. Code §127.511]****Monitoring and related recordkeeping and reporting requirements.**

(a) The permittee shall maintain detailed records of all maintenance performed on each Source ID 127 bin vent collector and fabric collector.

(b) The permittee shall retain these records for a minimum of five (5) years and shall make them available to the Department upon its request.

V. REPORTING REQUIREMENTS.

No additional reporting requirements exist except as provided in other sections of this permit including Section B (Title V General Requirements).

VI. WORK PRACTICE REQUIREMENTS.**# 003 [25 Pa. Code §127.512]****Operating permit terms and conditions.**

The permittee shall operate each Source ID 127 bin vent collector and fabric collector, as applicable, at all times that Source ID 127 is operating.

004 [25 Pa. Code §127.512]**Operating permit terms and conditions.**

The permittee shall operate and maintain each Source ID 127 bin vent collector and fabric collector in accordance with the manufacturer's specifications.

VII. ADDITIONAL REQUIREMENTS.

No additional requirements exist except as provided in other sections of this permit including Section B (Title V General Requirements).

***** Permit Shield in Effect. *****

**SECTION D. Source Level Requirements**

Source ID: 131

Source Name: LIMESTONE MATERIAL HANDLING OPERATIONS

Source Capacity/Throughput: 2,000.000 Tons/HR LIMESTONE

Conditions for this source occur in the following groups: GROUP 006

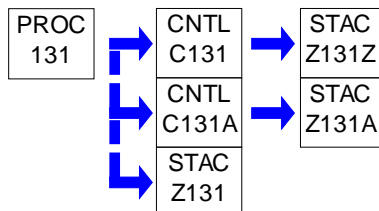
**I. RESTRICTIONS.**

No additional requirements exist except as provided in other sections of this permit including Section B (Title V General Requirements) and/or Section E (Source Group Restrictions).

II. TESTING REQUIREMENTS.

No additional testing requirements exist except as provided in other sections of this permit including Section B (Title V General Requirements) and/or Section E (Source Group Restrictions).

III. MONITORING REQUIREMENTS.

No additional monitoring requirements exist except as provided in other sections of this permit including Section B (Title V General Requirements) and/or Section E (Source Group Restrictions).

IV. RECORDKEEPING REQUIREMENTS.**# 001 [25 Pa. Code §127.511]****Monitoring and related recordkeeping and reporting requirements.**

[Additional authority for this permit condition is also derived from Plan Approval No. 67-05005E]

(a) In order to quantify emissions of PM and PM10 from the operations associated with Source ID 131, the permittee shall maintain accurate and comprehensive records of the following information:

- (1) The total amount of limestone delivered by railcar each month.
- (2) The total amount of limestone delivered by truck each month.

(b) All records shall be maintained at the facility for a minimum of five (5) years and shall be made available to the Department upon its request.

V. REPORTING REQUIREMENTS.

No additional reporting requirements exist except as provided in other sections of this permit including Section B (Title V General Requirements) and/or Section E (Source Group Restrictions).

VI. WORK PRACTICE REQUIREMENTS.**# 002 [25 Pa. Code §127.512]****Operating permit terms and conditions.**

[Additional authority for this permit condition is also derived from 25 Pa. Code §127.1 and Plan Approval No. 67-05005E]

**SECTION D. Source Level Requirements**

The air contaminant emissions from Source ID 131 shall be controlled by two Dust Solutions, Inc., dry fog dust suppression systems (Source IDs C131 & C131A), one controlling emissions from the railcar limestone unloading system (Source ID C131) and the other controlling emissions from the limestone reclaim system (Source ID C131A).

003 [25 Pa. Code §127.512]**Operating permit terms and conditions.**

[Additional authority for this permit condition is also derived from 25 Pa. Code §127.1 and Plan Approval No. 67-05005E]

The dry fog dust suppression system associated with Source ID 131 shall be equipped with a winterization system to allow for operation during cold weather conditions and be equipped with filters or strainers to remove any particles that may clog the system's spray nozzles.

004 [25 Pa. Code §127.512]**Operating permit terms and conditions.**

[Additional authority for this permit condition is also derived from 25 Pa. Code §127.1 and Plan Approval No. 67-05005E]

(a) Each of the dry fog dust suppression systems associated with Source ID 131 shall be connected to and operated with an adequate supply of water at all times that its respective controlled components are in operation.

(b) If at any time the dry fog suppression system for the limestone railcar unloading or limestone reclaim system is inoperable, or is not being supplied with an adequate amount of water, the permittee shall immediately cease operations of those components associated with the malfunctioning control system.

005 [25 Pa. Code §127.512]**Operating permit terms and conditions.**

[Additional authority for this permit condition is also derived from 25 Pa. Code §127.1 and Plan Approval No. 67-05005E]

All railcars delivering limestone shall be unloaded inside of the enclosure and shall be unloaded through the bottom of the railcars into the track level hopper.

006 [25 Pa. Code §127.512]**Operating permit terms and conditions.**

[Additional authority for this permit condition is also derived from 25 Pa. Code §127.1 and Plan Approval No. 67-05005E]

Limestone shall be reclaimed from the active limestone storage pile only by use of the underground reclaim system associated with the respective storage pile.

007 [25 Pa. Code §127.512]**Operating permit terms and conditions.**

[Additional authority for this permit condition is also derived from 25 Pa. Code §127.1 and Plan Approval No. 67-05005E]

The vents from the limestone storage silos shall be equipped with bin vent filters that exhaust to the indoors. All means of access to the limestone preparation building such as windows, doors, etc., shall be kept closed during those times when the conveyors and silos are in operation.

VII. ADDITIONAL REQUIREMENTS.

No additional requirements exist except as provided in other sections of this permit including Section B (Title V General Requirements) and/or Section E (Source Group Restrictions).

***** Permit Shield in Effect. *****

**SECTION D. Source Level Requirements**

Source ID: 132

Source Name: GYPSUM MATERIAL HANDLING OPERATIONS

Source Capacity/Throughput: 270.000 Tons/HR SYNTHETIC GYPSUM

Conditions for this source occur in the following groups: GROUP 006

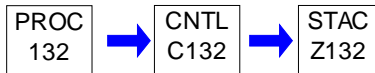
**I. RESTRICTIONS.**

No additional requirements exist except as provided in other sections of this permit including Section B (Title V General Requirements) and/or Section E (Source Group Restrictions).

II. TESTING REQUIREMENTS.

No additional testing requirements exist except as provided in other sections of this permit including Section B (Title V General Requirements) and/or Section E (Source Group Restrictions).

III. MONITORING REQUIREMENTS.

No additional monitoring requirements exist except as provided in other sections of this permit including Section B (Title V General Requirements) and/or Section E (Source Group Restrictions).

IV. RECORDKEEPING REQUIREMENTS.**# 001 [25 Pa. Code §127.512]****Operating permit terms and conditions.**

[Additional authority for this permit condition is also derived from Plan Approval No. 67-05005E]

(a) In order to quantify the emissions of PM and PM10 from Source ID 132, the permittee shall maintain accurate and comprehensive records of the amount of gypsum sludge handled or processed on a monthly basis.

(b) The records shall be maintained at the facility for a period of five (5) years and shall be made available to the Department upon its request.

V. REPORTING REQUIREMENTS.

No additional reporting requirements exist except as provided in other sections of this permit including Section B (Title V General Requirements) and/or Section E (Source Group Restrictions).

VI. WORK PRACTICE REQUIREMENTS.

No additional work practice requirements exist except as provided in other sections of this permit including Section B (Title V General Requirements) and/or Section E (Source Group Restrictions).

VII. ADDITIONAL REQUIREMENTS.

No additional requirements exist except as provided in other sections of this permit including Section B (Title V General Requirements) and/or Section E (Source Group Restrictions).

***** Permit Shield in Effect. *****

**SECTION D. Source Level Requirements**

Source ID: 133

Source Name: WWTP LIME STORAGE SILO

Source Capacity/Throughput:

N/A

Conditions for this source occur in the following groups: GROUP 006

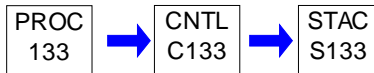
**I. RESTRICTIONS.****Emission Restriction(s).****# 001 [25 Pa. Code §127.512]****Operating permit terms and conditions.**

[Additional authority for this permit condition is also derived from 25 Pa. Code §127.1 and Plan Approval No. 67-05005E]

(a) The particulate matter (PM) emissions from the silo associated with Source ID 133 shall be controlled by a bin vent collector, which shall be operated at all times that lime is being transferred to Source ID 133.

(b) The concentration of PM in the effluent gas of the bin vent collector shall not exceed 0.01 grain per dry standard cubic foot.

II. TESTING REQUIREMENTS.

No additional testing requirements exist except as provided in other sections of this permit including Section B (Title V General Requirements) and/or Section E (Source Group Restrictions).

III. MONITORING REQUIREMENTS.**# 002 [25 Pa. Code §127.511]****Monitoring and related recordkeeping and reporting requirements.**

[Additional authority for this permit condition is also derived from Plan Approval No. 67-05005E]

The permittee shall operate and maintain instrumentation to continuously monitor the pressure differential across the bin vent collector during silo loading operations.

IV. RECORDKEEPING REQUIREMENTS.**# 003 [25 Pa. Code §127.511]****Monitoring and related recordkeeping and reporting requirements.**

[Additional authority for this permit condition is also derived from Plan Approval No. 67-05005E]

(a) For the purpose of quantifying PM and PM10 emissions from the operation of Source ID 133, the permittee shall maintain records of the number of lime deliveries made to the facility during each month.

(b) All records shall be maintained at the facility for a period of five (5) years and shall be made available to the Department upon its request.

004 [25 Pa. Code §127.511]**Monitoring and related recordkeeping and reporting requirements.**

(a) The permittee shall maintain detailed records of all maintenance performed on Source ID 133's bin vent collector.

(b) The permittee shall retain these records for a minimum of five (5) years and shall make them available to the Department upon its request.

**SECTION D. Source Level Requirements****V. REPORTING REQUIREMENTS.**

No additional reporting requirements exist except as provided in other sections of this permit including Section B (Title V General Requirements) and/or Section E (Source Group Restrictions).

VI. WORK PRACTICE REQUIREMENTS.

005 [25 Pa. Code §127.512]

Operating permit terms and conditions.

[Additional authority for this permit condition is also derived from 25 Pa. Code §127.1 and Plan Approval No. 67-05005E]

(a) A sufficient quantity of spare bin vent collector bags shall be kept on hand at all times in order to replace any worn or damaged bags due to deterioration resulting from routine operation of Source ID 133.

(b) All lime removed from Source ID 133 shall be discharged into an enclosed system.

006 [25 Pa. Code §127.512]

Operating permit terms and conditions.

The permittee shall operate and maintain Source ID 133's bin vent collector in accordance with the manufacturer's specifications.

VII. ADDITIONAL REQUIREMENTS.

No additional requirements exist except as provided in other sections of this permit including Section B (Title V General Requirements) and/or Section E (Source Group Restrictions).

***** Permit Shield in Effect. *****

**SECTION D. Source Level Requirements**

Source ID: 140

Source Name: UNITS 1/2 MERCURY DRY SORBENT STORAGE SILO

Source Capacity/Throughput:

N/A

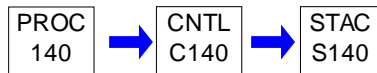
**I. RESTRICTIONS.****Emission Restriction(s).****# 001 [25 Pa. Code §127.1]****Purpose.**

[Additional authority for this permit condition is also derived from Plan Approval No. 67-05005]

Pursuant to the Best Available Technology (BAT) provisions of 25 Pa. Code §127.1, there shall be no visible air contaminant emissions from the exhaust of Source ID 140's bin vent collector other than water vapor or steam.

[Compliance with the requirement(s) specified in this streamlined plan approval condition assures compliance with the visible emission limits specified in 25 Pa. Code §123.41]

002 [25 Pa. Code §127.1]**Purpose.**

[Additional authority for this permit condition is also derived from Plan Approval No. 67-05005]

Pursuant to the Best Available Technology (BAT) provisions of 25 Pa. Code §127.1, no fugitive air contaminant emissions shall be generated as a result of removing collected dust from Source ID 140's bin vent collector or as a result of subsequently handling the collected dust on-site following its removal from the bin vent collector.

[Compliance with the requirement(s) specified in this streamlined plan approval condition assures compliance with the fugitive emission limit specified in 25 Pa. Code §123.1(a)]

003 [25 Pa. Code §127.1]**Purpose.**

[Additional authority for this permit condition is also derived from Plan Approval No. 67-05005]

Pursuant to the Best Available Technology (BAT) provisions of 25 Pa. Code §127.1, filterable and condensable particulate matter (PM) and PM10 emissions from Source ID 140's bin vent collector exhaust shall each not exceed 0.005 grain per dry standard cubic foot.

[Compliance with the requirement(s) specified in this streamlined plan approval condition assures compliance with the PM emission limit specified in 25 Pa. Code §123.13(c)(1)(i)]

004 [25 Pa. Code §127.512]**Operating permit terms and conditions.**

[Additional authority for this permit condition is also derived from Plan Approval No. 67-05005]

The permittee shall limit Source ID 140's annual emissions to less than or equal to the following thresholds during any consecutive 12-month period:

(a) 0.02 TPY of particulate matter (PM).

(b) 0.02 TPY of PM-10 (particulate matter having an effective aerodynamic diameter less than or equal to a nominal 10 micron body).

(c) 0.02 TPY of PM-2.5 (particulate matter having an effective aerodynamic diameter less than or equal to a nominal 2.5 micron body).

**SECTION D. Source Level Requirements****Operation Hours Restriction(s).****# 005 [25 Pa. Code §127.512]****Operating permit terms and conditions.**

[Additional authority for this permit condition is also derived from Plan Approval No. 67-05005]

Mercury dry sorbent shall not be transferred to Source ID 140 more than 730 hours during any consecutive 12-month period.

II. TESTING REQUIREMENTS.

No additional testing requirements exist except as provided in other sections of this permit including Section B (Title V General Requirements).

III. MONITORING REQUIREMENTS.**# 006 [25 Pa. Code §127.1]****Purpose.**

[Additional authority for this permit condition is also derived from Plan Approval No. 67-05005]

Pursuant to the Best Available Technology (BAT) provisions of 25 Pa. Code §127.1, the permittee shall operate and maintain instrumentation to continuously measure and display the pressure differential across Source ID 140's bin vent collector during silo loading operations.

IV. RECORDKEEPING REQUIREMENTS.**# 007 [25 Pa. Code §127.511]****Monitoring and related recordkeeping and reporting requirements.**

[Additional authority for this permit condition is also derived from Plan Approval No. 67-05005]

(a) The permittee shall monitor and record the pressure differential across Source ID 140's bin vent collector. The pressure differential shall be recorded during each silo loading operation while Source ID 140 and its bin vent collector are operating.

(b) The permittee shall retain these records for a minimum of five (5) years and shall make them available to the Department upon its request.

008 [25 Pa. Code §127.511]**Monitoring and related recordkeeping and reporting requirements.**

[Additional authority for this permit condition is also derived from Plan Approval No. 67-05005]

(a) The permittee shall maintain records of the monthly hours that mercury dry sorbent is transferred to Source ID 140.

(b) The permittee shall maintain records of the cumulative hours that mercury dry sorbent is transferred to Source ID 140 for each consecutive 12-month period. This is necessary in order to demonstrate compliance with Condition #005, above.

(c) The permittee shall retain these records for a minimum of five (5) years. The records shall be made available to the Department upon its request.

009 [25 Pa. Code §127.511]**Monitoring and related recordkeeping and reporting requirements.**

[Additional authority for this permit condition is also derived from Plan Approval No. 67-05005]

(a) The permittee shall calculate the monthly air emissions from Source ID 140 using AP-42 emission factors, manufacturer-supplied emission factors, mass material balance, performance (stack) test data, or other method(s) acceptable to the Department. The permittee shall maintain records of the monthly air emissions.

(b) The permittee shall calculate the cumulative Source ID 140 air emissions for each consecutive 12-month period. The

**SECTION D. Source Level Requirements**

permittee shall maintain records of the cumulative Source ID 140 air emissions for each consecutive 12-month period in order to demonstrate compliance with Condition #004, above.

(c) The permittee shall retain these records for a minimum of five (5) years. The records shall be made available to the Department upon its request.

010 [25 Pa. Code §127.511]**Monitoring and related recordkeeping and reporting requirements.**

[Additional authority for this permit condition is also derived from Plan Approval No. 67-05005]

(a) The permittee shall maintain detailed records of all maintenance performed on Source ID 140's bin vent collector.

(b) The permittee shall retain these records for a minimum of five (5) years and shall make them available to the Department upon its request.

V. REPORTING REQUIREMENTS.

No additional reporting requirements exist except as provided in other sections of this permit including Section B (Title V General Requirements).

VI. WORK PRACTICE REQUIREMENTS.**# 011 [25 Pa. Code §127.1]****Purpose.**

[Additional authority for this permit condition is also derived from Plan Approval No. 67-05005]

Pursuant to the Best Available Technology (BAT) provisions of 25 Pa. Code §127.1, the permittee shall operate Source ID 140's bin vent collector at all times that mercury dry sorbent is being transferred to Source ID 140.

012 [25 Pa. Code §127.1]**Purpose.**

[Additional authority for this permit condition is also derived from Plan Approval No. 67-05005]

Pursuant to the Best Available Technology (BAT) provisions of 25 Pa. Code §127.1, the permittee shall maintain on-site a sufficient quantity of spare bin vent collector bags for Source ID 140's bin vent collector in order to immediately replace any bags requiring replacement due to deterioration resulting from routine operation.

013 [25 Pa. Code §127.1]**Purpose.**

[Additional authority for this permit condition is also derived from Plan Approval No. 67-05005]

Pursuant to the Best Available Technology (BAT) provisions of 25 Pa. Code §127.1, Source ID 140's bin vent collector's compressed air supply shall be equipped with an air dryer and an oil trap.

014 [25 Pa. Code §127.1]**Purpose.**

[Additional authority for this permit condition is also derived from Plan Approval No. 67-05005]

Pursuant to the Best Available Technology (BAT) provisions of 25 Pa. Code §127.1, Source ID 140 and its bin vent collector shall be:

(a) Operated in such a manner as to not cause air pollution as that term is defined in the Air Pollution Control Act (35 P.S. §§4001 - 4015) and 25 Pa. Code §121.1;

(b) Operated and maintained in a manner consistent with good operating and maintenance practices; and

**SECTION D. Source Level Requirements**

(c) Operated and maintained in accordance with the manufacturer's specifications.

VII. ADDITIONAL REQUIREMENTS.

No additional requirements exist except as provided in other sections of this permit including Section B (Title V General Requirements).

***** Permit Shield in Effect. *****

**SECTION D. Source Level Requirements**

Source ID: 141

Source Name: UNIT 3 MERCURY DRY SORBENT STORAGE SILO

Source Capacity/Throughput:

N/A

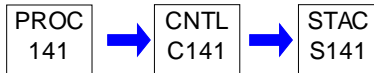
**I. RESTRICTIONS.****Emission Restriction(s).****# 001 [25 Pa. Code §123.1]****Prohibition of certain fugitive emissions**

[Additional authority for this permit condition is also derived from Plan Approval No. 67-05005]

Pursuant to the provisions of 25 Pa. Code §123.1(a), no fugitive air contaminant emissions shall be generated as a result of removing collected dust from Source ID 141's bin vent collector or as a result of subsequently handling the collected dust on-site following its removal from the bin vent collector.

002 [25 Pa. Code §123.13]**Processes**

[Additional authority for this permit condition is also derived from Plan Approval No. 67-05005]

Pursuant to the provisions of 25 Pa. Code §123.13(c)(1)(i), filterable particulate matter (PM) emissions from Source ID 141's bin vent collector exhaust shall not exceed 0.04 grain per dry standard cubic foot.

II. TESTING REQUIREMENTS.

No additional testing requirements exist except as provided in other sections of this permit including Section B (Title V General Requirements).

III. MONITORING REQUIREMENTS.**# 003 [25 Pa. Code §127.511]****Monitoring and related recordkeeping and reporting requirements.**

[Additional authority for this permit condition is also derived from Plan Approval No. 67-05005]

The permittee shall operate and maintain instrumentation to continuously measure and display the pressure differential across Source ID 141's bin vent collector during silo loading operations.

IV. RECORDKEEPING REQUIREMENTS.**# 004 [25 Pa. Code §127.511]****Monitoring and related recordkeeping and reporting requirements.**

[Additional authority for this permit condition is also derived from Plan Approval No. 67-05005]

(a) The permittee shall monitor and record the pressure differential across Source ID 141's bin vent collector. The pressure differential shall be recorded during each silo loading operation while Source ID 141 and its bin vent collector are operating.

(b) The permittee shall retain these records for a minimum of five (5) years and shall make them available to the Department upon its request.

005 [25 Pa. Code §127.511]**Monitoring and related recordkeeping and reporting requirements.**

[Additional authority for this permit condition is also derived from Plan Approval No. 67-05005]

**SECTION D. Source Level Requirements**

- (a) The permittee shall maintain detailed records of all maintenance performed on Source ID 141's bin vent collector.
- (b) The permittee shall retain these records for a minimum of five (5) years and shall make them available to the Department upon its request.

V. REPORTING REQUIREMENTS.

No additional reporting requirements exist except as provided in other sections of this permit including Section B (Title V General Requirements).

VI. WORK PRACTICE REQUIREMENTS.**# 006 [25 Pa. Code §127.512]****Operating permit terms and conditions.**

[Additional authority for this permit condition is also derived from Plan Approval No. 67-05005]

The permittee shall operate Source ID 141's bin vent collector at all times that mercury dry sorbent is being transferred to Source ID 141.

007 [25 Pa. Code §127.512]**Operating permit terms and conditions.**

[Additional authority for this permit condition is also derived from Plan Approval No. 67-05005]

The permittee shall maintain on-site a sufficient quantity of spare bin vent collector bags for Source ID 141's bin vent collector in order to immediately replace any bags requiring replacement due to deterioration resulting from routine operation.

008 [25 Pa. Code §127.512]**Operating permit terms and conditions.**

[Additional authority for this permit condition is also derived from Plan Approval No. 67-05005]

Source ID 141's bin vent collector's compressed air supply shall be equipped with an air dryer and an oil trap.

009 [25 Pa. Code §127.512]**Operating permit terms and conditions.**

[Additional authority for this permit condition is also derived from Plan Approval No. 67-05005]

Source ID 141 and its bin vent collector shall be:

- (a) Operated in such a manner as to not cause air pollution as that term is defined in the Air Pollution Control Act (35 P.S. §§4001 - 4015) and 25 Pa. Code §121.1;
- (b) Operated and maintained in a manner consistent with good operating and maintenance practices; and
- (c) Operated and maintained in accordance with the manufacturer's specifications.

VII. ADDITIONAL REQUIREMENTS.

No additional requirements exist except as provided in other sections of this permit including Section B (Title V General Requirements).

***** Permit Shield in Effect. *****

**SECTION D. Source Level Requirements**

Source ID: 150

Source Name: REFINED COAL SYSTEM

Source Capacity/Throughput:

N/A

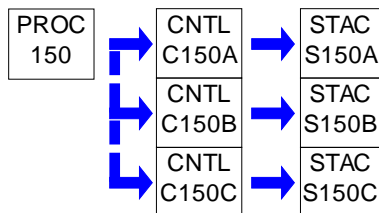
**I. RESTRICTIONS.****Emission Restriction(s).**

001 [25 Pa. Code §123.13]

Processes

Pursuant to 25 Pa. Code §123.13(c)(1)(i), filterable particulate matter (FPM) emissions from each Source ID 150 control device's exhaust shall not exceed 0.04 grain per dry standard cubic foot.

Throughput Restriction(s).

002 [25 Pa. Code §127.512]

Operating permit terms and conditions.

[Additional authority for this permit condition is also derived from RFD exemption letter dated 2/08/16 (re: RFD*Online RFD #5508)]

The permittee shall limit Source ID 150's annual coal throughput to 3.678 million tons during any consecutive 12-month period.

{RFD = Request for Determination of Changes of Minor Significance and Exemption from Plan Approval Requirements}

II. TESTING REQUIREMENTS.

No additional testing requirements exist except as provided in other sections of this permit including Section B (Title V General Requirements).

III. MONITORING REQUIREMENTS.

No additional monitoring requirements exist except as provided in other sections of this permit including Section B (Title V General Requirements).

IV. RECORDKEEPING REQUIREMENTS.

003 [25 Pa. Code §127.511]

Monitoring and related recordkeeping and reporting requirements.

[Additional authority for this permit condition is also derived from RFD exemption letter dated 2/08/16 (re: RFD*Online RFD #5508)]

(a) The permittee shall maintain records of Source ID 150's monthly coal throughput for the refined coal system.

(b) The permittee shall calculate the cumulative Source ID 150 coal throughput for each consecutive 12-month period. The permittee shall maintain records of the cumulative Source ID 150 coal throughput for each consecutive 12-month period in order to demonstrate compliance with Condition #002, above.

**SECTION D. Source Level Requirements**

(c) The permittee shall retain these records for a minimum of five (5) years. The records shall be made available to the Department upon its request.

{RFD = Request for Determination of Changes of Minor Significance and Exemption from Plan Approval Requirements}

V. REPORTING REQUIREMENTS.

No additional reporting requirements exist except as provided in other sections of this permit including Section B (Title V General Requirements).

VI. WORK PRACTICE REQUIREMENTS.**# 004 [25 Pa. Code §127.512]****Operating permit terms and conditions.**

The permittee shall operate each Source ID 150's bin vent collector, as applicable, at all times that solid sorbent is being transferred to its respective Source ID 150 storage bin/storage silo.

005 [25 Pa. Code §127.512]**Operating permit terms and conditions.**

Source ID 150 and its bin vent collectors shall be:

- (a) Operated in such a manner as to not cause air pollution as that term is defined in the Air Pollution Control Act (35 P.S. §§4001 - 4015) and 25 Pa. Code §121.1;
- (b) Operated and maintained in a manner consistent with good operating and maintenance practices; and
- (c) Operated and maintained in accordance with the manufacturer's specifications.

VII. ADDITIONAL REQUIREMENTS.

No additional requirements exist except as provided in other sections of this permit including Section B (Title V General Requirements).

***** Permit Shield in Effect. *****

**SECTION D. Source Level Requirements**

Source ID: 201

Source Name: REMOTE RESERVOIR COLD CLEANING MACHINES

Source Capacity/Throughput: 1.000 Lbs/HR VOC

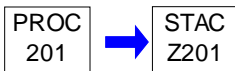
**I. RESTRICTIONS.****Throughput Restriction(s).****# 001 [25 Pa. Code §129.63]****Degreasing operations**

(a) The permittee may not use in any Source ID 201 machine any solvent with a vapor pressure of 1.0 millimeter of mercury (mm Hg) or greater and containing greater than 5% VOC by weight, measured at 20°C (68°F) containing VOCs.

(b) This operating permit condition does not apply:

(1) If a Source ID 201 machine is used in extreme cleaning service. Extreme cleaning service is defined as the use of a cold cleaning machine to clean parts used in the manufacture of the following gases or to clean parts exposed to these gases in manufacturing, production, research and development, analytical work, or other similar operations:

- (A) Oxygen in concentrations greater than 23%
- (B) Ozone
- (C) Nitrous oxide
- (D) Fluorine
- (E) Chlorine
- (F) Bromine
- (G) Halogenated compounds

(2) If the permittee demonstrates, and the Department approves in writing, that compliance with this operating permit condition will result in unsafe operating conditions.

II. TESTING REQUIREMENTS.

No additional testing requirements exist except as provided in other sections of this permit including Section B (Title V General Requirements).

III. MONITORING REQUIREMENTS.

No additional monitoring requirements exist except as provided in other sections of this permit including Section B (Title V General Requirements).

IV. RECORDKEEPING REQUIREMENTS.**# 002 [25 Pa. Code §129.63]****Degreasing operations**

The permittee shall maintain the following records for each Source ID 201 machine:

- (a) The name and address of the solvent supplier.
- (b) The type of solvent including the product or vendor identification number.
- (c) The vapor pressure of the solvent measured in mm Hg at 20°C (68°F).

An invoice, bill of sale, certificate that corresponds to a number of sales, Material Safety Data Sheet (MSDS), or other appropriate documentation acceptable to the Department may be used to comply with this operating permit condition.

**SECTION D. Source Level Requirements**

The permittee shall retain these records for a minimum of five (5) years and shall make them available to the Department upon its request.

V. REPORTING REQUIREMENTS.

No additional reporting requirements exist except as provided in other sections of this permit including Section B (Title V General Requirements).

VI. WORK PRACTICE REQUIREMENTS.**# 003 [25 Pa. Code §129.63]****Degreasing operations**

Each Source ID 201 machine shall be equipped with one of the following:

- (a) A cover that shall be closed at all times except during cleaning of parts or the addition or removal of solvent; or
- (b) A perforated drain with a diameter of not more than six (6) inches, if the Source ID 201 machine drains directly into the solvent storage reservoir.

004 [25 Pa. Code §129.63]**Degreasing operations**

The permittee shall operate each Source ID 201 machine in accordance with the following procedures:

- (a) Waste solvent shall be collected and stored in closed containers. The closed containers may contain a device that allows pressure relief, but does not allow liquid solvent to drain from the container.
- (b) Flushing of parts using a flexible hose or other flushing device shall be performed only within the Source ID 201 machine. The solvent spray shall be a solid fluid stream, not an atomized or shower spray.
- (c) Sponges, fabric, wood, leather, paper products and other absorbent materials may not be cleaned in any Source ID 201 machine.
- (d) Air-agitated solvent baths may not be used.
- (e) Spills during solvent transfer and use of any Source ID 201 machine shall be cleaned up immediately.

005 [25 Pa. Code §129.63]**Degreasing operations**

Each Source ID 201 machine shall have a permanent, conspicuous label summarizing the operating requirements in Condition #004, above. In addition, the label shall include the following discretionary good operating practices:

- (a) Cleaned parts should be drained at least 15 seconds or until dripping ceases, whichever is longer. Parts having cavities or blind holes shall be tipped or rotated while the part is draining. During the draining, tipping or rotating, the parts should be positioned so that solvent drains directly back to the Source ID 201 machine.
- (b) When a pump-agitated solvent bath is used, the agitator should be operated to produce a rolling motion of the solvent with no observable splashing of the solvent against the tank walls or the parts being cleaned.
- (c) Work area fans should be located and positioned so that they do not blow across the opening of the degreaser unit.

VII. ADDITIONAL REQUIREMENTS.**# 006 [25 Pa. Code §129.63]****Degreasing operations**

All of the aforementioned operating permit conditions apply to a Source ID 201 cold cleaning machine so long as the

**SECTION D. Source Level Requirements**

machine uses 2 gallons or more of solvents containing greater than 5% VOC content by weight for the cleaning of metal parts.

***** Permit Shield in Effect. *****

**SECTION D. Source Level Requirements**

Source ID: 301

Source Name: NATURAL GAS PIPELINE (PROCESS)

Source Capacity/Throughput:

N/A

Natural Gas

Conditions for this source occur in the following groups: GROUP 014

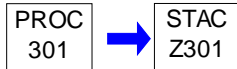
**I. RESTRICTIONS.**

No additional requirements exist except as provided in other sections of this permit including Section B (Title V General Requirements) and/or Section E (Source Group Restrictions).

II. TESTING REQUIREMENTS.

No additional testing requirements exist except as provided in other sections of this permit including Section B (Title V General Requirements) and/or Section E (Source Group Restrictions).

III. MONITORING REQUIREMENTS.

No additional monitoring requirements exist except as provided in other sections of this permit including Section B (Title V General Requirements) and/or Section E (Source Group Restrictions).

IV. RECORDKEEPING REQUIREMENTS.

No additional record keeping requirements exist except as provided in other sections of this permit including Section B (Title V General Requirements) and/or Section E (Source Group Restrictions).

V. REPORTING REQUIREMENTS.

No additional reporting requirements exist except as provided in other sections of this permit including Section B (Title V General Requirements) and/or Section E (Source Group Restrictions).

VI. WORK PRACTICE REQUIREMENTS.

No additional work practice requirements exist except as provided in other sections of this permit including Section B (Title V General Requirements) and/or Section E (Source Group Restrictions).

VII. ADDITIONAL REQUIREMENTS.

No additional requirements exist except as provided in other sections of this permit including Section B (Title V General Requirements) and/or Section E (Source Group Restrictions).

***** Permit Shield in Effect. *****

**SECTION D. Source Level Requirements**

Source ID: 401

Source Name: UNIT 1 EMERGENCY ENGINE

Source Capacity/Throughput:

Conditions for this source occur in the following groups: GROUP 013

GROUP 015

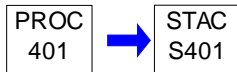
**I. RESTRICTIONS.**

No additional requirements exist except as provided in other sections of this permit including Section B (Title V General Requirements) and/or Section E (Source Group Restrictions).

II. TESTING REQUIREMENTS.

No additional testing requirements exist except as provided in other sections of this permit including Section B (Title V General Requirements) and/or Section E (Source Group Restrictions).

III. MONITORING REQUIREMENTS.

No additional monitoring requirements exist except as provided in other sections of this permit including Section B (Title V General Requirements) and/or Section E (Source Group Restrictions).

IV. RECORDKEEPING REQUIREMENTS.

No additional record keeping requirements exist except as provided in other sections of this permit including Section B (Title V General Requirements) and/or Section E (Source Group Restrictions).

V. REPORTING REQUIREMENTS.

No additional reporting requirements exist except as provided in other sections of this permit including Section B (Title V General Requirements) and/or Section E (Source Group Restrictions).

VI. WORK PRACTICE REQUIREMENTS.

No additional work practice requirements exist except as provided in other sections of this permit including Section B (Title V General Requirements) and/or Section E (Source Group Restrictions).

VII. ADDITIONAL REQUIREMENTS.

No additional requirements exist except as provided in other sections of this permit including Section B (Title V General Requirements) and/or Section E (Source Group Restrictions).

***** Permit Shield in Effect. *****

**SECTION D. Source Level Requirements**

Source ID: 402

Source Name: UNIT 3 EMERGENCY ENGINE

Source Capacity/Throughput:

Conditions for this source occur in the following groups: GROUP 013
GROUP 015

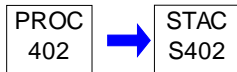
**I. RESTRICTIONS.**

No additional requirements exist except as provided in other sections of this permit including Section B (Title V General Requirements) and/or Section E (Source Group Restrictions).

II. TESTING REQUIREMENTS.

No additional testing requirements exist except as provided in other sections of this permit including Section B (Title V General Requirements) and/or Section E (Source Group Restrictions).

III. MONITORING REQUIREMENTS.

No additional monitoring requirements exist except as provided in other sections of this permit including Section B (Title V General Requirements) and/or Section E (Source Group Restrictions).

IV. RECORDKEEPING REQUIREMENTS.

No additional record keeping requirements exist except as provided in other sections of this permit including Section B (Title V General Requirements) and/or Section E (Source Group Restrictions).

V. REPORTING REQUIREMENTS.

No additional reporting requirements exist except as provided in other sections of this permit including Section B (Title V General Requirements) and/or Section E (Source Group Restrictions).

VI. WORK PRACTICE REQUIREMENTS.

No additional work practice requirements exist except as provided in other sections of this permit including Section B (Title V General Requirements) and/or Section E (Source Group Restrictions).

VII. ADDITIONAL REQUIREMENTS.

No additional requirements exist except as provided in other sections of this permit including Section B (Title V General Requirements) and/or Section E (Source Group Restrictions).

***** Permit Shield in Effect. *****

**SECTION D. Source Level Requirements**

Source ID: 403

Source Name: EMERGENCY SUMP PUMP ENGINE

Source Capacity/Throughput:

Conditions for this source occur in the following groups: GROUP 013

GROUP 015

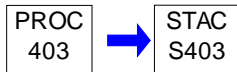
**I. RESTRICTIONS.**

No additional requirements exist except as provided in other sections of this permit including Section B (Title V General Requirements) and/or Section E (Source Group Restrictions).

II. TESTING REQUIREMENTS.

No additional testing requirements exist except as provided in other sections of this permit including Section B (Title V General Requirements) and/or Section E (Source Group Restrictions).

III. MONITORING REQUIREMENTS.

No additional monitoring requirements exist except as provided in other sections of this permit including Section B (Title V General Requirements) and/or Section E (Source Group Restrictions).

IV. RECORDKEEPING REQUIREMENTS.

No additional record keeping requirements exist except as provided in other sections of this permit including Section B (Title V General Requirements) and/or Section E (Source Group Restrictions).

V. REPORTING REQUIREMENTS.

No additional reporting requirements exist except as provided in other sections of this permit including Section B (Title V General Requirements) and/or Section E (Source Group Restrictions).

VI. WORK PRACTICE REQUIREMENTS.

No additional work practice requirements exist except as provided in other sections of this permit including Section B (Title V General Requirements) and/or Section E (Source Group Restrictions).

VII. ADDITIONAL REQUIREMENTS.

No additional requirements exist except as provided in other sections of this permit including Section B (Title V General Requirements) and/or Section E (Source Group Restrictions).

***** Permit Shield in Effect. *****

**SECTION D. Source Level Requirements**

Source ID: 404

Source Name: SERVICE WATER PUMP #3 ENGINE

Source Capacity/Throughput:

Conditions for this source occur in the following groups: GROUP 013

GROUP 015

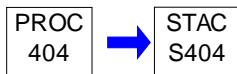
**I. RESTRICTIONS.**

No additional requirements exist except as provided in other sections of this permit including Section B (Title V General Requirements) and/or Section E (Source Group Restrictions).

II. TESTING REQUIREMENTS.

No additional testing requirements exist except as provided in other sections of this permit including Section B (Title V General Requirements) and/or Section E (Source Group Restrictions).

III. MONITORING REQUIREMENTS.

No additional monitoring requirements exist except as provided in other sections of this permit including Section B (Title V General Requirements) and/or Section E (Source Group Restrictions).

IV. RECORDKEEPING REQUIREMENTS.

No additional record keeping requirements exist except as provided in other sections of this permit including Section B (Title V General Requirements) and/or Section E (Source Group Restrictions).

V. REPORTING REQUIREMENTS.

No additional reporting requirements exist except as provided in other sections of this permit including Section B (Title V General Requirements) and/or Section E (Source Group Restrictions).

VI. WORK PRACTICE REQUIREMENTS.

No additional work practice requirements exist except as provided in other sections of this permit including Section B (Title V General Requirements) and/or Section E (Source Group Restrictions).

VII. ADDITIONAL REQUIREMENTS.

No additional requirements exist except as provided in other sections of this permit including Section B (Title V General Requirements) and/or Section E (Source Group Restrictions).

***** Permit Shield in Effect. *****

**SECTION E. Source Group Restrictions.**

Group Name: GROUP 001

Group Description: Utility Boilers

Sources included in this group

ID	Name
031A	BRUNNER ISLAND UNIT 1
032	BRUNNER ISLAND UNIT 2
033A	BRUNNER ISLAND UNIT 3

I. RESTRICTIONS.**Emission Restriction(s).****# 001 [25 Pa. Code §123.11]****Combustion units**

[Additional authority for this permit condition is also derived from Plan Approval Nos. 67-05005C and 67-05005F]

Pursuant to 25 Pa. Code §123.11(a)(3), the permittee shall not allow the emission of filterable particulate matter (FPM) into the outdoor atmosphere from each Group 001 boiler in excess of 0.1 pound per million BTU of heat input.

002 [25 Pa. Code §127.512]**Operating permit terms and conditions.**

[Additional authority for this permit condition is also derived from Plan Approval No. 67-05005D]

The permittee shall limit the emissions of sulfur oxides, expressed as SO₂, from each Group 001 boiler to 0.85 pound per million BTU per hour of heat input based on a 3-hour block average.

[NOTE: Compliance with the requirement(s) specified in this streamlined permit condition assures compliance with the SO_x emission limits specified in 40 CFR §52.2020 and 25 Pa. Code §123.22(a)(4)(iii)]

003 [25 Pa. Code §129.91]**Control of major sources of NO_x and VOCs**

[Additional authority for this permit condition is also derived from RACT Operating Permit No. 67-2005]

The permittee shall limit the NO_x emissions from the Group 001 boilers to 0.45 pound per million BTU based on hourly continuous emission monitoring data averaged on a 30-day rolling basis.

Fuel Restriction(s).**# 004 [25 Pa. Code §123.22]****Combustion units**

(a) Nonair basin areas. Combustion units in nonair basin areas must conform with the following:

(1) [NOTE: SUPERSEDED BY SUBPARAGRAPH (4), BELOW]

(2) Commercial fuel oil.

(i) Except as specified in subparagraphs (ii) and (iii), below, a person may not offer for sale, deliver for use, exchange in trade or permit the use of commercial fuel oil in nonair basin areas if the commercial fuel oil contains sulfur in excess of the applicable maximum allowable sulfur content set forth as follows:

Maximum Allowable % Sulfur by Weight through June 30, 2016, based on Grades Commercial Fuel Oil:

No. 2 and Lighter (viscosity less than or equal to 5.820cSt): 0.5% by weight

Maximum Allowable Sulfur Content Beginning July 1, 2016, Expressed as Parts per Million (ppm) by Weight or Percentage by Weight, based on Grades Commercial Fuel Oil (Consistent with ASTM D396):

No. 2 and lighter oil: 500 ppm by weight (0.05% by weight)

**SECTION E. Source Group Restrictions.**

(ii) Commercial fuel oil that was stored in this Commonwealth by the ultimate consumer prior to July 1, 2016, which met the applicable maximum allowable sulfur content for commercial fuel oil through June 30, 2016, in subparagraph (i), above, at the time it was stored, may be used by the ultimate consumer in this Commonwealth on and after July 1, 2016.

(iii) Beginning July 1, 2016, the Department may temporarily suspend or increase the applicable maximum allowable sulfur content for a commercial fuel oil set forth in subparagraph (i), above, if the following occur [NOTE: DETAILS INCORPORATED BY REFERENCE, INCLUDING SUBPARAGRAPH (iv)]

(3) [N/A - EQUIVALENCY NOT ELECTED BY PERMITTEE]

(4) [N/A - SUPERSEDED BY SECTION E (GROUP 001), CONDITION #002, ABOVE]

(b) [N/A - FACILITY NOT LOCATED IN ERIE; HARRISBURG; YORK; LANCASTER; AND SCRANTON, WILKES-BARRE AIR BASINS]

(c) [N/A - FACILITY NOT LOCATED IN ALLENTOWN, BETHLEHEM, EASTON; READING; UPPER BEAVER VALLEY; AND JOHNSTOWN AIR BASINS]

(d) [N/A - FACILITY NOT LOCATED IN ALLEGHENY COUNTY; LOWER BEAVER VALLEY; AND MONONGAHELA VALLEY AIR BASINS]

(e) [N/A - FACILITY NOT LOCATED IN SOUTHEAST PENNSYLVANIA AIR BASIN]

(f) Sampling and testing.

(1) [NOTE: COVERED UNDER PARAGRAPH (g), BELOW, FOR THE ULTIMATE FUEL CONSUMER]

(2) [N/A - FACILITY IS NOT A REFINERY]

(3) [N/A - FACILITY IS NOT A PERSON OTHER THAN THE ULTIMATE FUEL CONSUMER]

(g) Recordkeeping and reporting.

(1) Beginning with the refinery owner or operator who sells or transfers commercial fuel oil into or within this Commonwealth for use in this Commonwealth and ending with the ultimate consumer, each time the physical custody of, or title to, a shipment of commercial fuel oil changes hands on or after July 1, 2016, the transferor shall provide to the transferee an electronic or paper record described in this paragraph. This record must legibly and conspicuously contain the following information:

(i) The date of the sale or transfer.

(ii) The name and address of the transferor.

(iii) The name and address of the transferee.

(iv) The volume of commercial fuel oil being sold or transferred.

(v) The identification of the sulfur content of the shipment of commercial fuel oil, determined using the sampling and testing methods specified in subsection (f)(1), above, expressed as one of the following statements:

(A) For a shipment of No. 2 and lighter commercial fuel oil, "The sulfur content of this shipment is 500 ppm or below."

(B) [N/A – UNITS DO NOT USE NO. 4 OIL]

(C) [N/A – UNITS DO NOT USE NO. 5, NO. 6 OR HEAVIER GRADES OF OIL]

(vi) The location of the commercial fuel oil at the time of transfer.

**SECTION E. Source Group Restrictions.**

(vii) Except for a transfer to a truck carrier, an owner or operator of a retail outlet or an ultimate consumer, the transferor may substitute the information required under subparagraphs (i) - (vi), above, with the use of a product code if the following are met:

- (A) The product code includes the information required under subparagraphs (i) - (vi), above.
 - (B) The product code is standardized throughout the distribution system in which it is used.
 - (C) Each downstream party is given sufficient information to know the full meaning of the product code.
- (2) [N/A - FACILITY IS NOT A REFINERY]
- (3) [N/A - FACILITY IS NOT A TERMINAL]
- (4) A person subject to this section (25 Pa. Code §123.22) shall do both of the following:
- (i) Maintain the applicable records required under paragraphs (1) - (3), above, in electronic or paper format for 2 years unless a longer period is required under 25 Pa. Code §127.511(b)(2) (relating to monitoring and related recordkeeping and reporting requirements).
 - (ii) Provide an electronic or written copy of the applicable record to the Department upon request.
- (5) The ultimate consumer shall maintain in electronic or paper format the record containing the information listed in paragraph (1), above, except in either of the following situations:
- (i) [N/A - FACILITY IS NOT A PRIVATE RESIDENCE]
 - (ii) [N/A - FACILITY IS NOT A RESIDENTIAL HOUSING INSTALLATION]

(h) Written request. The written request for suspension of or increase in the sulfur content limit on the basis that compliant commercial fuel oil is not reasonably available shall be addressed to the Department of Environmental Protection, Bureau of Air Quality, Chief of the Division of Compliance and Enforcement, P.O. Box 8468, Harrisburg, Pennsylvania 17105-8468.

005 [25 Pa. Code §127.512]**Operating permit terms and conditions.**

[Additional authority for the natural gas fuel combustion component of this permit condition is also derived from Plan Approval No. 67-05005H]

The permittee shall operate each Group 001 boiler (and associated coal mill heaters) using either bituminous coal, No. 2 fuel oil, or natural gas fuel only. The bituminous coal may be treated with materials of which the Department has approved in writing.

006 [25 Pa. Code §127.512]**Operating permit terms and conditions.**

All terms in this condition are as defined in Consent Decree #1:18-CV-01042-CCC dated May 17, 2018.

1. By the end of the Ozone Season of 2022, the permittee shall cease combustion of coal at Brunner Island during the Ozone Season (May 1 through September 30 of any calendar year), except that such combustion shall be allowed during each Ozone Season in the interim period from January 1, 2023 to December 31, 2028 (Interim Period), as long as the following conditions are met:

a. The 30-Day Rolling Average NOx Emission Rate (for Brunner Island Units 1-3) is at or below 0.12 lbs./MMBtu, calculated at the end of each operating day during each Interim Period Ozone Season when coal has been burned, with the first compliance demonstration made at the end of the 30th operating day in each Ozone Season during which coal has been burned. The permittee shall notify DEP of each operating day when coal was burned during the Ozone Season, within thirty (30) days after the end of any Ozone Season during which coal was burned.

**SECTION E. Source Group Restrictions.**

b. Brunner Island shall emit less than 6,800,000 tons of carbon dioxide ("CO₂") from Brunner Island Units 1-3 per calendar year during which coal has been burned during the Ozone Season during the Interim Period.

2. By December 31, 2028, the permittee shall cease combustion of coal at Brunner Island, other than during periods of time (including time required for startup and shutdown) when PJM has declared an Emergency Action as defined in PJM Manual 13 (Emergency Operations) or an equivalent standard, and when gas is not available or the supply of gas to Brunner Island is interrupted.

3. The 30-Day Rolling Average NO_x Emission Rate (for Brunner Island Units 1-3) during the Ozone Season shall be determined using the methodology found in PA Code 129.100 (a)(1)(i)-(iii) (for units measuring emissions with continuous emissions monitors (CEMs)), with total NO_x emissions and total heat input from Brunner Island Units 1-3 used in the calculation. Furthermore, an operating day shall be defined as one with emissions reported from any one of the three units. For the purposes of this permit condition, Day shall mean, unless otherwise specified, calendar day.

II. TESTING REQUIREMENTS.**# 007 [25 Pa. Code §139.11]****General requirements.**

(a) Pursuant to 25 Pa. Code §139.3, at least 90 calendar days prior to commencing an emissions testing program, unless otherwise approved in writing by the Department, a test protocol shall be submitted to the Department for review and approval. Unless otherwise approved in writing by the Department, the permittee shall not conduct the test that is the subject of the protocol until the test protocol has been approved in writing by the Department.

(b) Pursuant to 25 Pa. Code §139.3, at least 15 calendar days prior to commencing an emissions testing program, notification as to the date and time of testing shall be given to the Southcentral Regional Office. Notification shall also be sent to the Bureau of Air Quality's Division of Source Testing and Monitoring. Notification shall not be made without prior receipt of a protocol acceptance letter from the Department.

(c) Pursuant to 25 Pa. Code §139.53(a)(3), within 15 calendar days after completion of the on-site testing portion of an emission test program, if a complete test report has not yet been submitted, an electronic mail notification shall be sent to the Bureau of Air Quality's Division of Source Testing and Monitoring and the Southcentral Regional Office indicating the completion date of the on-site testing.

(d) Pursuant to 25 Pa. Code §139.3 and 40 CFR §63.7(g)(1), a complete test report shall be submitted to the Department no later than 60 calendar days after completion of the on-site testing portion of an emissions test program.

(e) Pursuant to 25 Pa. Code §139.53(b), a complete test report shall include a summary of the emissions results on the first page of the report indicating if each pollutant measured is within permitted limits and a statement of compliance or non-compliance with all applicable plan approval/operating permit conditions. The summary results shall include, at a minimum, the following information:

(1) A statement that the owner or operator has reviewed the report from the emissions testing body and agrees with the findings.

(2) Plan approval/operating permit number(s) and condition(s) which are the basis for the evaluation.

(3) Summary of results with respect to each applicable plan approval/operating permit condition.

(4) Statement of compliance or non-compliance with each applicable plan approval/operating permit condition.

(f) Pursuant to 25 Pa. Code §139.3, all submittals shall meet all applicable requirements specified in the most current version of the Department's Source Testing Manual.

(g) All testing shall be performed in accordance with the provisions of Chapter 139 of the Rules and Regulations of the Department.

(h) Pursuant to 25 Pa. Code §§139.53(a)(1) and 139.53(a)(3), all submittals, besides notifications, shall be accomplished via PSIMS*Online available via <https://www.depgreenport.state.pa.us/ecom/Login.jsp>. If internet submittal cannot be accomplished, one digital copy of each submittal shall be made to each of the following:

**SECTION E. Source Group Restrictions.**

Southcentral Regional Office:
Digital copy: RA-epsctestesting@pa.gov

Bureau of Air Quality:
Digital copy: RA-epstacktesting@pa.gov

(1) A complete paper copy of each submittal shall be made to: PA DEP, Bureau of Air Quality, Division of Source Testing and Monitoring, 400 Market Street, 12th Floor Rachael Carson State Office Building, Harrisburg, PA 17105-8468.

(2) A paper copy of (only) the cover letter/page (for both protocols and reports) and summary table (for reports only), of each submittal shall be made to: Program Manager, Air Quality Program, PA DEP Southcentral Regional Office, 909 Elmerton Avenue, Harrisburg, PA 17110.

(i) The permittee shall ensure all federal reporting requirements contained in any applicable federal subpart are followed, including timelines more stringent than those contained herein. In the event of an inconsistency or any conflicting state and federal requirements, the most stringent provision, term, condition, method or rule shall be used by default.

III. MONITORING REQUIREMENTS.**# 008 [25 Pa. Code §127.511]****Monitoring and related recordkeeping and reporting requirements.**

[Additional authority for this permit condition is also derived from Plan Approval No. 67-05005D]

The permittee shall operate and maintain devices to monitor the following parameters for each of the FGD scrubbers associated with the Group 001 boilers:

- (1) The pressure differential across the absorber.
- (2) The flue gas pressure across the mist eliminator.
- (3) The inlet and outlet temperatures.
- (4) The pH of the scrubbing liquid.
- (5) The density of the reactor tank slurry.

IV. RECORDKEEPING REQUIREMENTS.**# 009 [25 Pa. Code §129.95]****Recordkeeping**

[Additional authority for this permit condition is also derived from RACT Operating Permit No. 67-2005]

- (a) The permittee shall maintain records of each Group 001 boiler's NOx emission rate data in order to demonstrate compliance with Condition #003, above.
- (b) The permittee shall retain these records for a minimum of five (5) years. The records shall be made available to the Department upon its request.

V. REPORTING REQUIREMENTS.

No additional reporting requirements exist except as provided in other sections of this permit including Section B (Title V General Requirements).

VI. WORK PRACTICE REQUIREMENTS.**# 010 [25 Pa. Code §127.512]****Operating permit terms and conditions.**

Unless otherwise approved in writing by the Department, the permittee shall operate and maintain the FGD scrubbers associated with the Group 001 boilers in accordance with the operation & maintenance (O&M) plan that was received and approved by the Department on February 5, 2010.

011 [25 Pa. Code §127.512]**Operating permit terms and conditions.**

The permittee may burn the chemical cleaning rinse water generated by the Group 001 boilers in the Group 001 boilers

**SECTION E. Source Group Restrictions.**

provided the rinse water does not significantly change the following:

- (a) The composition of the bottom ash.
- (b) The quantity or composition of particulate matter carried out by the flue gases.
- (c) The quantity or composition of the flue gases.

VII. ADDITIONAL REQUIREMENTS.

012 [25 Pa. Code §127.512]

Operating permit terms and conditions.

[Additional authority for this permit condition is also derived from Plan Approval No. 67-05005D]

- (a) Each Group 001 boiler shall exhaust to the atmosphere at a height of no less than 524 feet above grade.
- (b) The inside diameter of each Group 001 boiler's FGD scrubber flue shall be no greater than 30.68 feet at the point of exhaust.

***** Permit Shield in Effect. *****

**SECTION E. Source Group Restrictions.**

Group Name: GROUP 004

Group Description: Acid Rain Program Provisions

Sources included in this group

ID	Name
031A	BRUNNER ISLAND UNIT 1
032	BRUNNER ISLAND UNIT 2
033A	BRUNNER ISLAND UNIT 3

I. RESTRICTIONS.**Emission Restriction(s).****# 001 [25 Pa. Code §127.531]****Special conditions related to acid rain.**

(a) The Group 004 boilers are subject to the Title IV Acid Rain Provisions of the Clean Air Act Amendments of 1990 and shall comply with all applicable requirements of that Title and include the following:

- 40 CFR Part 72 Permit Regulation
- 40 CFR Part 73 Sulfur Dioxide Allowance System
- 40 CFR Part 75 Continuous Emission Monitoring
- 40 CFR Part 76 Nitrogen Oxides Emission Reduction Program
- 40 CFR Part 77 Excess Emissions

Note: The Acid Rain identification for the facility is ORIS: 3140

(b) The Acid Rain Provisions of Title IV prohibit the following:

- (1) Annual emissions of sulfur dioxide in excess of the number of allowances to emit sulfur dioxide that the permittee or designated representative holds for the unit.
- (2) Exceeding applicable emission rates or standards, including ambient air quality standards.
- (3) The use of an allowance prior to the year for which it is allocated.
- (4) Contravention of other provisions of the permit.

(c) The Acid Rain Provisions prohibit the emission of sulfur dioxide which exceeds any allowances that the source lawfully holds under Title IV of the Clean Air Act or the regulations thereunder.

(1) A permit revision will not be required for increases in emissions that are authorized by allowances acquired pursuant to the acid rain program, if the increases do not require a permit revision under another applicable requirement.

(2) A limit will not be placed on the number of allowances held by the source. The source may not, however, use allowances as a defense to noncompliance with another applicable requirement.

(3) An allowance shall be accounted for according to the procedures established in regulations promulgated under Title IV of the Clean Air Act.

002 [25 Pa. Code §127.531]**Special conditions related to acid rain.**

The SO₂ allowance allocations for the Group 004 boilers under the Title IV provisions are the following:

Unit No. 1 (Source ID 031A)

- 2020 = 11,992 tons
- 2021 = 11,992 tons
- 2022 = 11,992 tons
- 2023 = 11,992 tons

**SECTION E. Source Group Restrictions.**

2024 = 11,992 tons
2025 = 11,992 tons

Unit No. 2 (Source ID 032)

2020 = 13,437 tons
2021 = 13,437 tons
2022 = 13,437 tons
2023 = 13,437 tons
2024 = 13,437 tons
2025 = 13,437 tons

Unit No. 3 (Source ID 033A)

2020 = 23,250 tons
2021 = 23,250 tons
2022 = 23,250 tons
2023 = 23,250 tons
2024 = 23,250 tons
2025 = 23,250 tons

003 [25 Pa. Code §127.531]**Special conditions related to acid rain.**

The NOx requirements for the Group 004 boilers under the Title IV provisions are the following:

- (a) Unit No. 1 (Source ID 031A) = 0.45 pounds per million BTU (annual average).
- (b) Unit No. 2 (Source ID 032) = 0.45 pounds per million BTU (annual average).
- (c) Unit No. 3 (Source ID 033A) = 0.45 pounds per million BTU (annual average).

II. TESTING REQUIREMENTS.

No additional testing requirements exist except as provided in other sections of this permit including Section B (Title V General Requirements).

III. MONITORING REQUIREMENTS.

No additional monitoring requirements exist except as provided in other sections of this permit including Section B (Title V General Requirements).

IV. RECORDKEEPING REQUIREMENTS.**# 004 [25 Pa. Code §127.511]****Monitoring and related recordkeeping and reporting requirements.**

- (a) The permittee shall keep sufficient records to demonstrate compliance with Conditions #002 and #003, above.
- (b) The permittee shall retain these records for a minimum of five (5) years. The records shall be made available to the Department upon its request.

V. REPORTING REQUIREMENTS.

No additional reporting requirements exist except as provided in other sections of this permit including Section B (Title V General Requirements).

**SECTION E. Source Group Restrictions.****VI. WORK PRACTICE REQUIREMENTS.**

No additional work practice requirements exist except as provided in other sections of this permit including Section B (Title V General Requirements).

VII. ADDITIONAL REQUIREMENTS.

No additional requirements exist except as provided in other sections of this permit including Section B (Title V General Requirements).

***** Permit Shield in Effect. *****

**SECTION E. Source Group Restrictions.**

Group Name: GROUP 005

Group Description: Emergency Quench Pump Engines

Sources included in this group

ID	Name
037	DIESEL- FIRED QUENCH PUMP 1
038	DIESEL- FIRED QUENCH PUMP 2

I. RESTRICTIONS.**Emission Restriction(s).****# 001 [25 Pa. Code §127.512]****Operating permit terms and conditions.**

[Additional authority for this permit condition is also derived from 25 Pa. Code §§123.13(c)(1)(i), 123.21, and 127.1, and Plan Approval No. 67-05005D]

(a) The permittee shall not allow the emission into the outdoor atmosphere of sulfur oxides from either Group 005 source in a manner that the concentration of the sulfur oxides (expressed as SO₂) in the effluent gas exceeds 500 parts per million, by volume, dry basis.

(b) Pursuant to the Best Available Technology (BAT) provisions of 25 Pa. Code §127.1, the permittee shall not allow the emission into the outdoor atmosphere of visible air contaminants from either Group 005 source in such a manner that the opacity of the emission is either of the following:

- (1) Equal to or greater than 10% for a period or periods aggregating more than three (3) minutes in any one (1) hour.
- (2) Equal to or greater than 30% at any time.

(c) The permittee shall not allow the emission into the outdoor atmosphere of filterable particulate matter (PM) from either Group 005 source in a manner that the concentration of PM in the effluent gas exceeds 0.04 grain per dry standard cubic foot.

[NOTE: Compliance with the requirement(s) specified in part (b) of this streamlined permit condition assures compliance with the visible emissions limit specified in 25 Pa. Code §123.41]

002 [25 Pa. Code §127.512]**Operating permit terms and conditions.**

[Additional authority for this permit condition is also derived from 25 Pa. Code §127.1 and Plan Approval No. 67-05005D]

(a) The emissions from each Group 005 source shall not exceed the following Best Available Technology (BAT) limits:

- (1) 6.9 grams NO_x/bhp-hr
- (2) 2.0 grams CO/bhp-hr
- (3) 1.0 gram THC/bhp-hr
- (4) 0.4 gram PM/bhp-hr

(b) The emissions from each Group 005 source shall not exceed the following limits during any consecutive 12-month period:

- (1) 6.47 tons per year (TPY) of NO_x
- (2) 1.87 TPY of CO
- (3) 0.93 TPY of THC
- (4) 0.37 TPY of PM
- (5) 0.71 TPY of SO₂

[NOTE: Compliance with the requirement(s) specified in part (a)(2) of this streamlined permit condition assures compliance with the CO emission limit specified in 40 CFR §60.4205(c)]

**SECTION E. Source Group Restrictions.****Fuel Restriction(s).****# 003 [25 Pa. Code §127.512]****Operating permit terms and conditions.**

[Additional authority for this permit condition is also derived from Plan Approval No. 67-05005D]

In order to assure compliance with Condition #001(a), above, the permittee shall limit the sulfur content of the diesel/No. 2 fuel oil fired by each Group 005 source to 0.2% (by weight) or less. [NOTE: This fuel oil sulfur content restriction is superseded by the 0.0015% (by weight) fuel oil sulfur content restriction of Section E (Group 010), Condition #003.]

004 [25 Pa. Code §127.512]**Operating permit terms and conditions.**

The permittee shall operate each Group 005 source using diesel/No. 2 fuel oil only.

Operation Hours Restriction(s).**# 005 [25 Pa. Code §127.512]****Operating permit terms and conditions.**

[Additional authority for this permit condition is also derived from Plan Approval No. 67-05005D]

The permittee shall limit the annual operation of each Group 005 source to 1700 hours during any consecutive 12-month period.

II. TESTING REQUIREMENTS.

No additional testing requirements exist except as provided in other sections of this permit including Section B (Title V General Requirements).

III. MONITORING REQUIREMENTS.**# 006 [25 Pa. Code §127.511]****Monitoring and related recordkeeping and reporting requirements.**

The permittee shall calculate the monthly air emissions from each Group 005 source using AP-42 emission factors, manufacturer-supplied emission factors, material balance, performance (stack) test data, or other method(s) acceptable to the Department.

IV. RECORDKEEPING REQUIREMENTS.**# 007 [25 Pa. Code §127.511]****Monitoring and related recordkeeping and reporting requirements.**

The permittee shall demonstrate compliance with Condition #002(a), above, by maintaining records of the manufacturer emission data (or other method(s) approved by the Department) for each Group 005 source. The permittee shall make these records available to the Department upon its request.

008 [25 Pa. Code §127.511]**Monitoring and related recordkeeping and reporting requirements.**

(a) In demonstrating compliance with Condition #002(b), above, the permittee shall maintain records of each Group 005 source's monthly air emissions (and calculation methodology) referenced in Condition #006, above. Each air pollutant's monthly total shall be summed with the totals from the previous 11 months to determine the cumulative total for each consecutive 12-month period.

(b) The permittee shall retain these records for a minimum of five (5) years. The records shall be made available to the Department upon its request.

009 [25 Pa. Code §127.511]**Monitoring and related recordkeeping and reporting requirements.**

[Additional authority for this permit condition is also derived from Plan Approval No. 67-05005D]

(a) In demonstrating compliance with Condition #005, above, the permittee shall record the number of hours each Group 005 source operates on a monthly basis. Each monthly total shall be summed with the totals from the previous 11 months to determine the cumulative total for each consecutive 12-month period.

**SECTION E. Source Group Restrictions.**

(b) The permittee shall also keep records of the amount and type of fuel used in each Group 005 source on a monthly basis.

(c) The permittee shall retain these records for a minimum of five (5) years. The records shall be made available to the Department upon its request.

010 [25 Pa. Code §127.511]**Monitoring and related recordkeeping and reporting requirements.**

(a) The permittee shall maintain records of the fuel supplier's certification or laboratory analysis for each diesel/No. 2 fuel oil delivery received in order to demonstrate compliance with Condition #003, above. The fuel supplier's certification or laboratory analysis shall include, at a minimum, the weight percent sulfur.

(b) The permittee shall retain these records for a minimum of five (5) years and shall make them available to the Department upon its request.

011 [25 Pa. Code §129.100]**Compliance demonstration and recordkeeping requirements.**

(a) Pursuant to 25 Pa. Code §129.100(d), the permittee shall maintain a copy of each Group 005 engine manufacturer's specifications.

(b) Pursuant to 25 Pa. Code §129.100(d), the permittee shall maintain records of all maintenance activities to verify that each Group 005 engine has been maintained in accordance with the manufacturer's specifications.

(c) Pursuant to 25 Pa. Code §129.100(i), the permittee shall retain the records described in parts (a) and (b), above, for a minimum of five (5) years. The records shall be made available to the Department upon its request.

V. REPORTING REQUIREMENTS.

No additional reporting requirements exist except as provided in other sections of this permit including Section B (Title V General Requirements).

VI. WORK PRACTICE REQUIREMENTS.**# 012 [25 Pa. Code §129.97]****Presumptive RACT requirements, RACT emission limitations and petition for alternative compliance schedule.**

Pursuant to 25 Pa. Code §129.97(c)(5), the permittee shall operate and maintain each Group 005 engine in accordance with the manufacturer's specifications and with good operating practices for the control of NOx & VOC emissions.

[Compliance with this streamlined operating permit condition assures compliance with the presumptive RACT emission limit specified in 25 Pa. Code §129.93(c)(3)]

VII. ADDITIONAL REQUIREMENTS.**# 013 [25 Pa. Code §127.512]****Operating permit terms and conditions.**

In the event that 40 CFR Part 63, Subpart ZZZZ - National Emission Standards for Hazardous Air Pollutants for Stationary Reciprocating Internal Combustion Engines (MACT Subpart ZZZZ) is revised, the permittee shall comply with the revised version of MACT Subpart ZZZZ, and shall not be required to comply with any provisions in this operating permit designated as having MACT Subpart ZZZZ as their authority, to the extent that such operating permit provisions would be inconsistent with the applicable provisions of the revised MACT Subpart ZZZZ.

014 [40 CFR Part 63 NESHAPS for Source Categories §40 CFR 63.6590]**Subpart ZZZZ - National Emissions Standards for Hazardous Air Pollutants for Stationary Reciprocating Internal Combustion Engines****What parts of my plant does this subpart cover?**

Pursuant to 40 CFR §63.6590, 40 CFR Part 63, Subpart ZZZZ - National Emission Standards for Hazardous Air Pollutants for Stationary Reciprocating Internal Combustion Engines (MACT Subpart ZZZZ) applies to each affected source. Pursuant to 40 CFR §63.6590(a)(2)(ii), each Group 005 engine is an affected source that is defined as a new stationary RICE.

Pursuant to 40 CFR §63.6590(c)(6)&(7), each Group 005 engine must meet the requirements of MACT Subpart ZZZZ by

**SECTION E. Source Group Restrictions.**

meeting the requirements of 40 CFR Part 60, Subpart IIII (NSPS Subpart IIII), for compression ignition engines. No further requirements apply for such engines under 40 CFR Part 63. [NOTE: THE STATIONARY RICEs ARE EMERGENCY COMPRESSION IGNITION ENGINES SUBJECT TO THE REQUIREMENTS OF NSPS SUBPART IIII]

***** Permit Shield in Effect. *****

**SECTION E. Source Group Restrictions.**

Group Name: GROUP 006

Group Description: Material Handling

Sources included in this group

ID	Name
131	LIMESTONE MATERIAL HANDLING OPERATIONS
132	GYPSUM MATERIAL HANDLING OPERATIONS
133	WWTP LIME STORAGE SILO

I. RESTRICTIONS.**Emission Restriction(s).****# 001 [25 Pa. Code §127.512]****Operating permit terms and conditions.**

[Additional authority for this permit condition is also derived from 25 Pa. Code §127.1 and Plan Approval No. 67-05005E]

The total combined particulate matter emissions including fugitive emissions from the operation of the Group 006 sources shall not exceed 21.45 TPY of PM and 5.86 TPY of PM10 during any consecutive 12-month period.

II. TESTING REQUIREMENTS.

No additional testing requirements exist except as provided in other sections of this permit including Section B (Title V General Requirements).

III. MONITORING REQUIREMENTS.

No additional monitoring requirements exist except as provided in other sections of this permit including Section B (Title V General Requirements).

IV. RECORDKEEPING REQUIREMENTS.**# 002 [25 Pa. Code §127.511]****Monitoring and related recordkeeping and reporting requirements.**

[Additional authority for this permit condition is also derived from Plan Approval No. 67-05005E]

(a) In order to assure compliance with Condition #001, above, the permittee shall track and maintain accurate records of PM and PM10 emissions from the operation of the Group 006 sources on a monthly basis. The monthly total shall then be summed with the previous 11 monthly totals to determine the overall total for each consecutive 12-month period.

(b) The permittee shall report the emissions of PM and PM10 to the Department along with the submittal of the facility's annual air emissions report described in Condition #021(a) of Section C.

(c) The records shall also be retained at the facility for a period of five (5) years and shall be made available to the Department upon its request.

V. REPORTING REQUIREMENTS.

No additional reporting requirements exist except as provided in other sections of this permit including Section B (Title V General Requirements).

VI. WORK PRACTICE REQUIREMENTS.**# 003 [25 Pa. Code §127.512]****Operating permit terms and conditions.**

[Additional authority for this permit condition is also derived from 25 Pa. Code §127.1 and Plan Approval No. 67-05005E]

(a) The portion of the limestone reclaim conveyor (Facility ID #CNV-11) and the gypsum sludge stackout conveyors (Facility ID # CNV-50A & B) that pass over Wago Road shall be totally enclosed.

(b) All other conveyors associated with the Group 006 sources shall be fully enclosed or equipped with 3-sided covers (top

**SECTION E. Source Group Restrictions.**

and two sides) except those conveyors or portions of conveyors which are located underground or inside of a fully enclosed building.

004 [25 Pa. Code §127.512]**Operating permit terms and conditions.**

[Additional authority for this permit condition is also derived from 25 Pa. Code §127.1 and Plan Approval No. 67-05005E]

(a) An operable water truck shall be available at all times for use in the control of fugitive particulate matter emissions from roadways, stockpiles, etc. during operation of the Group 006 sources. The water truck shall be equipped with a pressurized water spray bar as well as with a pressurized spray gun or hose connection and shall be kept on-site and filled with water at all times except during the truck's transit to the refilling station. The permittee shall implement any effective winterization measures necessary to render this water truck capable of use under cold weather conditions.

(b) The permittee shall not operate non-vacuum type road sweepers on the roadways associated with the Group 006 sources.

(c) If, at any time, any component of the Group 006 sources is determined by the Department to be causing the emission of fugitive particulate matter in excess of the limitations specified in 25 Pa. Code Sections 123.1 or 123.2, or in excess of the level which the Department considers to be the "minimum attainable through the use of the best available technology", the permittee shall, upon notification by the Department, immediately install additional water sprays and/or take such other control measures as are necessary to reduce the fugitive particulate matter emissions to acceptable levels.

(d) The permittee shall establish and enforce a vehicle speed limit of 10 miles per hour on the roadways associated with the Group 006 sources. This speed limit shall be posted in highly visible locations along the respective roadways.

(e) All trucks loaded with limestone or gypsum that enter or exit the facility via a public roadway shall either be fully enclosed or have their loads tarped. This requirement shall be posted in highly visible locations within the facility.

(f) At least two (2) self-service truck tire washing stations shall be available for use in the area of the site in which the Group 006 sources are located. At least one (1) of the stations shall be located in the limestone truck unloading area. The permittee may suspend the use of these stations when weather conditions may result in hazardous conditions.

VII. ADDITIONAL REQUIREMENTS.

No additional requirements exist except as provided in other sections of this permit including Section B (Title V General Requirements).

***** Permit Shield in Effect. *****

**SECTION E. Source Group Restrictions.**

Group Name: GROUP 007

Group Description: Continuous Emissions Monitoring Systems (CEMSs)

Sources included in this group

ID	Name
031A	BRUNNER ISLAND UNIT 1
032	BRUNNER ISLAND UNIT 2
033A	BRUNNER ISLAND UNIT 3

I. RESTRICTIONS.

No additional requirements exist except as provided in other sections of this permit including Section B (Title V General Requirements).

II. TESTING REQUIREMENTS.

No additional testing requirements exist except as provided in other sections of this permit including Section B (Title V General Requirements).

III. MONITORING REQUIREMENTS.**# 001 [25 Pa. Code §127.511]****Monitoring and related recordkeeping and reporting requirements.**

Monitoring Requirements:

[Additional authority for this permit condition is derived from 40 CFR Part 75, 40 CFR §52.2020, and 25 Pa. Code §§139.4 and 139.101]

(a) Continuous Emissions Monitoring Requirements

(1) The following continuous emissions monitoring systems (CEMSs) must be installed, approved by the Department, operated and maintained in accordance with the requirements of 25 Pa. Code Chapter 139, Subchapter C (relating to requirements for source monitoring for stationary sources), and the "Submittal and Approval", "Record Keeping and Reporting", and "Quality Assurance" requirements of Revision No. 8 of the Department's Continuous Source Monitoring Manual, 274-0300-001.

For Unit Nos. 1, 2, and 3 (Source IDs 031A, 032, and 033A, respectively)

Pollutant	Measurement	Moisture	% O ₂	Ave. Period	Standard	Basis
NO _x	lb/mmBTU	N/A	N/A	30-day average rolling by 1 day	0.45 lb/mmBTU	hourly
SO ₂	lb/mmBTU	N/A	N/A	Daily average 2-day exception in any running 30-day period	4.0 lb/mmBTU	hourly
SO ₂	lb/mmBTU	N/A	N/A	3-hr average block	0.85 lb/mmBTU	hourly

NOTE: Compliance with any subsequently issued revisions to the Continuous Source Monitoring Manual will constitute compliance with the terms of this operating permit.

(b) Data Availability Standards

(1) All of the above CEMS shall, at a minimum, meet one of the following data availability requirements unless otherwise stipulated in this operating permit, a plan approval, Title 25, or an order issued under Section 4 of the Air Pollution Control Act:

**SECTION E. Source Group Restrictions.**

(i) In each calendar month, at least 90% of the time periods for which an emission standard or an operational parameter applies shall be valid as set forth in the Quality Assurance section of Revision No. 8 of the Department's Continuous Source Monitoring Manual, 274-0300-001 or,

(ii) In each calendar quarter, at least 95% of the hours shall be valid as set forth in the Quality Assurance section of Revision No. 8 of the Department's Continuous Source Monitoring Manual, 274-0300-001.

NOTE: Compliance with any subsequently issued revisions to the Continuous Source Monitoring Manual will constitute compliance with the terms of this operating permit.

(2) Emission Standard(s) To Which Data Availability Standard applies: Data availability standards apply to NO_x in lb/mmBTU per hour and SO₂ in lbs/mmBTU per hour.

(i) 30-day rolling averages for NO_x, and daily averages and 3-hr block averages for SO₂ shall be calculated in accordance with the Data Reduction Criteria in the Quality Assurance section of Revision No. 8 of the Department's Continuous Source Monitoring Manual, 274-0300-001.

(c) Certification and Testing Requirements**(1) Initial Application (Phase I)**

Upon promulgation of a monitoring requirement, a proposal containing information as listed in the Phase I section of the Department's Continuous Source Monitoring Manual for the proposed CEMs must be submitted to the Department 180 days prior to the initial startup of a new source and within 180 days of promulgation of a monitoring requirement for an existing source.

(2) Performance Testing (Phase II)

After approval of Phase I, the applicant shall proceed with purchasing, installation, and performance testing. The CEM Section must be advised, in writing, at least 45 days prior to Performance Specification Testing to provide the opportunity to observe and participate in all testing. A testing protocol describing all testing procedures and methodologies to be used must accompany the notice of testing. Schedule changes must be reported seven days prior to testing except that failed tests may be repeated immediately. Testing as listed in the Phase II section of the Department's Continuous Source Monitoring Manual must be completed for the CEMS(s) no later than 180 days after initial source startup and no later than 60 days after the source achieves normal process capacity. During testing, the source must be operated in a manner that is representative of normal operating conditions. All other notifications and performance specification testing must be conducted in accordance with the Department's Continuous Source Monitoring Manual.

(3) Final Approval (Phase III)

The final report of testing as listed in the Phase III section of the Department's Continuous Source Monitoring Manual must be submitted to the Department no later than 60 days after completion of the testing. The owner or operator of the source shall not be issued an operating permit until the CEMs have received Phase III approval, in writing, from the Department, when installation of a CEMs is made a condition of the plan approval. Until Phase III Department-approval is obtained, operation shall be covered solely under condition of a plan approval.

IV. RECORDKEEPING REQUIREMENTS.**# 002 [25 Pa. Code §127.511]****Monitoring and related recordkeeping and reporting requirements.**

Reporting Requirements:

[Additional authority for this permit condition is derived from 40 CFR Part 75, 40 CFR §52.2020, and 25 Pa. Code §§139.101(5) and 139.101(12)]

1. The permittee shall comply with the recordkeeping requirements established in 25 Pa. Code Chapter 139, Subchapter C (relating to requirements for source monitoring for stationary sources), the "Record Keeping and Reporting" requirements in the Department's Continuous Source Monitoring Manual, Revision No. 8, 274-0300-001.

2. Records shall be retained for at least 5 years and shall be made available to the Department upon its request.

**SECTION E. Source Group Restrictions.**

NOTE: Compliance with any subsequently issued revision to the Continuous Source Monitoring Manual will constitute compliance with the terms of this operating permit.

V. REPORTING REQUIREMENTS.**# 003 [25 Pa. Code §127.511]****Monitoring and related recordkeeping and reporting requirements.**

[Additional authority for this permit condition is derived from 40 CFR Part 75, 40 CFR §52.2020, and 25 Pa. Code §§139.101(1)(iv), 139.101(10) & 139.101(12)]

1. The permittee shall submit quarterly reports of continuous emission monitoring to the Department in accordance with the requirements established in 25 Pa. Code Chapter 139, Subchapter C (relating to requirements for source monitoring for stationary sources), the "Record Keeping and Reporting" requirements as established in the Department's Continuous Source Monitoring Manual, Revision No. 8, 274-0300-001.
2. The permittee shall report emissions for all periods of unit operation, including startup, shutdown and malfunction.
3. Initial quarterly reports following system certification shall be submitted to the Department within 35 days following the date upon which the Department notifies the owner or operator, in writing, of the approval of the continuous source monitoring system for use in determining compliance with applicable emission standards.
4. Subsequent quarterly reports shall be submitted to the Department within 30 days after the end of each calendar quarter.
5. Failure to submit required reports of continuous emission monitoring within the time periods specified in this operating permit condition shall constitute violations of this operating permit, unless approved in advance by the Department in writing.

NOTE: Compliance with any subsequently issued revision to the Continuous Source Monitoring Manual will constitute compliance with the terms of this operating permit.

VI. WORK PRACTICE REQUIREMENTS.

No additional work practice requirements exist except as provided in other sections of this permit including Section B (Title V General Requirements).

VII. ADDITIONAL REQUIREMENTS.**# 004 [25 Pa. Code §127.512]****Operating permit terms and conditions.**

Quality Assurance Requirements:

[Additional authority for this permit condition is derived from 40 CFR Part 75, 40 CFR §52.2020, and 25 Pa. Code §§139.101(1)(iv), 139.101(2), 139.101(3), 139.101(4), 139.101(6), 139.101(7), 139.101(8), 139.101(12), 139.101(14), and 139.101(15)]

Continuous Emission Monitoring Systems and components must be operated and maintained in accordance with the requirements established in 25 Pa. Code Chapter 139, Subchapter C (relating to requirements for source monitoring for stationary sources), the "Quality Assurance" requirements in the Department's Continuous Source Monitoring Manual, Revision No. 8, 274-0300-001.

NOTE: Compliance with any subsequently issued revision to the Continuous Source Monitoring Manual will constitute compliance with the terms of this operating permit.

*** **Permit Shield in Effect.** ***

**SECTION E. Source Group Restrictions.**

Group Name: GROUP 008

Group Description: Cross-State Air Pollution Rule (CSAPR) Requirements

Sources included in this group

ID	Name
031A	BRUNNER ISLAND UNIT 1
032	BRUNNER ISLAND UNIT 2
033A	BRUNNER ISLAND UNIT 3

I. RESTRICTIONS.

No additional requirements exist except as provided in other sections of this permit including Section B (Title V General Requirements).

II. TESTING REQUIREMENTS.

No additional testing requirements exist except as provided in other sections of this permit including Section B (Title V General Requirements).

III. MONITORING REQUIREMENTS.**# 001 [25 Pa. Code §127.511]****Monitoring and related recordkeeping and reporting requirements.**

Description of Transport Rule (TR) Monitoring Provisions

The TR subject units, and the unit-specific monitoring provisions at this source, are identified below. These units are subject to the requirements for the TR NO_x Annual Trading Program, TR NO_x Ozone Season Trading Program and TR SO₂ Group 1 Trading Program.

SOURCE ID 031A - UNIT 1; SOURCE ID 032 - UNIT 2; AND SOURCE ID 033A - UNIT 3:

SO₂: Excepted monitoring system requirements for gas-and oil-fired units pursuant to 40 CFR Part 75, Appendix D

NO_x: Continuous emission monitoring system or systems (CEMS) requirements pursuant to 40 CFR Part 75, Subpart B (for NO_x monitoring) and 40 CFR Part 75, Subpart H (for NO_x monitoring)

HEAT INPUT: Excepted monitoring system requirements for gas-and oil-fired units pursuant to 40 CFR Part 75, Appendix D

1. The above description of the monitoring used by a unit does not change, create an exemption from, or otherwise affect the monitoring, recordkeeping, and reporting requirements applicable to the unit under 40 CFR §§97.430 through 97.435 (TR NO_x Annual Trading Program), 40 CFR §§97.630 through 97.635 (CSAPR SO₂ Group 1 Trading Program), and 40 CFR §§97.830 through 97.835 (CSAPR NO_x Ozone Season Group 2 Trading Program). The monitoring, recordkeeping and reporting requirements applicable to each unit are included below in the standard conditions for the applicable TR trading programs.

2. Owners and operators must submit to the Administrator a monitoring plan for each unit in accordance with 40 CFR §§75.53, 75.62 and 75.73, as applicable. The monitoring plan for each unit is available at U.S. EPA's website at <http://www.epa.gov/airmarkets/emissions/monitoringplans.html>.

3. Owners and operators that want to use an alternative monitoring system must submit to the Administrator a petition requesting approval of the alternative monitoring system in accordance with 40 CFR Part 75, Subpart E and 40 CFR §§75.66 and 97.435 (TR NO_x Annual Trading Program), 40 CFR §97.635 (CSAPR SO₂ Group 1 Trading Program), and 40 CFR §97.835 (CSAPR NO_x Ozone Season Group 2 Trading Program). The Administrator's response approving or disapproving any petition for an alternative monitoring system is available on U.S. EPA's website at <http://www.epa.gov/airmarkets/emissions/petitions.html>.

4. Owners and operators that want to use an alternative to any monitoring, recordkeeping, or reporting requirement under 40 CFR §§97.430 through 97.434 (TR NO_x Annual Trading Program), 40 CFR §§97.630 through 97.634 (CSAPR SO₂ Group 1 Trading Program), and 40 CFR §§97.830 through 97.834 (CSAPR NO_x Ozone Season Group 2 Trading Program), must submit to the Administrator a petition requesting approval of the alternative in accordance with 40 CFR §§75.66 and

**SECTION E. Source Group Restrictions.**

97.435 (TR NOx Annual Trading Program), 40 CFR §97.635 (CSAPR SO2 Group 1 Trading Program), and 40 CFR §97.835 (CSAPR NOx Ozone Season Group 2 Trading Program). The Administrator's response approving or disapproving any petition for an alternative to a monitoring, recordkeeping, or reporting requirement is available on U.S. EPA's website at <http://www.epa.gov/airmarkets/emissions/petitions.html>.

5. The descriptions of monitoring applicable to the unit included above meet the requirement of 40 CFR §§97.430 through 97.434 (TR NOx Annual Trading Program), 40 CFR §§97.630 through 97.634 (CSAPR SO2 Group 1 Trading Program), and 40 CFR §§97.830 through 97.834 (CSAPR NOx Ozone Season Group 2 Trading Program), and therefore minor operating permit modification procedures, in accordance with 40 CFR §70.7(e)(2)(i)(B) or 40 CFR §71.7(e)(1)(i)(B), may be used to add to or change this unit's monitoring system description.

IV. RECORDKEEPING REQUIREMENTS.

No additional record keeping requirements exist except as provided in other sections of this permit including Section B (Title V General Requirements).

V. REPORTING REQUIREMENTS.

No additional reporting requirements exist except as provided in other sections of this permit including Section B (Title V General Requirements).

VI. WORK PRACTICE REQUIREMENTS.

No additional work practice requirements exist except as provided in other sections of this permit including Section B (Title V General Requirements).

VII. ADDITIONAL REQUIREMENTS.**# 002 [25 Pa. Code §127.512]****Operating permit terms and conditions.**

Transport Rule (TR) NOx Annual Trading Program requirements (40 CFR §97.406)

(a) Designated representative requirements.

The owners and operators shall comply with the requirement to have a designated representative, and may have an alternate designated representative, in accordance with 40 CFR §§97.413 through 97.418.

(b) Emissions monitoring, reporting, and recordkeeping requirements.

(1) The owners and operators, and the designated representative, of each TR NOx Annual source and each TR NOx Annual unit at the source shall comply with the monitoring, reporting, and recordkeeping requirements of 40 CFR §§97.430 (general requirements, including installation, certification, and data accounting, compliance deadlines, reporting data, prohibitions, and long-term cold storage), 97.431 (initial monitoring system certification and recertification procedures), 97.432 (monitoring system out-of-control periods), 97.433 (notifications concerning monitoring), 97.434 (recordkeeping and reporting, including monitoring plans, certification applications, quarterly reports, and compliance certification), and 97.435 (petitions for alternatives to monitoring, recordkeeping, or reporting requirements).

(2) The emissions data determined in accordance with 40 CFR §§97.430 through 97.435 shall be used to calculate allocations of TR NOx Annual allowances under 40 CFR §§97.411 (a)(2) and (b) and 97.412 and to determine compliance with the TR NOx Annual emissions limitation and assurance provisions under paragraph (c), below, provided that, for each monitoring location from which mass emissions are reported, the mass emissions amount used in calculating such allocations and determining such compliance shall be the mass emissions amount for the monitoring location determined in accordance with 40 CFR §§97.430 through 97.435 and rounded to the nearest ton, with any fraction of a ton less than 0.50 being deemed to be zero.

(c) NOx emissions requirements.

(1) TR NOx Annual emissions limitation.

**SECTION E. Source Group Restrictions.**

(i) As of the allowance transfer deadline for a control period in a given year, the owners and operators of each TR NOx Annual source and each TR NOx Annual unit at the source shall hold, in the source's compliance account, TR NOx Annual allowances available for deduction for such control period under 40 CFR §97.424(a) in an amount not less than the tons of total NOx emissions for such control period from all TR NOx Annual units at the source.

(ii) If total NOx emissions during a control period in a given year from the TR NOx Annual units at a TR NOx Annual source are in excess of the TR NOx Annual emissions limitation set forth in paragraph (c)(1)(i), above, then:

(A) The owners and operators of the source and each TR NOx Annual unit at the source shall hold the TR NOx Annual allowances required for deduction under 40 CFR §97.424(d); and

(B) The owners and operators of the source and each TR NOx Annual unit at the source shall pay any fine, penalty, or assessment or comply with any other remedy imposed, for the same violations, under the Clean Air Act, and each ton of such excess emissions and each day of such control period shall constitute a separate violation of 40 CFR Part 97, Subpart AAAAA and the Clean Air Act.

(2) TR NOx Annual assurance provisions.

(i) If total NOx emissions during a control period in a given year from all TR NOx Annual units at TR NOx Annual sources in the state exceed the state assurance level, then the owners and operators of such sources and units in each group of one or more sources and units having a common designated representative for such control period, where the common designated representative's share of such NOx emissions during such control period exceeds the common designated representative's assurance level for the state and such control period, shall hold (in the assurance account established for the owners and operators of such group) TR NOx Annual allowances available for deduction for such control period under 40 CFR §97.425(a) in an amount equal to two times the product (rounded to the nearest whole number), as determined by the Administrator in accordance with 40 CFR §97.425(b), of multiplying:

(A) The quotient of the amount by which the common designated representative's share of such NOx emissions exceeds the common designated representative's assurance level divided by the sum of the amounts, determined for all common designated representatives for such sources and units in the state for such control period, by which each common designated representative's share of such NOx emissions exceeds the respective common designated representative's assurance level; and

(B) The amount by which total NOx emissions from all TR NOx Annual units at TR NOx Annual sources in the state for such control period exceed the state assurance level.

(ii) The owners and operators shall hold the TR NOx Annual allowances required under paragraph (c)(2)(i) above, as of midnight of November 1 (if it is a business day), or midnight of the first business day thereafter (if November 1 is not a business day), immediately after such control period.

(iii) Total NOx emissions from all TR NOx Annual units at TR NOx Annual sources in the State during a control period in a given year exceed the state assurance level if such total NOx emissions exceed the sum, for such control period, of the state NOx Annual trading budget under 40 CFR §97.410(a) and the state's variability limit under 40 CFR §97.410(b).

(iv) It shall not be a violation of 40 CFR Part 97, Subpart AAAAA or of the Clean Air Act if total NOx emissions from all TR NOx Annual units at TR NOx Annual sources in the State during a control period exceed the state assurance level or if a common designated representative's share of total NOx emissions from the TR NOx Annual units at TR NOx Annual sources in the state during a control period exceeds the common designated representative's assurance level.

(v) To the extent the owners and operators fail to hold TR NOx Annual allowances for a control period in a given year in accordance with paragraphs (c)(2)(i) through (iii), above,

(A) The owners and operators shall pay any fine, penalty, or assessment or comply with any other remedy imposed under the Clean Air Act; and

(B) Each TR NOx Annual allowance that the owners and operators fail to hold for such control period in accordance with paragraphs (c)(2)(i) through (iii), above, and each day of such control period shall constitute a separate violation of 40 CFR

**SECTION E. Source Group Restrictions.**

Part 97, Subpart AAAAA and the Clean Air Act.

(3) Compliance periods.

(i) A TR NO_x Annual unit shall be subject to the requirements under paragraph (c)(1), above, for the control period starting on the later of January 1, 2015, or the deadline for meeting the unit's monitor certification requirements under 40 CFR §97.430(b) and for each control period thereafter.

(ii) A TR NO_x Annual unit shall be subject to the requirements under paragraph (c)(2), above, for the control period starting on the later of January 1, 2017 or the deadline for meeting the unit's monitor certification requirements under 40 CFR §97.430(b) and for each control period thereafter.

(4) Vintage of allowances held for compliance.

(i) A TR NO_x Annual allowance held for compliance with the requirements under paragraph (c)(1)(i), above, for a control period in a given year must be a TR NO_x Annual allowance that was allocated for such control period or a control period in a prior year.

(ii) A TR NO_x Annual allowance held for compliance with the requirements under paragraphs (c)(1)(ii)(A) and (2)(i) through (iii), above, for a control period in a given year must be a TR NO_x Annual allowance that was allocated for a control period in a prior year or the control period in the given year or in the immediately following year.

(5) Allowance Management System requirements. Each TR NO_x Annual allowance shall be held in, deducted from, or transferred into, out of, or between Allowance Management System accounts in accordance with 40 CFR Part 97, Subpart AAAAA.

(6) Limited authorization. A TR NO_x Annual allowance is a limited authorization to emit one ton of NO_x during the control period in one year. Such authorization is limited in its use and duration as follows:

(i) Such authorization shall only be used in accordance with the TR NO_x Annual Trading Program; and

(ii) Notwithstanding any other provision of 40 CFR Part 97, the Administrator has the authority to terminate or limit the use and duration of such authorization to the extent the Administrator determines is necessary or appropriate to implement any provision of the Clean Air Act.

(7) Property right. A TR NO_x Annual allowance does not constitute a property right.

(d) Title V permit revision requirements.

(1) No Title V permit revision shall be required for any allocation, holding, deduction, or transfer of TR NO_x Annual allowances in accordance with 40 CFR Part 97, Subpart AAAAA.

(2) This permit incorporates the TR emissions monitoring, recordkeeping and reporting requirements pursuant to 40 CFR §§97.430 through 97.435, and the requirements for a continuous emission monitoring system (pursuant to 40 CFR Part 75, Subparts B and H), an excepted monitoring system (pursuant to 40 CFR Part 75, Appendices D and E), a low mass emissions excepted monitoring methodology (pursuant to 40 CFR §75.19), and an alternative monitoring system (pursuant to 40 CFR Part 75, Subpart E). Therefore, the Description of TR Monitoring Provisions table for units identified in this permit may be added to, or changed, in this Title V permit using minor permit modification procedures in accordance with 40 CFR §§97.406(d)(2) and 70.7(e)(2)(i)(B) or 71.7(e)(1)(i)(B).

(e) Additional recordkeeping and reporting requirements.

(1) Unless otherwise provided, the owners and operators of each TR NO_x Annual source and each TR NO_x Annual unit at the source shall keep on-site at the source each of the following documents (in hardcopy or electronic format) for a period of 5 years from the date the document is created. This period may be extended for cause, at any time before the end of 5 years, in writing by the Administrator.

**SECTION E. Source Group Restrictions.**

(i) The certificate of representation under 40 CFR §97.416 for the designated representative for the source and each TR NOx Annual unit at the source and all documents that demonstrate the truth of the statements in the certificate of representation; provided that the certificate and documents shall be retained on site at the source beyond such 5-year period until such certificate of representation and documents are superseded because of the submission of a new certificate of representation under 40 CFR §97.416 changing the designated representative.

(ii) All emissions monitoring information, in accordance with 40 CFR Part 97, Subpart AAAAA.

(iii) Copies of all reports, compliance certifications, and other submissions and all records made or required under, or to demonstrate compliance with the requirements of, the TR NOx Annual Trading Program.

(2) The designated representative of a TR NOx Annual source and each TR NOx Annual unit at the source shall make all submissions required under the TR NOx Annual Trading Program, except as provided in 40 CFR §97.418. This requirement does not change, create an exemption from, or otherwise affect the responsible official submission requirements under a Title V operating permit program in 40 CFR Parts 70 and 71.

(f) Liability.

(1) Any provision of the TR NOx Annual Trading Program that applies to a TR NOx Annual source or the designated representative of a TR NOx Annual source shall also apply to the owners and operators of such source and of the TR NOx Annual units at the source.

(2) Any provision of the TR NOx Annual Trading Program that applies to a TR NOx Annual unit or the designated representative of a TR NOx Annual unit shall also apply to the owners and operators of such unit.

(g) Effect on other authorities.

No provision of the TR NOx Annual Trading Program or exemption under 40 CFR §97.405 shall be construed as exempting or excluding the owners and operators, and the designated representative, of a TR NOx Annual source or TR NOx Annual unit from compliance with any other provision of the applicable, approved state implementation plan, a federally enforceable permit, or the Clean Air Act.

Transport Rule (TR) NOx Ozone Season Group 2 Trading Program Requirements (40 CFR §97.806)

(a) Designated representative requirements.

The owners and operators shall comply with the requirement to have a designated representative, and may have an alternate designated representative, in accordance with 40 §CFR 97.813 through 97.818.

(b) Emissions monitoring, reporting, and recordkeeping requirements.

(1) The owners and operators, and the designated representative, of each TR NOx Ozone Season Group 2 source and each TR NOx Ozone Season Group 2 unit at the source shall comply with the monitoring, reporting, and recordkeeping requirements of 40 CFR §§97.830 (general requirements, including installation, certification, and data accounting, compliance deadlines, reporting data, prohibitions, and long-term cold storage), 97.831 (initial monitoring system certification and recertification procedures), 97.832 (monitoring system out-of-control periods), 97.833 (notifications concerning monitoring), 97.834 (recordkeeping and reporting, including monitoring plans, certification applications, quarterly reports, and compliance certification), and 97.835 (petitions for alternatives to monitoring, recordkeeping, or reporting requirements).

(2) The emissions data determined in accordance with 40 CFR §§97.830 through 97.835 shall be used to calculate allocations of TR NOx Ozone Season Group 2 allowances under 40 CFR §§97.811(a)(2) and (b) and 97.812 and to determine compliance with the TR NOx Ozone Season Group 2 emissions limitation and assurance provisions under paragraph (c), below, provided that, for each monitoring location from which mass emissions are reported, the mass emissions amount used in calculating such allocations and determining such compliance shall be the mass emissions

**SECTION E. Source Group Restrictions.**

amount for the monitoring location determined in accordance with 40 CFR §§97.830 through 97.835 and rounded to the nearest ton, with any fraction of a ton less than 0.50 being deemed to be zero.

(c) NO_x emissions requirements.

(1) TR NO_x Ozone Season Group 2 emissions limitation.

(i) As of the allowance transfer deadline for a control period in a given year, the owners and operators of each TR NO_x Ozone Season Group 2 source and each TR NO_x Ozone Season Group 2 unit at the source shall hold, in the source's compliance account, TR NO_x Ozone Season allowances available for deduction for such control period under 40 CFR §97.824(a) in an amount not less than the tons of total NO_x emissions for such control period from all TR NO_x Ozone Season Group 2 units at the source.

(ii) If total NO_x emissions during a control period in a given year from the TR NO_x Ozone Season Group 2 units at a TR NO_x Ozone Season Group 2 source are in excess of the TR NO_x Ozone Season Group 2 emissions limitation set forth in paragraph (c)(1)(i), above, then:

(A) The owners and operators of the source and each TR NO_x Ozone Season Group 2 unit at the source shall hold the TR NO_x Ozone Season Group 2 allowances required for deduction under 40 CFR §97.824(d); and

(B) The owners and operators of the source and each TR NO_x Ozone Season Group 2 unit at the source shall pay any fine, penalty, or assessment or comply with any other remedy imposed, for the same violations, under the Clean Air Act, and each ton of such excess emissions and each day of such control period shall constitute a separate violation of 40 CFR Part 97, Subpart EEEEE and the Clean Air Act.

(2) TR NO_x Ozone Season Group 2 assurance provisions.

(i) If total NO_x emissions during a control period in a given year from all TR NO_x Ozone Season Group 2 units at TR NO_x Ozone Season Group 2 sources in the state exceed the state assurance level, then the owners and operators of such sources and units in each group of one or more sources and units having a common designated representative for such control period, where the common designated representative's share of such NO_x emissions during such control period exceeds the common designated representative's assurance level for the state and such control period, shall hold (in the assurance account established for the owners and operators of such group) TR NO_x Ozone Season Group 2 allowances available for deduction for such control period under 40 CFR §97.825(a) in an amount equal to two times the product (rounded to the nearest whole number), as determined by the Administrator in accordance with 40 CFR §97.825(b), of multiplying:

(A) The quotient of the amount by which the common designated representative's share of such NO_x emissions exceeds the common designated representative's assurance level divided by the sum of the amounts, determined for all common designated representatives for such sources and units in the state for such control period, by which each common designated representative's share of such NO_x emissions exceeds the respective common designated representative's assurance level; and

(B) The amount by which total NO_x emissions from all TR NO_x Ozone Season Group 2 units at TR NO_x Ozone Season Group 2 sources in the state for such control period exceed the state assurance level.

(ii) The owners and operators shall hold the TR NO_x Ozone Season Group 2 allowances required under paragraph (c)(2)(i), above, as of midnight of November 1 (if it is a business day), or midnight of the first business day thereafter (if November 1 is not a business day), immediately after such control period.

(iii) Total NO_x emissions from all TR NO_x Ozone Season Group 2 units at TR NO_x Ozone Season Group 2 sources in the state during a control period in a given year exceed the state assurance level if such total NO_x emissions exceed the sum, for such control period, of the State NO_x Ozone Season Group 2 trading budget under 40 CFR §97.810(a) and the state's variability limit under 40 CFR §97.810(b).

(iv) It shall not be a violation of 40 CFR Part 97, Subpart EEEEE or of the Clean Air Act if total NO_x emissions from all TR NO_x Ozone Season Group 2 units at TR NO_x Ozone Season Group 2 sources in the state during a control period exceed the

**SECTION E. Source Group Restrictions.**

state assurance level or if a common designated representative's share of total NO_x emissions from the TR NO_x Ozone Season Group 2 units at TR NO_x Ozone Season Group 2 sources in the state during a control period exceeds the common designated representative's assurance level.

(v) To the extent the owners and operators fail to hold TR NO_x Ozone Season Group 2 allowances for a control period in a given year in accordance with paragraphs (c)(2)(i) through (iii), above:

(A) The owners and operators shall pay any fine, penalty, or assessment or comply with any other remedy imposed under the Clean Air Act; and

(B) Each TR NO_x Ozone Season Group 2 allowance that the owners and operators fail to hold for such control period in accordance with paragraphs (c)(2)(i) through (iii), above, and each day of such control period shall constitute a separate violation of 40 CFR Part 97, Subpart EEEEE and the Clean Air Act.

(3) Compliance periods.

(i) A TR NO_x Ozone Season Group 2 unit shall be subject to the requirements under paragraph (c)(1), above, for the control period starting on the later of May 1, 2015 or the deadline for meeting the unit's monitor certification requirements under 40 CFR §97.830(b) and for each control period thereafter.

(ii) A TR NO_x Ozone Season Group 2 unit shall be subject to the requirements under paragraph (c)(2), above, for the control period starting on the later of May 1, 2017 or the deadline for meeting the unit's monitor certification requirements under 40 CFR §97.830(b) and for each control period thereafter.

(4) Vintage of allowances held for compliance.

(i) A TR NO_x Ozone Season Group 2 allowance held for compliance with the requirements under paragraph (c)(1)(i), above, for a control period in a given year must be a TR NO_x Ozone Season Group 2 allowance that was allocated for such control period or a control period in a prior year.

(ii) A TR NO_x Ozone Season Group 2 allowance held for compliance with the requirements under paragraphs (c)(1)(ii)(A) and (2)(i) through (iii), above, for a control period in a given year must be a TR NO_x Ozone Season Group 2 allowance that was allocated for a control period in a prior year or the control period in the given year or in the immediately following year.

(5) Allowance Management System requirements. Each TR NO_x Ozone Season Group 2 allowance shall be held in, deducted from, or transferred into, out of, or between Allowance Management System accounts in accordance with 40 CFR Part 97, Subpart EEEEE.

(6) Limited authorization. A TR NO_x Ozone Season Group 2 allowance is a limited authorization to emit one ton of NO_x during the control period in one year. Such authorization is limited in its use and duration as follows:

(i) Such authorization shall only be used in accordance with the TR NO_x Ozone Season Group 2 Trading Program; and

(ii) Notwithstanding any other provision of 40 CFR Part 97, Subpart EEEEE, the Administrator has the authority to terminate or limit the use and duration of such authorization to the extent the Administrator determines is necessary or appropriate to implement any provision of the Clean Air Act.

(7) Property right. A TR NO_x Ozone Season Group 2 allowance does not constitute a property right.

(d) Title V permit revision requirements.

(1) No Title V permit revision shall be required for any allocation, holding, deduction, or transfer of TR NO_x Ozone Season Group 2 allowances in accordance with 40 CFR Part 97, Subpart EEEEE.

(2) This permit incorporates the TR emissions monitoring, recordkeeping and reporting requirements pursuant to 40 CFR §§97.830 through 97.835, and the requirements for a continuous emission monitoring system (pursuant to 40 CFR Part 75, Subparts B and H), an excepted monitoring system (pursuant to 40 CFR Part 75, Appendices D and E), a low mass

**SECTION E. Source Group Restrictions.**

emissions excepted monitoring methodology (pursuant to 40 CFR §75.19), and an alternative monitoring system (pursuant to 40 CFR Part 75, Subpart E). Therefore, the Description of TR Monitoring Provisions table for units identified in this permit may be added to, or changed, in this Title V permit using minor permit modification procedures in accordance with 40 CFR §§97.806(d)(2) and 70.7(e)(2)(i)(B) or 71.7(e)(1)(i)(B).

(e) Additional recordkeeping and reporting requirements.

(1) Unless otherwise provided, the owners and operators of each TR NOx Ozone Season Group 2 source and each TR NOx Ozone Season Group 2 unit at the source shall keep on site at the source each of the following documents (in hardcopy or electronic format) for a period of 5 years from the date the document is created. This period may be extended for cause, at any time before the end of 5 years, in writing by the Administrator.

(i) The certificate of representation under 40 CFR §97.816 for the designated representative for the source and each TR NOx Ozone Season Group 2 unit at the source and all documents that demonstrate the truth of the statements in the certificate of representation; provided that the certificate and documents shall be retained on site at the source beyond such 5-year period until such certificate of representation and documents are superseded because of the submission of a new certificate of representation under 40 CFR §97.816 changing the designated representative.

(ii) All emissions monitoring information, in accordance with 40 CFR Part 97, Subpart EEEEE.

(iii) Copies of all reports, compliance certifications, and other submissions and all records made or required under, or to demonstrate compliance with the requirements of, the TR NOx Ozone Season Group 2 Trading Program.

(2) The designated representative of a TR NOx Ozone Season Group 2 source and each TR NOx Ozone Season Group 2 unit at the source shall make all submissions required under the TR NOx Ozone Season Group 2 Trading Program, except as provided in 40 CFR §97.818. This requirement does not change, create an exemption from, or otherwise affect the responsible official submission requirements under a Title V operating permit program in 40 CFR Parts 70 and 71.

(f) Liability.

(1) Any provision of the TR NOx Ozone Season Group 2 Trading Program that applies to a TR NOx Ozone Season Group 2 source or the designated representative of a TR NOx Ozone Season Group 2 source shall also apply to the owners and operators of such source and of the TR NOx Ozone Season Group 2 units at the source.

(2) Any provision of the TR NOx Ozone Season Group 2 Trading Program that applies to a TR NOx Ozone Season Group 2 unit or the designated representative of a TR NOx Ozone Season Group 2 unit shall also apply to the owners and operators of such unit.

(g) Effect on other authorities.

No provision of the TR NOx Ozone Season Group 2 Trading Program or exemption under 40 CFR §97.805 shall be construed as exempting or excluding the owners and operators, and the designated representative, of a TR NOx Ozone Season Group 2 source or TR NOx Ozone Season Group 2 unit from compliance with any other provision of the applicable, approved state implementation plan, a federally enforceable permit, or the Clean Air Act.

TR SO₂ Group 1 Trading Program requirements (40 CFR §97.606)**(a) Designated representative requirements.**

The owners and operators shall comply with the requirement to have a designated representative, and may have an alternate designated representative, in accordance with 40 CFR §§97.613 through 97.618.

(b) Emissions monitoring, reporting, and recordkeeping requirements.

(1) The owners and operators, and the designated representative, of each TR SO₂ Group 1 source and each TR SO₂

**SECTION E. Source Group Restrictions.**

Group 1 unit at the source shall comply with the monitoring, reporting, and recordkeeping requirements of 40 CFR §§97.630 (general requirements, including installation, certification, and data accounting, compliance deadlines, reporting data, prohibitions, and long-term cold storage), 97.631 (initial monitoring system certification and recertification procedures), 97.632 (monitoring system out-of-control periods), 97.633 (notifications concerning monitoring), 97.634 (recordkeeping and reporting, including monitoring plans, certification applications, quarterly reports, and compliance certification), and 97.635 (petitions for alternatives to monitoring, recordkeeping, or reporting requirements).

(2) The emissions data determined in accordance with 40 CFR §§97.630 through 97.635 shall be used to calculate allocations of TR SO₂ Group 1 allowances under 40 CFR §§97.611(a)(2) and (b) and 97.612 and to determine compliance with the TR SO₂ Group 1 emissions limitation and assurance provisions under paragraph (c), below, provided that, for each monitoring location from which mass emissions are reported, the mass emissions amount used in calculating such allocations and determining such compliance shall be the mass emissions amount for the monitoring location determined in accordance with 40 CFR §§97.630 through 97.635 and rounded to the nearest ton, with any fraction of a ton less than 0.50 being deemed to be zero.

(c) SO₂ emissions requirements.

(1) TR SO₂ Group 1 emissions limitation.

(i) As of the allowance transfer deadline for a control period in a given year, the owners and operators of each TR SO₂ Group 1 source and each TR SO₂ Group 1 unit at the source shall hold, in the source's compliance account, TR SO₂ Group 1 allowances available for deduction for such control period under 40 CFR §97.624(a) in an amount not less than the tons of total SO₂ emissions for such control period from all TR SO₂ Group 1 units at the source.

(ii) If total SO₂ emissions during a control period in a given year from the TR SO₂ Group 1 units at a TR SO₂ Group 1 source are in excess of the TR SO₂ Group 1 emissions limitation set forth in paragraph (c)(1)(i), above, then:

(A) The owners and operators of the source and each TR SO₂ Group 1 unit at the source shall hold the TR SO₂ Group 1 allowances required for deduction under 40 CFR §97.624(d); and

(B) The owners and operators of the source and each TR SO₂ Group 1 unit at the source shall pay any fine, penalty, or assessment or comply with any other remedy imposed, for the same violations, under the Clean Air Act, and each ton of such excess emissions and each day of such control period shall constitute a separate violation 40 CFR Part 97, Subpart CCCCC and the Clean Air Act.

(2) TR SO₂ Group 1 assurance provisions.

(i) If total SO₂ emissions during a control period in a given year from all TR SO₂ Group 1 units at TR SO₂ Group 1 sources in the state exceed the state assurance level, then the owners and operators of such sources and units in each group of one or more sources and units having a common designated representative for such control period, where the common designated representative's share of such SO₂ emissions during such control period exceeds the common designated representative's assurance level for the state and such control period, shall hold (in the assurance account established for the owners and operators of such group) TR SO₂ Group 1 allowances available for deduction for such control period under 40 CFR §97.625(a) in an amount equal to two times the product (rounded to the nearest whole number), as determined by the Administrator in accordance with 40 CFR §97.625(b), of multiplying:

(A) The quotient of the amount by which the common designated representative's share of such SO₂ emissions exceeds the common designated representative's assurance level divided by the sum of the amounts, determined for all common designated representatives for such sources and units in the state for such control period, by which each common designated representative's share of such SO₂ emissions exceeds the respective common designated representative's assurance level; and

(B) The amount by which total SO₂ emissions from all TR SO₂ Group 1 units at TR SO₂ Group 1 sources in the state for such control period exceed the state assurance level.

(ii) The owners and operators shall hold the TR SO₂ Group 1 allowances required under paragraph (c)(2)(i), above, as of midnight of November 1 (if it is a business day), or midnight of the first business day thereafter (if November 1 is not a

**SECTION E. Source Group Restrictions.**

business day), immediately after such control period.

(iii) Total SO₂ emissions from all TR SO₂ Group 1 units at TR SO₂ Group 1 sources in the state during a control period in a given year exceed the state assurance level if such total SO₂ emissions exceed the sum, for such control period, of the state SO₂ Group 1 trading budget under 40 CFR §97.610(a) and the state's variability limit under 40 CFR §97.610(b).

(iv) It shall not be a violation of 40 CFR Part 97, Subpart CCCCC or of the Clean Air Act if total SO₂ emissions from all TR SO₂ Group 1 units at TR SO₂ Group 1 sources in the state during a control period exceed the state assurance level or if a common designated representative's share of total SO₂ emissions from the TR SO₂ Group 1 units at TR SO₂ Group 1 sources in the state during a control period exceeds the common designated representative's assurance level.

(v) To the extent the owners and operators fail to hold TR SO₂ Group 1 allowances for a control period in a given year in accordance with paragraphs (c)(2)(i) through (iii), above:

(A) The owners and operators shall pay any fine, penalty, or assessment or comply with any other remedy imposed under the Clean Air Act; and

(B) Each TR SO₂ Group 1 allowance that the owners and operators fail to hold for such control period in accordance with paragraphs (c)(2)(i) through (iii), above and each day of such control period shall constitute a separate violation of 40 CFR Part 97, Subpart CCCCC and the Clean Air Act.

(3) Compliance periods.

(i) A TR SO₂ Group 1 unit shall be subject to the requirements under paragraph (c)(1), above for the control period starting on the later of January 1, 2015 or the deadline for meeting the unit's monitor certification requirements under 40 CFR §97.630(b) and for each control period thereafter.

(ii) A TR SO₂ Group 1 unit shall be subject to the requirements under paragraph (c)(2), above for the control period starting on the later of January 1, 2017 or the deadline for meeting the unit's monitor certification requirements under 40 CFR §97.630(b) and for each control period thereafter.

(4) Vintage of allowances held for compliance.

(i) A TR SO₂ Group 1 allowance held for compliance with the requirements under paragraph (c)(1)(i), above for a control period in a given year must be a TR SO₂ Group 1 allowance that was allocated for such control period or a control period in a prior year.

(ii) A TR SO₂ Group 1 allowance held for compliance with the requirements under paragraphs (c)(1)(ii)(A) and (2)(i) through (iii), above, for a control period in a given year must be a TR SO₂ Group 1 allowance that was allocated for a control period in a prior year or the control period in the given year or in the immediately following year.

(5) Allowance Management System requirements. Each TR SO₂ Group 1 allowance shall be held in, deducted from, or transferred into, out of, or between Allowance Management System accounts in accordance with 40 CFR Part 97, Subpart CCCCC.

(6) Limited authorization. A TR SO₂ Group 1 allowance is a limited authorization to emit one ton of SO₂ during the control period in one year. Such authorization is limited in its use and duration as follows:

(i) Such authorization shall only be used in accordance with the TR SO₂ Group 1 Trading Program; and

(ii) Notwithstanding any other provision of 40 CFR Part 97, Subpart CCCCC, the Administrator has the authority to terminate or limit the use and duration of such authorization to the extent the Administrator determines is necessary or appropriate to implement any provision of the Clean Air Act.

(7) Property right. A TR SO₂ Group 1 allowance does not constitute a property right.

(d) Title V permit revision requirements.

**SECTION E. Source Group Restrictions.**

(1) No Title V permit revision shall be required for any allocation, holding, deduction, or transfer of TR SO₂ Group 1 allowances in accordance with 40 CFR Part 97, Subpart CCCCC.

(2) This permit incorporates the TR emissions monitoring, recordkeeping and reporting requirements pursuant to 40 CFR §§97.630 through 97.635, and the requirements for a continuous emission monitoring system (pursuant to 40 CFR Part 75, Subparts B and H), an excepted monitoring system (pursuant to 40 CFR Part 75, Appendices D and E), a low mass emissions excepted monitoring methodology (pursuant to 40 CFR Part 75.19), and an alternative monitoring system (pursuant to 40 CFR Part 75, Subpart E). Therefore, the Description of TR Monitoring Provisions table for units identified in this permit may be added to, or changed, in this Title V permit using minor permit modification procedures in accordance with 40 CFR §§97.606(d)(2) and 70.7(e)(2)(i)(B) or 71.7(e)(1)(i)(B).

(e) Additional recordkeeping and reporting requirements.

(1) Unless otherwise provided, the owners and operators of each TR SO₂ Group 1 source and each TR SO₂ Group 1 unit at the source shall keep on site at the source each of the following documents (in hardcopy or electronic format) for a period of 5 years from the date the document is created. This period may be extended for cause, at any time before the end of 5 years, in writing by the Administrator.

(i) The certificate of representation under 40 CFR §97.616 for the designated representative for the source and each TR SO₂ Group 1 unit at the source and all documents that demonstrate the truth of the statements in the certificate of representation; provided that the certificate and documents shall be retained on site at the source beyond such 5-year period until such certificate of representation and documents are superseded because of the submission of a new certificate of representation under 40 CFR §97.616 changing the designated representative.

(ii) All emissions monitoring information, in accordance with 40 CFR Part 97, Subpart CCCCC.

(iii) Copies of all reports, compliance certifications, and other submissions and all records made or required under, or to demonstrate compliance with the requirements of, the TR SO₂ Group 1 Trading Program.

(2) The designated representative of a TR SO₂ Group 1 source and each TR SO₂ Group 1 unit at the source shall make all submissions required under the TR SO₂ Group 1 Trading Program, except as provided in 40 CFR §97.618. This requirement does not change, create an exemption from, or otherwise affect the responsible official submission requirements under a Title V operating permit program in 40 CFR Parts 70 and 71.

(f) Liability.

(1) Any provision of the TR SO₂ Group 1 Trading Program that applies to a TR SO₂ Group 1 source or the designated representative of a TR SO₂ Group 1 source shall also apply to the owners and operators of such source and of the TR SO₂ Group 1 units at the source.

(2) Any provision of the TR SO₂ Group 1 Trading Program that applies to a TR SO₂ Group 1 unit or the designated representative of a TR SO₂ Group 1 unit shall also apply to the owners and operators of such unit.

(g) Effect on other authorities.

No provision of the TR SO₂ Group 1 Trading Program or exemption under 40 CFR §97.605 shall be construed as exempting or excluding the owners and operators, and the designated representative, of a TR SO₂ Group 1 source or TR SO₂ Group 1 unit from compliance with any other provision of the applicable, approved state implementation plan (SIP), a federally enforceable permit, or the Clean Air Act.

003 [25 Pa. Code §127.512]

Operating permit terms and conditions.

(a) The Group 008 utility boilers are subject to the Transport Rule (TR) Trading Program Title V Requirements outlined in this Source Group.

(b) The Transport Rule (TR) is also known as the "Cross-State Air Pollution Rule" (CSAPR). It includes the regulations found at 40 CFR §§52.38, 52.39, 52.2040 and 52.2041, and 40 CFR Part 97, Subparts AAAAA, EEEEE and CCCCC (relating to TR NO_x Annual trading program; TR NO_x Ozone Season Group 2 trading program; and TR SO₂ Group 1 trading

**SECTION E. Source Group Restrictions.**

program).

004 [25 Pa. Code §127.512]**Operating permit terms and conditions.**

In the event that 40 CFR 97 Subpart(s) are revised, the permittee shall comply with the revised version of the subpart(s), and shall not be required to comply with any provisions in this permit designated as having the subpart as their authority, to the extent that such permit provisions would be inconsistent with the applicable provisions of the revised subpart.

***** Permit Shield in Effect. *****

**SECTION E. Source Group Restrictions.**

Group Name: GROUP 009

Group Description: Sources Subject to MACT Subpart UUUUU

Sources included in this group

ID	Name
031A	BRUNNER ISLAND UNIT 1
032	BRUNNER ISLAND UNIT 2
033A	BRUNNER ISLAND UNIT 3

I. RESTRICTIONS.**Emission Restriction(s).****# 001 [25 Pa. Code §127.512]****Operating permit terms and conditions.**

[Additional authority for this permit condition is also derived from 40 CFR §63.9991 "What emission limitations, work practice standards, and operating limits must I meet?"]

(a) You must meet the requirements in 40 CFR §63.9991(a)(1) and (2), below. You must meet these requirements at all times.

(1) You must meet each emission limit and work practice standard in Tables 1 through 3 to 40 CFR Part 63, Subpart UUUUU, that applies to your EGU, for each EGU at your source, except as provided under 40 CFR §63.10009. [NOTE: THE EGUs ARE SUBJECT TO THE EMISSION LIMITS IN TABLE 2, BELOW, AND THE WORK PRACTICE STANDARDS IN TABLE 3, BELOW; THE EMISSION LIMITS IN TABLE 1 ARE NOT APPLICABLE]

(2) [N/A - THE OPERATING LIMITS IN TABLE 4 ARE NOT APPLICABLE]

(b) As provided in 40 CFR §63.6(g), the Administrator may approve use of an alternative to the work practice standards in this operating permit condition (i.e., 40 CFR §63.9991).

(c) [N/A - THE PERMITTEE HAS ELECTED TO COMPLY WITH THE HCl EMISSION LIMIT IN TABLE 2; THEREFORE, THE SO₂ EMISSION LIMIT IN TABLE 2 IS NOT APPLICABLE; ALSO, THE EMISSION LIMITS IN TABLE 1 ARE NOT APPLICABLE]

[77 FR 9464, Feb. 16, 2012, as amended at 77 FR 23402, Apr. 19, 2012; 81 FR 20180, Apr. 6, 2016]

Table 2 (Emission Limits for Existing EGUs) to 40 CFR Part 63, Subpart UUUUU - National Emission Standards for Hazardous Air Pollutants: Coal- and Oil-Fired Electric Utility Steam Generating Units

As stated in 40 CFR §63.9991, you must comply with the following applicable emission limits**:

Subcategory 1 (Coal-fired unit not low rank virgin coal):

(a) Filterable particulate matter (FPM) = 0.03 lb/mmBTU or 0.3 lb/MWh*** (Collect a minimum of 1 dscm per run)

[NOTE: SINCE THE PERMITTEE HAS ELECTED TO COMPLY WITH THE ABOVE FPM EMISSION LIMIT, THE TOTAL NON-Hg HAP METALS EMISSION LIMIT AND THE INDIVIDUAL NON-Hg HAP METALS EMISSION LIMIT ARE NOT APPLICABLE]

(b) Hydrogen chloride (HCl) = 0.002 lb/mmBTU or 0.02 lb/MWh*** (For Method 26A, collect a minimum of 0.75 dscm per run; for Method 26, collect a minimum of 120 liters per run; for ASTM D6348-03**** or Method 320, sample for a minimum of 1 hour)

[NOTE: SINCE THE PERMITTEE HAS ELECTED TO COMPLY WITH THE ABOVE HCl EMISSION LIMIT, THE SULFUR DIOXIDE (SO₂) EMISSION LIMIT IS NOT APPLICABLE]

(c) Mercury (Hg) = 1.2 lb/TBTU or 0.013 lb/GWh*** (Hg CEMS or sorbent trap monitoring system)

**SECTION E. Source Group Restrictions.**

Footnotes:

** For LEE emissions testing for total PM and HCl, the required minimum sampling volume must be increased nominally by a factor of two

*** Gross output

**** Incorporated by reference (see 40 CFR §63.14)

[NOTE: THE ABOVE TABLE 2 EMISSION LIMITS REFLECT THE PERMITTEE'S CURRENTLY SELECTED COMPLIANCE OPTIONS FOR THE EGUs]

[81 FR 20192, Apr. 6, 2016]

Table 3 (Work Practice Standards) to 40 CFR Part 63, Subpart UUUUU - National Emission Standards for Hazardous Air Pollutants: Coal- and Oil-Fired Electric Utility Steam Generating Units*

As stated in 40 CFR §63.9991, you must comply with the following applicable work practice standards:

(1) An existing EGU: Conduct a tune-up of the EGU burner and combustion controls at least each 36 calendar months, or each 48 calendar months if neural network combustion optimization software is employed, as specified in 40 CFR §63.10021(e). [NOTE: THE EGUs DO NOT CURRENTLY EMPLOY NEURAL NETWORK COMBUSTION OPTIMIZATION SYSTEMS DURING NORMAL OPERATION]

(2) [N/A - THE EGUs ARE DEFINED AS EXISTING EGUs]

(3) A coal-fired, liquid oil-fired, or solid oil-derived fuel-fired EGU during startup:

(a) You have the option of complying using either of the following work practice standards:

(1) If you choose to comply using paragraph (1) of the definition of "startup" in 40 CFR §63.10042, you must operate all CMS during startup. Startup means either the first-ever firing of fuel in a boiler for the purpose of producing electricity, or the firing of fuel in a boiler after a shutdown event for any purpose. Startup ends when any of the steam from the boiler is used to generate electricity for sale over the grid or for any other purpose (including on-site use). For startup of a unit, you must use clean fuels as defined in 40 CFR §63.10042 for ignition. Once you convert to firing coal, residual oil, or solid oil-derived fuel, you must engage all of the applicable control technologies except dry scrubber and SCR. You must start your dry scrubber and SCR systems, if present, appropriately to comply with relevant standards applicable during normal operation. You must comply with all applicable emissions limits at all times except for periods that meet the applicable definitions of startup and shutdown in this 40 CFR Part 63, Subpart UUUUU. You must keep records during startup periods. You must provide reports concerning activities and startup periods, as specified in 40 CFR §63.10011(g) and 40 CFR §63.10021(h) and (i).

(2) If you choose to comply using paragraph (2) of the definition of "startup" in 40 CFR §63.10042, you must operate all CMS during startup. You must also collect appropriate data, and you must calculate the pollutant emission rate for each hour of startup. For startup of an EGU, you must use one or a combination of the clean fuels defined in §63.10042 to the maximum extent possible, taking into account considerations such as boiler or control device integrity, throughout the startup period. You must have sufficient clean fuel capacity to engage and operate your PM control device within one hour of adding coal, residual oil, or solid oil-derived fuel to the unit. You must meet the startup period work practice requirements as identified in § 63.10020(e). Once you start firing coal, residual oil, or solid oil-derived fuel, you must vent emissions to the main stack(s). You must comply with the applicable emission limits beginning with the hour after startup ends. You must engage and operate your particulate matter control(s) within 1 hour of first firing of coal, residual oil, or solid oil-derived fuel. You must start all other applicable control devices as expeditiously as possible, considering safety and manufacturer/supplier recommendations, but, in any case, when necessary to comply with other standards made applicable to the EGU by a permit limit or a rule other than 40 CFR Part 63, Subpart UUUUU, that require operation of the control devices.

**SECTION E. Source Group Restrictions.**

(b) [N/A - THE EGUs ARE DEFINED AS COAL-FIRED EGUs]

(c) [N/A - THE EGUs DO NOT USE SORBENT TRAPS TO DEMONSTRATE COMPLIANCE WITH THE APPLICABLE Hg EMISSION LIMIT]

(d) You must collect monitoring data during startup periods, as specified in 40 CFR §63.10020(a) and (e). You must keep records during startup periods, as provided in 40 CFR §§63.10032 and 63.10021(h). You must provide reports concerning activities and startup periods, as specified in 40 CFR §§63.10011(g), 63.10021(i), and 63.10031.

(4) A coal-fired, liquid oil-fired, or solid oil-derived fuel-fired EGU during shutdown: You must operate all CMS during shutdown. You must also collect appropriate data, and you must calculate the pollutant emission rate for each hour of shutdown for those pollutants for which a CMS is used. While firing coal, residual oil, or solid oil-derived fuel during shutdown, you must vent emissions to the main stack(s) and operate all applicable control devices and continue to operate those control devices after the cessation of coal, residual oil, or solid oil-derived fuel being fed into the EGU and for as long as possible thereafter considering operational and safety concerns. In any case, you must operate your controls when necessary to comply with other standards made applicable to the EGU by a permit limit or a rule other than this 40 CFR Part 63, Subpart UUUUU, and that require operation of the control devices. If, in addition to the fuel used prior to initiation of shutdown, another fuel must be used to support the shutdown process, that additional fuel must be one or a combination of the clean fuels defined in 40 CFR §63.10042 and must be used to the maximum extent possible, taking into account considerations such as not compromising boiler or control device integrity. You must comply with all applicable emission limits at all times except during startup periods and shutdown periods at which time you must meet this work practice. You must collect monitoring data during shutdown periods, as specified in 40 CFR §63.10020(a). You must keep records during shutdown periods, as provided in 40 CFR §§63.10032 and 63.10021(h). Any fraction of an hour in which shutdown occurs constitutes a full hour of shutdown. You must provide reports concerning activities and shutdown periods, as specified in 40 CFR §§63.10011(g), 63.10021(i), and 63.10031.

[81 FR 20196, Apr. 6, 2016]

002 [25 Pa. Code §127.512]

Operating permit terms and conditions.

[Additional authority for this permit condition is also derived from 40 CFR §63.10009 "May I use emissions averaging to comply with this subpart?"]

(a) - (l) [N/A - THE PERMITTEE HAS NOT ELECTED TO USE EMISSIONS AVERAGING PURSUANT TO 40 CFR §63.10009 TO COMPLY WITH 40 CFR PART 63, SUBPART UUUUU]

(k) Common stack requirements. For a group of two or more existing affected units, each of which vents through a single common stack, you may average emissions to demonstrate compliance with the limits in Table 2 to 40 CFR Part 63, Subpart UUUUU, if you satisfy the requirements in 40 CFR §63.10009(l) or (m), below.

(l) For a group of two or more existing units in the same subcategory and which vent through a common emissions control system to a common stack that does not receive emissions from units in other subcategories or categories, you may treat such averaging group as a single existing unit for purposes of 40 CFR Part 63, Subpart UUUUU, and comply with the requirements of 40 CFR Part 63, Subpart UUUUU, as if the group were a single unit.

(m) For all other groups of units subject to 40 CFR §63.10009(k), above, you may elect to conduct manual performance tests according to procedures specified in 40 CFR §63.10007 in the common stack. If emissions from affected units included in the emissions averaging and from other units not included in the emissions averaging (e.g., in a different subcategory) or other nonaffected units all vent to the common stack, you must shut down the units not included in the emissions averaging and the nonaffected units or vent their emissions to a different stack during the performance test. Alternatively, you may conduct a performance test of the combined emissions in the common stack with all units operating and show that the combined emissions meet the most stringent emissions limit. You may also use a CEMS or sorbent trap monitoring to apply this latter alternative to demonstrate that the combined emissions comply with the most stringent emissions limit on a continuous basis.

(n) [N/A - THE PERMITTEE HAS NOT ELECTED TO USE EMISSIONS AVERAGING PURSUANT TO 40 CFR §63.10009 TO COMPLY WITH 40 CFR PART 63, SUBPART UUUUU]

**SECTION E. Source Group Restrictions.**

[77 FR 9464, Feb. 16, 2012, as amended at 77 FR 23403, Apr. 19, 2012; 78 FR 24085, Apr. 24, 2013; 81 FR 20183, Apr. 6, 2016]

II. TESTING REQUIREMENTS.**# 003 [25 Pa. Code §127.512]****Operating permit terms and conditions.**

[Additional authority for this permit condition is also derived from 40 CFR §63.10005 "What are my initial compliance requirements and by what date must I conduct them?"]

(a) General requirements. For each of your affected EGUs, you must demonstrate initial compliance with each applicable emissions limit in Table 1 or 2 of 40 CFR Part 63, Subpart UUUUU, through performance testing. Where two emissions limits are specified for a particular pollutant (e.g., a heat input-based limit in lb/mmBTU and a gross output-based limit in lb/MWh), you may demonstrate compliance with either emission limit. For a particular compliance demonstration, you may be required to conduct one or more of the following activities in conjunction with performance testing: collection of data (e.g., hourly gross output data [megawatts]); establishment of operating limits according to 40 CFR §63.10011 and Tables 4 and 7 to 40 CFR Part 63, Subpart UUUUU; and CMS performance evaluations. In all cases, you must demonstrate initial compliance no later than the date in 40 CFR §63.10005(f), below, for tune-up work practices for existing EGUs; the date that compliance must be demonstrated, as given in 40 CFR §63.9984 for other requirements for existing EGUs; and in 40 CFR §63.10005(g), below, for all requirements for new EGUs.

(1) To demonstrate initial compliance with an applicable emissions limit in Table 1 or 2 to 40 CFR Part 63, Subpart UUUUU, using stack testing, the initial performance test generally consists of three runs at specified process operating conditions using approved methods. If you are required to establish operating limits (see 40 CFR §63.10005(d), below, and Table 4 to 40 CFR Part 63, Subpart UUUUU), you must collect all applicable parametric data during the performance test period. Also, if you choose to comply with an electrical output-based emission limit, you must collect hourly electrical load data during the test period. [NOTE: THE INITIAL PERFORMANCE TEST TO DEMONSTRATE COMPLIANCE WITH THE APPLICABLE FPM & HCl EMISSION LIMITS OF TABLE 2 WERE CONDUCTED ON 5/21/14 (SOURCE IDs 031A & 032) & 6/17/14 (SOURCE ID 033A)]

(2) To demonstrate initial compliance using either a CMS that measures HAP concentrations directly (i.e., an Hg, HCl, or HF CEMS, or a sorbent trap monitoring system) or an SO₂ or PM CEMS, the initial performance test shall consist of 30- or, for certain coal-fired existing EGUs that use emissions averaging for Hg, 90-boiler operating days. If the CMS is certified prior to the compliance date (or, if applicable, the approved extended compliance date), the test shall begin with the first operating day on or after that date, except as otherwise provided in 40 CFR §63.10005(b), below. If the CMS is not certified prior to the compliance date, the test shall begin with the first operating day after certification testing is successfully completed. In all cases, the initial 30- or 90-operating day averaging period must be completed on or before the date that compliance must be demonstrated (i.e., 180 days after the applicable compliance date). [NOTE: THE INITIAL PERFORMANCE (CEMS) TEST TO DEMONSTRATE COMPLIANCE WITH THE APPLICABLE Hg EMISSION LIMIT OF MACT SUBPART UUUUU TABLE 2 WAS CONDUCTED DURING THE 30-BOILER OPERATING DAY PERIODS OF 4/18/16 – 6/09/16 (SOURCE IDs 031A & 032) AND 6/06/16 – 7/08/16 (SOURCE ID 033A); THE INITIAL PERFORMANCE (CEMS) TESTING WAS REQUIRED TO BEGIN WITH THE FIRST BOILER OPERATING DAY AFTER Hg CEMS CERTIFICATION TESTING IS SUCCESSFULLY COMPLETED; THE Hg CEMS CERTIFICATION TESTING WAS SUCCESSFULLY COMPLETED ON 3/03/16 (SOURCE IDs 031A & 032) AND 3/01/16 (SOURCE ID 033A); THEREFORE, THE AFOREMENTIONED INITIAL PERFORMANCE (CEMS) TESTS DID BEGIN WITH THE FIRST BOILER OPERATING DAY AFTER Hg CEMS CERTIFICATION TESTING WAS SUCCESSFULLY COMPLETED; THE INITIAL Hg PERFORMANCE (CEMS) TESTING WAS REQUIRED TO BE COMPLETED ON OR BEFORE THE DATE THAT COMPLIANCE MUST BE DEMONSTRATED (i.e., 180 DAYS AFTER THE APPLICABLE COMPLIANCE DATE); THIS MEANS THAT THE INITIAL Hg PERFORMANCE (CEMS) TESTING WAS REQUIRED TO HAVE BEEN COMPLETED ON OR BEFORE 10/13/16]

(i) The CMS performance test must demonstrate compliance with the applicable Hg, HCl, HF, PM, or SO₂ emissions limit in Table 1 or 2 to 40 CFR Part 63, Subpart UUUUU.

(ii) You must collect hourly data from auxiliary monitoring systems (i.e., stack gas flow rate, CO₂, O₂, or moisture, as applicable) during the performance test period in order to convert the pollutant concentrations to units of the standard. If you

**SECTION E. Source Group Restrictions.**

choose to comply with a gross output-based emission limit, you must also collect hourly gross output data during the performance test period.

(iii) For a group of affected units that are in the same subcategory, are subject to the same emission standards, and share a common stack, if you elect to demonstrate compliance by monitoring emissions at the common stack, startup and shutdown emissions (if any) that occur during the 30- (or, if applicable, 90-) boiler operating day performance test must either be excluded from or included in the compliance demonstration as follows:

(A) If one of the units that shares the stack either starts up or shuts down at a time when none of the other units is operating, you must exclude all pollutant emission rates measured during the startup or shutdown period, unless you are using a sorbent trap monitoring system to measure Hg emissions and have elected to include startup and shutdown emissions in the compliance demonstrations;

(B) If all units that are currently operating are in the startup or shutdown mode, you must exclude all pollutant emission rates measured during the startup or shutdown period, unless you are using a sorbent trap monitoring system to measure Hg emissions and have elected to include startup and shutdown emissions in the compliance demonstrations; or

(C) If any unit starts up or shuts down at a time when another unit is operating, and the other unit is not in the startup or shutdown mode, you must include all pollutant emission rates measured during the startup or shutdown period in the compliance demonstrations.

(b) Performance testing requirements. If you choose to use performance testing to demonstrate initial compliance with the applicable emissions limits in Tables 1 and 2 to 40 CFR Part 63, Subpart UUUUU, for your EGUs, you must conduct the tests according to 40 CFR §63.10007 and Table 5 to 40 CFR Part 63, Subpart UUUUU. For the purposes of the initial compliance demonstration, you may use test data and results from a performance test conducted prior to the date on which compliance is required as specified in 40 CFR §63.9984, provided that the following conditions are fully met: [NOTE: PERFORMANCE TESTING TO DEMONSTRATE INITIAL COMPLIANCE WITH THE APPLICABLE TABLE 2 FPM & HCl EMISSION LIMITS WAS CHOSEN; ADDITIONALLY, TEST DATA AND RESULTS FROM A PERFORMANCE TEST CONDUCTED PRIOR TO THE COMPLIANCE DATE WAS USED]

(c) [N/A - THE EGUs ARE CURRENTLY NOT EQUIPPED WITH A PM CPMS]

(d) CMS requirements. If, for a particular emission or operating limit, you are required to (or elect to) demonstrate initial compliance using a continuous monitoring system (CMS), the CMS must pass a performance evaluation prior to the initial compliance demonstration. If a CMS has been previously certified under another state or federal program and is continuing to meet the on-going quality-assurance (QA) requirements of that program, then, provided that the certification and QA provisions of that program meet the applicable requirements of 40 CFR §§63.10010(b) through (h), an additional performance evaluation of the CMS is not required under 40 CFR Part 63, Subpart UUUUU.

(1) [N/A - INITIAL COMPLIANCE WITH THE APPLICABLE FPM, SO₂, HCl, or HF EMISSIONS LIMIT IN TABLE 2 WAS NOT DEMONSTRATED VIA CEMS]

(2) [N/A - THE EGUs ARE CURRENTLY NOT EQUIPPED WITH A PM CPMS]

(3) For affected EGUs that are either required to or elect to demonstrate initial compliance with the applicable Hg emission limit in Table 1 or 2 of 40 CFR Part 63, Subpart UUUUU, using Hg CEMS or sorbent trap monitoring systems, initial compliance must be demonstrated no later than the applicable date specified in §63.9984(f) for existing EGUs and in 40 CFR §63.10005(g), below, for new EGUs. Initial compliance is achieved if the arithmetic average of 30- (or 90-) boiler operating days of quality-assured CEMS (or sorbent trap monitoring system) data, expressed in units of the standard (see Section 6.2 of Appendix A to 40 CFR Part 63, Subpart UUUUU), meets the applicable Hg emission limit in Table 1 or 2 to 40 CFR Part 63, Subpart UUUUU.

(4) [N/A - THE EGUs ARE DEFINED AS COAL-FIRED EGUs]

(e) Tune-ups. All affected EGUs are subject to the work practice standards in Table 3 to 40 CFR Part 63, Subpart UUUUU. As part of your initial compliance demonstration, you must conduct a performance tune-up of your EGU according to 40 CFR §63.10021(e). [NOTE: THE INITIAL TUNE-UP OF EACH EGU WAS COMPLETED ON 8/28/15]

**SECTION E. Source Group Restrictions.**

(f) For an existing EGU without a neural network, a tune-up, following the procedures in 40 CFR §63.10021(e), must occur within 6 months (180 days) after April 16, 2015. For an existing EGU with a neural network, a tune-up must occur within 18 months (545 days) after April 16, 2016. If a tune-up occurs prior to April 16, 2015, you must keep records showing that the tune-up met all rule requirements. [NOTE: THE EGUS DO NOT CURRENTLY EMPLOY NEURAL NETWORK COMBUSTION OPTIMIZATION SYSTEMS DURING NORMAL OPERATION; THEREFORE, THEREFORE, THE INITIAL TUNE-UP OF EACH EGU WAS REQUIRED TO BE COMPLETED NO LATER THAN 10/13/15; THE INITIAL TUNE-UP OF EACH EGU WAS COMPLETED ON 8/28/15]

(g) [N/A - THE EGUS ARE DEFINED AS EXISTING EGUS]

(h) Low emitting EGUs. The provisions of this paragraph [40 CFR §63.10005(h)] apply to pollutants with emissions limits from new EGUs except Hg and to all pollutants with emissions limits from existing EGUs. You may pursue this compliance option unless prohibited pursuant to 40 CFR §63.10000(c)(1)(i). [NOTE: THE EGUS ARE DEFINED AS EXISTING EGUS]

(1) An EGU may qualify for low emitting EGU (LEE) status for Hg, HCl, HF, filterable PM (FPM), total non-Hg HAP metals, or individual non-Hg HAP metals (or total HAP metals or individual HAP metals, for liquid oil-fired EGUs) if you collect performance test data that meet the requirements of this paragraph [40 CFR §63.10005(h)], and if those data demonstrate:

(i) For all pollutants except Hg, performance test emissions results less than 50 percent of the applicable emissions limits in Table 1 or 2 to 40 CFR Part 63, Subpart UUUUU, for all required testing for 3 consecutive years; or

(ii) [N/A - THE PERMITTEE HAS CURRENTLY ELECTED TO NOT SEEK Hg LEE STATUS]

[NOTE: THE EGUS HAVE ACHIEVED LEE STATUS FOR FPM & HCl]

(2) For all pollutants except Hg, you must conduct all required performance tests described in 40 CFR §63.10007 to demonstrate that a unit qualifies for LEE status.

(i) When conducting emissions testing to demonstrate LEE status, you must increase the minimum sample volume specified in Table 1 or 2 nominally by a factor of two.

(ii) Follow the instructions in 40 CFR §63.10007(e) and Table 5 to 40 CFR Part 63, Subpart UUUUU, to convert the test data to the units of the applicable standard.

(3) [N/A - THE PERMITTEE HAS CURRENTLY ELECTED TO NOT SEEK Hg LEE STATUS]

(4) For a group of affected units that vent to a common stack, you may either assess LEE status for the units individually by performing a separate emission test of each unit in the duct leading from the unit to the common stack, or you may perform a single emission test in the common stack. If you choose the common stack testing option, the units in the configuration qualify for LEE status if:

(i) The emission rate measured at the common stack is less than 50 percent (10 percent for Hg) of the applicable emission limit in Table 1 or 2 to 40 CFR Part 63, Subpart UUUUU; or

(ii) [N/A - THE PERMITTEE HAS CURRENTLY ELECTED TO NOT SEEK Hg LEE STATUS]

(5) [N/A - THE EGUS HAVE A SINGLE OR COMMON STACK OR DUCT CONFIGURATION]

(i) [N/A - THE EGUS ARE DEFINED AS COAL-FIRED EGUS]

(j) Startup and shutdown for coal-fired or solid oil derived-fired units. You must follow the requirements given in Table 3 to 40 CFR Part 63, Subpart UUUUU.

(k) You must submit a Notification of Compliance Status summarizing the results of your initial compliance demonstration, as provided in 40 CFR §63.10030. [NOTE: THE PERMITTEE SUBMITTED THE NOTIFICATION OF COMPLIANCE STATUS TO U.S. EPA VIA CEDRI ON 11/13/17]

**SECTION E. Source Group Restrictions.**

[77 FR 9464, Feb. 16, 2012, as amended at 77 FR 23403, Apr. 19, 2012; 78 FR 24084, Apr. 24, 2013; 79 FR 68789, Nov. 19, 2014; 81 FR 20181, Apr. 6, 2016]

004 [25 Pa. Code §127.512]**Operating permit terms and conditions.**

[Additional authority for this permit condition is also derived from 40 CFR §63.10006 "When must I conduct subsequent performance tests or tune-ups?"]

(a) [N/A - THE EGUs ARE CURRENTLY NOT EQUIPPED WITH A PM CPMS]

(b) For affected units meeting the LEE requirements of 40 CFR §63.10005(h), you must repeat the performance test once every 3 years (once every year for Hg) according to Table 5 to 40 CFR Part 63, Subpart UUUUU, and 40 CFR §63.10007. Should subsequent emissions testing results show the unit does not meet the LEE eligibility requirements, LEE status is lost. If this should occur:

(1) For all pollutant emission limits except for Hg, you must conduct emissions testing quarterly, except as otherwise provided in 40 CFR §63.10021(d)(1).

(2) [N/A - THE PERMITTEE HAS CURRENTLY ELECTED TO NOT SEEK Hg LEE STATUS]

[NOTE: THE EGUs HAVE ACHIEVED LEE STATUS FOR FPM & HCl]

(c) Except where 40 CFR §63.10006(a) or (b), above, apply, or where you install, certify, and operate a PM CEMS to demonstrate compliance with a filterable PM (FPM) emissions limit, for liquid oil-, solid oil-derived fuel-, coal-fired and IGCC EGUs, you must conduct all applicable periodic emissions tests for filterable PM (FPM), individual, or total HAP metals emissions according to Table 5 to 40 CFR Part 63, Subpart UUUUU, 40 CFR §63.10007, and 40 CFR §63.10000(c), except as otherwise provided in 40 CFR §63.10021(d)(1). [NOTE: THE EGUs HAVE ACHIEVED LEE STATUS FOR FPM AND ARE CURRENTLY USING PERIODIC EMISSIONS TESTS TO DEMONSTRATE COMPLIANCE]

(d) Except where 40 CFR §63.10006(b), above, applies, for solid oil-derived fuel- and coal-fired EGUs that do not use either an HCl CEMS to monitor compliance with the HCl limit or an SO₂ CEMS to monitor compliance with the alternate equivalent SO₂ emission limit, you must conduct all applicable periodic HCl emissions tests according to Table 5 to 40 CFR Part 63, Subpart UUUUU, and 40 CFR §63.10007 at least quarterly, except as otherwise provided in 40 CFR §63.10021(d)(1). [NOTE: THE EGUs HAVE ACHIEVED LEE STATUS FOR HCl AND ARE CURRENTLY USING PERIODIC EMISSIONS TESTS TO DEMONSTRATE COMPLIANCE]

(e) [N/A - THE EGUs ARE DEFINED AS COAL-FIRED EGUs]

(f) Time between performance tests. (1) Notwithstanding the provisions of 40 CFR §63.10021(d)(1), the requirements listed in 40 CFR §63.10006(g) and (h), below, and the requirements of 40 CFR §63.10006(f)(3), below, you must complete performance tests for your EGU as follows:

(i) At least 45 calendar days, measured from the test's end date, must separate performance tests conducted every quarter;

(ii) For annual testing:

(A) At least 320 calendar days, measured from the test's end date, must separate performance tests;

(B) [N/A - THE PERMITTEE HAS CURRENTLY ELECTED TO NOT SEEK Hg LEE STATUS]

(C) [N/A - THE PERMITTEE HAS CURRENTLY ELECTED TO NOT SEEK Hg LEE STATUS]; and

(iii) At least 1,050 calendar days, measured from the test's end date, must separate performance tests conducted every 3 years.

(2) For units demonstrating compliance through quarterly emission testing, you must conduct a performance test in the 4th

**SECTION E. Source Group Restrictions.**

quarter of a calendar year if your EGU has skipped performance tests in the first 3 quarters of the calendar year.

(3) If your EGU misses a performance test deadline due to being inoperative and if 168 or more boiler operating hours occur in the next test period, you must complete an additional performance test in that period as follows:

- (i) At least 15 calendar days must separate two performance tests conducted in the same quarter.
- (ii) At least 107 calendar days must separate two performance tests conducted in the same calendar year.
- (iii) At least 350 calendar days must separate two performance tests conducted in the same 3 year period.

(g) [N/A - THE PERMITTEE HAS ELECTED TO NOT USE EMISSIONS AVERAGING AS AN ALTERNATIVE TO COMPLYING WITH THE FPM, HCl or Hg EMISSION LIMITS OF 40 CFR §63.9991]

(h) If a performance test on a non-mercury LEE shows emissions in excess of 50 percent of the emission limit and if you choose to reapply for LEE status, you must conduct performance tests at the appropriate frequency given in 40 CFR §63.10006(c) through (e), above, for that pollutant until all performance tests over a consecutive 3-year period show compliance with the LEE criteria.

(i) If you are required to meet an applicable tune-up work practice standard, you must conduct a performance tune-up according to 40 CFR §63.10021(e).

(1) For EGUs not employing neural network combustion optimization during normal operation, each performance tune-up specified in 40 CFR §63.10021(e) must be no more than 36 calendar months after the previous performance tune-up.

(2) [N/A - THE EGUs DO NOT CURRENTLY EMPLOY NEURAL NETWORK COMBUSTION OPTIMIZATION SYSTEMS DURING NORMAL OPERATION]

[77 FR 9464, Feb. 16, 2012, as amended at 77 FR 23403, Apr. 19, 2012; 78 FR 24085, Apr. 24, 2013; 81 FR 20182, Apr. 6, 2016]

Table 5 (Performance Testing Requirements) to 40 CFR Part 63, Subpart UUUUU - National Emission Standards for Hazardous Air Pollutants: Coal- and Oil-Fired Electric Utility Steam Generating Units

As stated in 40 CFR §63.10007, you must comply with the following requirements for performance testing for existing, new or reconstructed affected sources**:

(a) To conduct a performance test for filterable particulate matter (PM) using emissions testing, you must perform the following activities as applicable to your input- or output-based emission limit:

- (1) Select sampling ports location and the number of traverse points using Method 1 at Appendix A-1 to 40 CFR Part 60.
- (2) Determine velocity and volumetric flow-rate of the stack gas using Method 2, 2A, 2C, 2F, 2G or 2H at Appendix A-1 or A-2 to 40 CFR Part 60.
- (3) Determine oxygen and carbon dioxide concentrations of the stack gas using Method 3A or 3B at Appendix A-2 to 40 CFR Part 60, or ANSI/ASME PTC 19.10-1981***.
- (4) Measure the moisture content of the stack gas using Method 4 at Appendix A-3 to 40 CFR Part 60.
- (5) Measure the filterable PM concentration using Method 5 at Appendix A-3 to 40 CFR Part 60 (For positive pressure fabric filters, use Method 5D at Appendix A-3 to 40 CFR Part 60 for filterable PM emissions; note that the Method 5 front half temperature shall be $160^{\circ} \pm 14^{\circ}\text{C}$ ($320^{\circ} \pm 25^{\circ}\text{F}$)).
- (6) Convert emissions concentration to lb/mmBTU or lb/MWh emissions rates using Method 19 F-factor methodology at

**SECTION E. Source Group Restrictions.**

Appendix A-7 to 40 CFR Part 60, or calculate using mass emissions rate and electrical output data [see 40 CFR §63.10007(e)].

(b) [N/A - THE EGUs ARE NOT EQUIPPED WITH FPM CEMS]

(c) [N/A - SINCE THE PERMITTEE HAS ELECTED TO COMPLY WITH THE FPM EMISSION LIMIT, THE TOTAL NON-Hg HAP METALS EMISSION LIMIT AND THE INDIVIDUAL NON-Hg HAP METALS EMISSION LIMIT ARE NOT APPLICABLE]

(d) To conduct a performance test for hydrogen chloride (HCl) and hydrogen fluoride (HF) using emissions testing, you must perform the following activities as applicable to your input- or output-based emission limit:

(1) Select sampling ports location and the number of traverse points using Method 1 at Appendix A-1 to 40 CFR Part 60.

(2) Determine velocity and volumetric flow-rate of the stack gas using Method 2, 2A, 2C, 2F, 2G or 2H at Appendix A-1 or A-2 to 40 CFR Part 60.

(3) Determine oxygen and carbon dioxide concentrations of the stack gas using Method 3A or 3B at Appendix A-2 to 40 CFR Part 60, or ANSI/ASME PTC 19.10-1981***.

(4) Measure the moisture content of the stack gas using Method 4 at Appendix A-3 to 40 CFR Part 60.

(5) Measure the HCl and HF emissions concentrations using Method 26 or Method 26A at Appendix A-8 to 40 CFR Part 60 or Method 320 at Appendix A to 40 CFR Part 63 or ASTM D6348-03*** with:

(1) the following conditions when using ASTM D6348-03:

(A) The test plan preparation and implementation in the Annexes to ASTM D6348-03, Sections A1 through A8 are mandatory;

(B) For ASTM D6348-03 Annex A5 (Analyte Spiking Technique), the percent (%) R must be determined for each target analyte (see Equation A5.5);

(C) For the ASTM D6348-03 test data to be acceptable for a target analyte, %R must be 70% = R = 130%; and

(D) The %R value for each compound must be reported in the test report and all field measurements corrected with the calculated %R value for that compound using the following equation:

$$\text{Reported Result} = \frac{(\text{Measured Concentration in Stack})}{\%R} \times 100$$

and

(2) spiking levels nominally no greater than two times the level corresponding to the applicable emission limit. Method 26A must be used if there are entrained water droplets in the exhaust stream.

(6) Convert emissions concentration to lb/mmBTU or lb/MWh emissions rates using Method 19 F-factor methodology at Appendix A-7 to 40 CFR Part 60, or calculate using mass emissions rate and electrical output data [see 40 CFR §63.10007(e)].

(e) [N/A - THE EGUs ARE NOT EQUIPPED WITH HCl CEMS]

(f) [N/A - THE PERMITTEE HAS ELECTED TO USE CEMS TO DEMONSTRATE COMPLIANCE WITH THE TABLE 2 Hg EMISSION LIMIT]

(g) To conduct a performance test for Hg using Hg CEMS, you must perform the following activities as applicable to your input- or output-based emission limit:

**SECTION E. Source Group Restrictions.**

- (1) Install, certify, operate, and maintain the CEMS using Sections 3.2.1 and 5.1 of Appendix A of 40 CFR Part 63, Subpart UUUUU.
- (2) Install, certify, operate, and maintain the diluent gas, flow rate, and/or moisture monitoring systems using 40 CFR Part 75 and 40 CFR §§63.10010(a), (b), (c), and (d).
- (3) Convert hourly emissions concentrations to 30-boiler operating day rolling average lb/TBTU or lb/GWh emissions rates using Section 6 of Appendix A to 40 CFR Part 63, Subpart UUUUU.
- (h) [N/A - THE PERMITTEE HAS ELECTED TO USE CEMS TO DEMONSTRATE COMPLIANCE WITH THE TABLE 2 Hg EMISSION LIMIT]
- (i) [N/A - THE PERMITTEE HAS CURRENTLY ELECTED TO NOT SEEK Hg LEE STATUS]
- (j) [N/A - THE PERMITTEE HAS ELECTED TO COMPLY WITH THE TABLE 2 HCl EMISSION LIMIT; THEREFORE, THE TABLE 2 SO₂ EMISSION LIMIT IS NOT APPLICABLE]

Footnotes:

** Regarding emissions data collected during periods of startup or shutdown, see 40 CFR §§63.10020(b) and (c), and 40 CFR §63.10021(h)

*** Incorporated by reference, see 40 CFR §63.14

SPECIAL NOTE: SEE TABLE 2 TO 40 CFR PART 63, SUBPART UUUUU, FOR REQUIRED SAMPLE VOLUMES AND/OR SAMPLING RUN TIMES.

[83 FR 56727, Nov. 14, 2018]

005 [25 Pa. Code §127.512]**Operating permit terms and conditions.**

[Additional authority for this permit condition is also derived from 40 CFR §63.10007 "What methods and other procedures must I use for the performance tests?"]

(a) Except as otherwise provided in this operating permit condition (40 CFR §63.10007), you must conduct all required performance tests according to 40 CFR §63.7(d), (e), (f), and (h). You must also develop a site-specific test plan according to the requirements in 40 CFR §63.7(c).

(1) If you use CEMS (Hg, HCl, SO₂, or other) to determine compliance with a 30- (or, if applicable, 90-) boiler operating day rolling average emission limit, you must collect quality-assured CEMS data for all unit operating conditions, including startup and shutdown (see 40 CFR §63.10011(g) and Table 3 to 40 CFR Part 63, Subpart UUUUU), except as otherwise provided in 40 CFR §63.10020(b). Emission rates determined during startup periods and shutdown periods (as defined in 40 CFR §63.10042) are not to be included in the compliance determinations, except as otherwise provided in 40 CFR §§63.10000(c)(1)(vi)(B) and 63.10005(a)(2)(iii). [NOTE: THE EGUs CURRENTLY UTILIZE Hg CEMS; CEMS ARE NOT THE CURRENTLY SELECTED COMPLIANCE OPTION FOR THE OTHER POLLUTANTS]

(2) If you conduct performance testing with test methods in lieu of continuous monitoring, operate the unit at maximum normal operating load conditions during each periodic (e.g., quarterly) performance test. Maximum normal operating load will be generally between 90 and 110 percent of design capacity but should be representative of site-specific normal operations during each test run.

(3) [N/A - THE EGUs ARE CURRENTLY NOT EQUIPPED WITH A PM CPMS]

(b) You must conduct each performance test (including traditional 3-run stack tests, 30-boiler operating day tests based on CEMS data (or sorbent trap monitoring system data), and 30-boiler operating day Hg emissions tests for LEE qualification) according to the requirements in Table 5 to 40 CFR Part 63, Subpart UUUUU.

(c) [N/A - THE EGUs ARE CURRENTLY NOT EQUIPPED WITH A PM CPMS]

**SECTION E. Source Group Restrictions.**

(d) Except for a 30-boiler operating day performance test based on CEMS (or sorbent trap monitoring system) data, where the concept of test runs does not apply, you must conduct a minimum of three separate test runs for each performance test, as specified in 40 CFR §63.7(e)(3). Each test run must comply with the minimum applicable sampling time or volume specified in Table 1 or 2 to 40 CFR Part 63, Subpart UUUUU. 40 CFR §63.10005(d) and (h), respectively, provide special instructions for conducting performance tests based on CEMS or sorbent trap monitoring systems, and for conducting emission tests for LEE qualification.

(e) To use the results of performance testing to determine compliance with the applicable emission limits in Table 1 or 2 to 40 CFR Part 63, Subpart UUUUU, proceed as follows:

(1) Except for a 30-boiler operating day performance test based on CEMS (or sorbent trap monitoring system) data, if measurement results for any pollutant are reported as below the method detection level (e.g., laboratory analytical results for one or more sample components are below the method-defined analytical detection level), you must use the method detection level as the measured emissions level for that pollutant in calculating compliance. The measured result for a multiple component analysis (e.g., analytical values for multiple Method 29 fractions both for individual HAP metals and for total HAP metals) may include a combination of method detection level data and analytical data reported above the method detection level.

(2) If the limits are expressed in lb/mmBTU or lb/TBTU, you must use the F-factor methodology and equations in Sections 12.2 and 12.3 of EPA Method 19 in Appendix A-7 to 40 CFR Part 60. In cases where an appropriate F-factor is not listed in Table 19-2 of Method 19, you may use F-factors from Table 1 in Section 3.3.5 of Appendix F to 40 CFR Part 75, or F-factors derived using the procedures in Section 3.3.6 of Appendix to 40 CFR Part 75. Use the following factors to convert the pollutant concentrations measured during the initial performance tests to units of lb/scf for use in the applicable Method 19 equations:

(i) [N/A - THE PERMITTEE HAS ELECTED TO COMPLY WITH THE TABLE 2 HCl EMISSION LIMIT; THEREFORE, THE TABLE 2 SO₂ EMISSION LIMIT IS NOT APPLICABLE];

(ii) Multiply HCl ppm by 0.0000000943;

(iii) [N/A - THERE IS NO APPLICABLE TABLE 2 HF EMISSION LIMIT];

(iv) [N/A - THE PERMITTEE HAS ELECTED TO COMPLY WITH THE TABLE 2 FPM EMISSION LIMIT; THEREFORE, THE TABLE 2 INDIVIDUAL/TOTAL NON-Hg HAP METALS EMISSION LIMITS ARE NOT APPLICABLE]; and

(v) Multiply Hg concentrations (µg/scm) by 0.000000000624.

(3) To determine compliance with emission limits expressed in lb/MWh or lb/GWh, you must first calculate the pollutant mass emission rate during the performance test, in units of lb/hr. For Hg, if a CEMS or sorbent trap monitoring system is used, use Equation A-2 or A-3 in Appendix A to 40 CFR Part 63, Subpart UUUUU (as applicable). In all other cases, use an equation that has the general form of Equation A-2 or A-3 Appendix A to 40 CFR Part 63, Subpart UUUUU, replacing the value of K with 0.000000166 lb/scf-ppm for SO₂, 0.0000000943 lb/scf-ppm for HCl (if an HCl CEMS is used), 0.0000000518 lb/scf-ppm for HF (if an HF CEMS is used), or 0.0000000624 scm/mg-scf for HAP metals and for HCl and HF (when performance stack testing is used), and defining Ch as the average SO₂, HCl, or HF concentration in ppm, or the average HAP metals concentration in mg/dscm. This calculation requires stack gas volumetric flow rate (scfh) and (in some cases) moisture content data (see 40 CFR §§63.10005(h)(3) and 63.10010). Then, if the applicable emission limit is in units of lb/GWh, use Equation A-4 in Appendix A to 40 CFR Part 63, Subpart UUUUU, to calculate the pollutant emission rate in lb/GWh. In this calculation, define (M)h as the calculated pollutant mass emission rate for the performance test (lb/hr), and define (MW)h as the average electrical load during the performance test (megawatts). If the applicable emission limit is in lb/MWh rather than lb/GWh, omit the "x 1000" multiplier term from Equation A-4 to determine the pollutant emission rate in lb/MWh.

(f) If you elect to (or are required to) use CEMS to continuously monitor Hg, HCl, HF, SO₂, or PM emissions (or, if applicable, sorbent trap monitoring systems to continuously collect Hg emissions data), the following default values are available for use in the emission rate calculations during startup periods or shutdown periods (as defined in §63.10042). For the purposes of this subpart, these default values are not considered to be substitute data.

**SECTION E. Source Group Restrictions.**

(1) Diluent cap values. If you use CEMS (or, if applicable, sorbent trap monitoring systems) to comply with a heat input-based emission rate limit, you may use the following diluent cap values for a startup or shutdown hour in which the measured CO₂ concentration is below the cap value or the measured O₂ concentration is above the cap value:

- (i) [N/A - EGUS ARE NOT IGCC EGUs]
- (ii) For all other EGUs, you may use 5% for CO₂ or 14% for O₂.

(2) Default gross output. If you use CEMS to continuously monitor Hg, HCl, HF, SO₂, or PM emissions (or, if applicable, sorbent trap monitoring systems to continuously collect Hg emissions data), the following default value is available for use in the emission rate calculations during startup periods or shutdown periods (as defined in 40 CFR §63.10042). For the purposes of 40 CFR Part 63, Subpart UUUUU, this default value is not considered to be substitute data. For a startup or shutdown hour in which there is heat input to an affected EGU but zero gross output, you must calculate the pollutant emission rate using a value equivalent to 5% of the maximum sustainable gross output, expressed in megawatts, as defined in Section 6.5.2.1(a)(1) of Appendix A to 40 CFR Part 75. This default gross output is either the nameplate capacity of the EGU or the highest gross output observed in at least four representative quarters of EGU operation. For a monitored common stack, the default gross output is used only when all EGUs are operating (i.e., combusting fuel) are in startup or shutdown mode, and have zero electrical generation. Under those conditions, a default gross output equal to 5% of the combined maximum sustainable gross output of the EGUs that are operating but have a total of zero gross output must be used to calculate the hourly gross output-based pollutant emissions rate.

(g) Upon request, you shall make available to the EPA Administrator such records as may be necessary to determine whether the performance tests have been done according to the requirements of this operating permit condition (40 CFR §63.10007).

[77 FR 9464, Feb. 16, 2012, as amended at 77 FR 23403, Apr. 19, 2012; 78 FR 24085, Apr. 24, 2013; 79 FR 68789, Nov. 19, 2014; 81 FR 20182, Apr. 6, 2016]

III. MONITORING REQUIREMENTS.**# 006 [25 Pa. Code §127.511]****Monitoring and related recordkeeping and reporting requirements.**

[Additional authority for this permit condition is also derived from 40 CFR §63.10020 "How do I monitor and collect data to demonstrate continuous compliance?"]

(a) You must monitor and collect data according to this operating permit condition (40 CFR §63.10020) and the site-specific monitoring plan required by 40 CFR §63.10000(d).

(b) You must operate the monitoring system and collect data at all required intervals at all times that the affected EGU is operating, except for periods of monitoring system malfunctions or out-of-control periods [see 40 CFR §63.8(c)(7)], and required monitoring system quality assurance or quality control activities, including, as applicable, calibration checks and required zero and span adjustments. You are required to affect monitoring system repairs in response to monitoring system malfunctions and to return the monitoring system to operation as expeditiously as practicable.

(c) You may not use data recorded during EGU startup or shutdown in calculations used to report emissions, except as otherwise provided in 40 CFR §§63.10000(c)(1)(vi)(B) and 63.10005(a)(2)(iii) [NOTE: HOWEVER, THIS DOES NOT INCLUDE THE AIR EMISSIONS INFORMATION ADDRESSED IN SECTION C OF THIS OPERATING PERMIT]. In addition, data recorded during monitoring system malfunctions or monitoring system out-of-control periods, repairs associated with monitoring system malfunctions or monitoring system out-of-control periods, or required monitoring system quality assurance or control activities may not be used in calculations used to report emissions or operating levels. You must use all of the quality-assured data collected during all other periods in assessing the operation of the control device and associated control system.

(d) Except for periods of monitoring system malfunctions or monitoring system out-of-control periods, repairs associated with monitoring system malfunctions or monitoring system out-of-control periods, and required monitoring system quality assurance or quality control activities including, as applicable, calibration checks and required zero and span adjustments, failure to collect required data is a deviation from the monitoring requirements.

**SECTION E. Source Group Restrictions.**

(e) [N/A - THE PERMITTEE HAS ELECTED TO COMPLY USING PARAGRAPH (1) OF THE DEFINITION OF "STARTUP" IN 40 CFR §63.10042]

[77 FR 9464, Feb. 16, 2012, as amended at 77 FR 23404, Apr. 19, 2012; 79 FR 68790, Nov. 19, 2014; 81 FR 20187, Apr. 6, 2016]

007 [25 Pa. Code §127.511]**Monitoring and related recordkeeping and reporting requirements.**

[Additional authority for this permit condition is also derived from 40 CFR §63.10021 "How do I demonstrate continuous compliance with the emission limitations, operating limits, and work practice standards?"]

(a) You must demonstrate continuous compliance with each emissions limit, operating limit, and work practice standard in Tables 1 through 4 to 40 CFR Part 63, Subpart UUUUU, that applies to you according to the monitoring specified in Tables 6 and 7 to 40 CFR Part 63, Subpart UUUUU, and 40 CFR §63.10021(b) through (g), below.

(b) Except as otherwise provided in 40 CFR §63.10020(c), if you use a CEMS to measure SO₂, PM, HCl, HF, or Hg emissions, or using a sorbent trap monitoring system to measure Hg emissions, you must demonstrate continuous compliance by using all quality-assured hourly data recorded by the CEMS (or sorbent trap monitoring system) and the other required monitoring systems (e.g., flow rate, CO₂, O₂, or moisture systems) to calculate the arithmetic average emissions rate in units of the standard on a continuous 30-boiler operating day (or, if alternate emissions averaging is used for Hg, 90-boiler operating day) rolling average basis, updated at the end of each new boiler operating day. Use Equation 8 to determine the 30- (or, if applicable, 90-day) boiler operating day rolling average.

$$\text{Boiler operating day average} = \frac{\sum_{i=1}^n (\text{Her}_i)}{n} \quad (\text{Equation 8})$$

Where:

Her_i is the hourly emissions rate for hour *i* and *n* is the number of hourly emissions rate values collected over 30- (or, if applicable, 90-day) boiler operating days.

(c) [N/A - THE EGUs ARE CURRENTLY NOT EQUIPPED WITH A PM CPMS]

(d) If you use quarterly performance testing to demonstrate compliance with one or more applicable emissions limits in Table 2 to 40 CFR Part 63, Subpart UUUUU, you:

(1) May skip performance testing in those quarters during which less than 168 boiler operating hours occur, except that a performance test must be conducted at least once every calendar year.

(2) Must conduct the performance test as defined in Table 5 to 40 CFR Part 63, Subpart UUUUU, and calculate the results of the testing in units of the applicable emissions standard.

(3) [N/A - THE EGUs ARE DEFINED AS COAL-FIRED EGUs]

(e) Conduct periodic performance tune-ups of your EGU(s), as specified in 40 CFR §63.10021(e)(1) through (9), below. For your first tune-up, you may perform the burner inspection any time prior to the tune-up or you may delay the first burner inspection until the next scheduled EGU outage provided you meet the requirements of 40 CFR §63.10005. Subsequently, you must perform an inspection of the burner at least once every 36 calendar months unless your EGU employs neural network combustion optimization during normal operations in which case you must perform an inspection of the burner and combustion controls at least once every 48 calendar months. If your EGU is offline when a deadline to perform the tune-up passes, you shall perform the tune-up work practice requirements within 30 days after the re-start of the affected unit. [NOTE: EGUs DO NOT CURRENTLY EMPLOY NEURAL NETWORK COMBUSTION OPTIMIZATION DURING NORMAL OPERATIONS]

(1) As applicable, inspect the burner and combustion controls and clean or replace any components of the burner or combustion controls as necessary upon initiation of the work practice program and at least once every required inspection period. Repair of a burner or combustion control component requiring special order parts may be scheduled as follows:

**SECTION E. Source Group Restrictions.**

- (i) Burner or combustion control component parts needing replacement that affect the ability to optimize NO_x and CO must be installed within 3 calendar months after the burner inspection,
- (ii) Burner or combustion control component parts that do not affect the ability to optimize NO_x and CO may be installed on a schedule determined by the operator;
- (2) As applicable, inspect the flame pattern and make any adjustments to the burner or combustion controls necessary to optimize the flame pattern. The adjustment should be consistent with the manufacturer's specifications, if available, or in accordance with best combustion engineering practice for that burner type;
- (3) As applicable, observe the damper operations as a function of mill and/or cyclone loadings, cyclone and pulverizer coal feeder loadings, or other pulverizer and coal mill performance parameters, making adjustments and effecting repair to dampers, controls, mills, pulverizers, cyclones, and sensors;
- (4) As applicable, evaluate windbox pressures and air proportions, making adjustments and effecting repair to dampers, actuators, controls, and sensors;
- (5) Inspect the system controlling the air-to-fuel ratio and ensure that it is correctly calibrated and functioning properly. Such inspection may include calibrating excess O₂ probes and/or sensors, adjusting overfire air systems, changing software parameters, and calibrating associated actuators and dampers to ensure that the systems are operated as designed. Any component out of calibration, in or near failure, or in a state that is likely to negate combustion optimization efforts prior to the next tune-up should be corrected or repaired as necessary;
- (6) Optimize combustion to minimize generation of CO and NO_x. This optimization should be consistent with the manufacturer's specifications, if available, or best combustion engineering practice for the applicable burner type. NO_x optimization includes burners, overfire air controls, concentric firing system improvements, neural network or combustion efficiency software, control systems calibrations, adjusting combustion zone temperature profiles, and add-on controls such as SCR and SNCR; CO optimization includes burners, overfire air controls, concentric firing system improvements, neural network or combustion efficiency software, control systems calibrations, and adjusting combustion zone temperature profiles;
- (7) While operating at full load or the predominantly operated load, measure the concentration in the effluent stream of CO and NO_x in ppm, by volume, and oxygen in volume percent, before and after the tune-up adjustments are made (measurements may be either on a dry or wet basis, as long as it is the same basis before and after the adjustments are made). You may use portable CO, NO_x and O₂ monitors for this measurement. EGUs employing neural network optimization systems need only provide a single pre- and post-tune-up value rather than continual values before and after each optimization adjustment made by the system;
- (8) Maintain on-site and submit, if requested by the Administrator, an annual report containing the information in 40 CFR §63.10021(e)(1) through (e)(9), below, including:
- (i) The concentrations of CO and NO_x in the effluent stream in ppm by volume, and oxygen in volume percent, measured before and after an adjustment of the EGU combustion systems;
- (ii) A description of any corrective actions taken as a part of the combustion adjustment; and
- (iii) The type(s) and amount(s) of fuel used over the 12 calendar months prior to an adjustment, but only if the unit was physically and legally capable of using more than one type of fuel during that period; and
- (9) Report the dates of the initial and subsequent tune-ups in hard copy, as specified in 40 CFR §63.10031(f)(5), through June 30, 2020. On or after July 1, 2020, report the date of all tune-ups electronically, in accordance with 40 CFR §63.10031(f). The tune-up report date is the date when tune-up requirements in 40 CFR §63.10021(e)(6) and (7), above, are completed.
- (f) You must submit the reports required under 40 CFR §63.10031 and, if applicable, the reports required under Appendices A and B to 40 CFR Part 63, Subpart UUUUU. The electronic reports required by Appendices A and B to 40 CFR Part 63, Subpart UUUUU, must be sent to the Administrator electronically in a format prescribed by the Administrator as provided in

**SECTION E. Source Group Restrictions.**

40 CFR §63.10031. CEMS data (except for PM CEMS and any approved alternative monitoring using a HAP metals CEMS) shall be submitted using EPA's Emissions Collection and Monitoring Plan System (ECMPS) Client Tool. Other data, including PM CEMS data, HAP metals CEMS data, and CEMS performance test detail reports, shall be submitted in the file format generated through use of EPA's Electronic Reporting Tool, the Compliance and Emissions Data Reporting Interface, or alternate electronic file format, all as provided for under 40 CFR §63.10031.

(g) You must report each instance in which you did not meet an applicable emissions limit or operating limit in Tables 1 through 4 to 40 CFR Part 63, Subpart UUUUU, or failed to conduct a required tune-up. These instances are deviations from the requirements of 40 CFR Part 63, Subpart UUUUU. These deviations must be reported according to 40 CFR §63.10031.

(h) You must follow the startup or shutdown requirements as given in Table 3 to 40 CFR Part 63, Subpart UUUUU, for each coal-fired, liquid oil-fired, or solid oil-derived fuel-fired EGU.

(1) You may use the diluent cap and default gross output values, as described in 40 CFR §63.10007(f), during startup periods or shutdown periods.

(2) You must operate all CMS, collect data, calculate pollutant emission rates, and record data during startup periods or shutdown periods.

(3) You must report the information as required in 40 CFR §63.10031.

(4) [N/A - THE PERMITTEE HAS ALREADY ELECTED TO COMPLY USING PARAGRAPH (1) OF THE DEFINITION OF "STARTUP" IN 40 CFR §63.10042]

(i) You must provide reports as specified in 40 CFR §63.10031 concerning activities and periods of startup and shutdown.

[77 FR 9464, Feb. 16, 2012, as amended at 77 FR 23404, Apr. 19, 2012; 78 FR 24086, Apr. 24, 2013; 79 FR 68791, Nov. 19, 2014; 81 FR 20187, Apr. 6, 2016; 82 FR 16739, Apr. 6, 2017; 83 FR 30883, July 2, 2018]

 Table 7 (Demonstrating Continuous Compliance) to 40 CFR Part 63, Subpart UUUUU - National Emission Standards for Hazardous Air Pollutants: Coal- and Oil-Fired Electric Utility Steam Generating Units

As stated in 40 CFR §63.10021, you must show continuous compliance with the emission limitations for affected sources according to the following:

(1) If you use CEMS to measure filterable PM (FPM), SO₂, HCl, or Hg emissions, or using a sorbent trap monitoring system to measure Hg to meet an applicable emissions limit, you demonstrate continuous compliance by calculating the 30- (or 90-) boiler operating day rolling arithmetic average emissions rate in units of the applicable emissions standard basis at the end of each boiler operating day using all of the quality-assured hourly average CEMS or sorbent trap data for the previous 30- (or 90-) boiler operating days, excluding data recorded during periods of startup or shutdown.

(2) [N/A - THE EGUs ARE CURRENTLY NOT EQUIPPED WITH A PM CPMS]

(3) [N/A - THE EGUs ARE DEFINED AS COAL-FIRED EGUs]

(4) If you use quarterly performance testing for coal-fired, solid oil derived fired, or liquid oil-fired units to measure compliance with one or more non-PM (or its alternative emission limits) applicable emissions limit in Table 1 or 2, or PM (or its alternative emission limits) applicable emissions limit in Table 2 to 40 CFR Part 63, Subpart UUUUU, you demonstrate continuous compliance by calculating the results of the testing in units of the applicable emissions standard.

(5) If you conduct periodic performance tune-ups of your EGU(s) to meet an applicable work practice standard, you demonstrate continuous compliance by conducting periodic performance tune-ups of your EGU(s) as specified in 40 CFR §63.10021(e).

(6) If you use work practice standards for coal-fired, liquid oil-fired, or solid oil-derived fuel-fired EGUs during startup to meet

**SECTION E. Source Group Restrictions.**

an applicable work practice standard, you demonstrate continuous compliance by operating in accordance with Table 3 to 40 CFR Part 63, Subpart UUUUU.

(7) If you use work practice standards for coal-fired, liquid oil-fired, or solid oil-derived fuel-fired EGUs during shutdown to meet an applicable work practice standard, you demonstrate continuous compliance by operating in accordance with Table 3 to 40 CFR Part 63, Subpart UUUUU.

[78 FR 24092, Apr. 24, 2013]

008 [25 Pa. Code §127.511]**Monitoring and related recordkeeping and reporting requirements.**

[Additional authority for this permit condition is also derived from 40 CFR §63.10010 "What are my monitoring, installation, operation, and maintenance requirements?"]

(a) Flue gases from the affected units under 40 CFR Part 63, Subpart UUUUU, exhaust to the atmosphere through a variety of different configurations, including but not limited to, individual stacks, a common stack configuration or a main stack plus a bypass stack. For the CEMS, PM CPMS, and sorbent trap monitoring systems used to provide data under 40 CFR Part 63, Subpart UUUUU, the continuous monitoring system installation requirements for these exhaust configurations are as follows:

(1) Single unit-single stack configurations. For an affected unit that exhausts to the atmosphere through a single, dedicated stack, you shall either install the required CEMS, PM CPMS, and sorbent trap monitoring systems in the stack or at a location in the ductwork downstream of all emissions control devices, where the pollutant and diluent concentrations are representative of the emissions that exit to the atmosphere.

(2) Unit utilizing common stack with other affected unit(s). When an affected unit utilizes a common stack with one or more other affected units, but no non-affected units, you shall either:

(i) Install the required CEMS, PM CPMS, and sorbent trap monitoring systems in the duct leading to the common stack from each unit; or

(ii) Install the required CEMS, PM CPMS, and sorbent trap monitoring systems in the common stack.

(3) [N/A - NONE OF THE EGUs UTILIZE A COMMON STACK WITH A NON-AFFECTED UNIT(S)]

(4) [N/A - NONE OF THE EGUs ARE EQUIPPED WITH A BYPASS STACK]

(5) [N/A - NONE OF THE EGUs DISCHARGE FLUE GASES TO THE ATMOSPHERE THROUGH MULTIPLE STACKS OR ARE FED INTO A SINGLE STACK THROUGH MULTIPLE DUCTS]

(6) [N/A - NONE OF THE EGUs DISCHARGE FLUE GASES TO THE ATMOSPHERE THROUGH MULTIPLE STACKS]

(b) If you use an oxygen (O₂) or carbon dioxide (CO₂) CEMS to convert measured pollutant concentrations to the units of the applicable emissions limit, the O₂ or CO₂ concentrations shall be monitored at a location that represents emissions to the atmosphere (i.e., at the outlet of the EGU) downstream of all emission control devices. You must install, certify, operate, and maintain the CEMS according to 40 CFR Part 75. Use only quality-assured O₂ or CO₂ data in the emissions calculations; do not use 40 CFR Part 75 substitute data values.

(c) If you are required to use a stack gas flow rate monitor, either for routine operation of a sorbent trap monitoring system or to convert pollutant concentrations to units of an electrical output-based emission standard in Table 1 or 2 to 40 CFR Part 63, Subpart UUUUU, you must install, certify, operate, and maintain the monitoring system and conduct on-going quality-assurance testing of the system according to 40 CFR Part 75. Use only unadjusted, quality-assured flow rate data in the emissions calculations. Do not apply bias adjustment factors to the flow rate data and do not use substitute flow rate data in the calculations.

(d) If you are required to make corrections for stack gas moisture content when converting pollutant concentrations to the units of an emission standard in Table 1 or 2 to 40 CFR Part 63, Subpart UUUUU, you must install, certify, operate, and maintain a moisture monitoring system in accordance with 40 CFR Part 75. Alternatively, for coal-fired units, you may use

**SECTION E. Source Group Restrictions.**

appropriate fuel-specific default moisture values from 40 CFR §75.11(b) to estimate the moisture content of the stack gas or you may petition the Administrator under 40 CFR §75.66 for use of a default moisture value for non-coal-fired units [NOTE: THE EGUs ARE DEFINED AS COAL-FIRED EGUs]. If you install and operate a moisture monitoring system, do not use substitute moisture data in the emissions calculations.

(e) [N/A - THE EGUs ARE NOT EQUIPPED WITH HCl AND/OR HF CEMS]

(f) [N/A - THE EGUs ARE NOT EQUIPPED WITH SO₂ CEMS]

(g) If you use a Hg CEMS or a sorbent trap monitoring system, you must install, certify, operate, maintain and quality-assure the data from the monitoring system in accordance with Appendix A to 40 CFR Part 63, Subpart UUUUU. You must calculate and record a 30- (or, if alternate emissions averaging is used, 90-day) boiler operating day rolling average Hg emission rate, in units of the standard, updated after each new boiler operating day. Each 30- (or, if alternate emissions averaging is used, 90-day) boiler operating day rolling average emission rate, calculated according to Section 6.2 of Appendix A to 40 CFR Part 63, Subpart UUUUU, is the average of all of the valid hourly Hg emission rates in the preceding 30- (or, if alternate emissions averaging is used, a 90-day) boiler operating days. Section 7.1.4.3 of Appendix A to 40 CFR Part 63, Subpart UUUUU, explains how to reduce sorbent trap monitoring system data to an hourly basis. [NOTE: THE EGUs CURRENTLY UTILIZE Hg CEMS; A SORBENT TRAP MONITORING SYSTEM IS NOT A CURRENTLY SELECTED COMPLIANCE OPTION]

(h) [N/A - THE EGUs ARE CURRENTLY NOT EQUIPPED WITH A PM CPMS]

(i) [N/A - THE EGUs ARE NOT EQUIPPED WITH PM CEMS]

(j) [N/A - THE EGUs ARE NOT EQUIPPED WITH METAL HAP CEMS]

(k) [N/A - THE EGUs ARE DEFINED AS COAL-FIRED EGUs]

(l) [N/A - THE PERMITTEE HAS ELECTED TO COMPLY USING PARAGRAPH (1) OF THE DEFINITION OF "STARTUP" IN 40 CFR §63.10042]

[77 FR 9464, Feb. 16, 2012, as amended at 77 FR 23404, Apr. 19, 2012; 78 FR 24086, Apr. 24, 2013; 79 FR 68789, Nov. 19, 2014; 81 FR 20185, Apr. 6, 2016]

IV. RECORDKEEPING REQUIREMENTS.**# 009 [25 Pa. Code §127.511]****Monitoring and related recordkeeping and reporting requirements.**

[Additional authority for this permit condition is also derived from 40 CFR §63.10032 "What records must I keep?"]

(a) You must keep records according to 40 CFR §63.10032(a)(1) and (2), below. If you are required to (or elect to) continuously monitor Hg and/or HCl and/or HF emissions, you must also keep the records required under Appendix A and/or Appendix B to 40 CFR Part 63, Subpart UUUUU.

(1) A copy of each notification and report that you submitted to comply with 40 CFR Part 63, Subpart UUUUU, including all documentation supporting any Initial Notification or Notification of Compliance Status or semiannual compliance report that you submitted according to the requirements in 40 CFR §63.10(b)(2)(xiv).

(2) Records of performance stack tests, fuel analyses, or other compliance demonstrations and performance evaluations, as required in 40 CFR §63.10(b)(2)(viii).

(b) For each CEMS and CPMS, you must keep records according to 40 CFR §63.10032(b)(1) through (4), below.

(1) Records described in 40 CFR §63.10(b)(2)(vi) through (xi).

(2) Previous (i.e., superseded) versions of the performance evaluation plan as required in 40 CFR §63.8(d)(3).

(3) Request for alternatives to relative accuracy test for CEMS as required in 40 CFR §63.8(f)(6)(i).

**SECTION E. Source Group Restrictions.**

(4) Records of the date and time that each deviation started and stopped, and whether the deviation occurred during a period of startup, shutdown, or malfunction or during another period.

(c) You must keep the records required in Table 7 to 40 CFR Part 63, Subpart UUUUU, including records of all monitoring data and calculated averages for applicable PM CPMS operating limits to show continuous compliance with each emission limit and operating limit that applies to you.

(d) For each EGU subject to an emission limit, you must also keep the records in 40 CFR §63.10032(d)(1) through (3), below.

(1) You must keep records of monthly fuel use by each EGU, including the type(s) of fuel and amount(s) used.

(2) [N/A - THE EGUs DO NOT COMBUST NON-HAZARDOUS SECONDARY MATERIALS]

(3) For an EGU that qualifies as a LEE under 40 CFR §63.10005(h), you must keep annual records that document that your emissions in the previous performance stack test(s) continue to qualify the unit for LEE status for an applicable pollutant, and document that there was no change in source operations including fuel composition and operation of air pollution control equipment that would cause emissions of the pollutant to increase within the past year.

(e) [N/A - THE PERMITTEE HAS ELECTED TO NOT USE EMISSIONS AVERAGING AS AN ALTERNATIVE TO COMPLYING WITH THE FPM, HCl or Hg EMISSION LIMITS OF 40 CFR §63.9991]

(f) Regarding startup periods or shutdown periods:

(1) Should you choose to rely on paragraph (1) of the definition of "startup" in §63.10042 for your EGU, you must keep records of the occurrence and duration of each startup or shutdown.

(2) [N/A - THE PERMITTEE HAS ALREADY ELECTED TO COMPLY USING PARAGRAPH (1) OF THE DEFINITION OF "STARTUP" IN 40 CFR §63.10042]

(g) You must keep records of the occurrence and duration of each malfunction of an operation (i.e., process equipment) or the air pollution control and monitoring equipment.

(h) You must keep records of actions taken during periods of malfunction to minimize emissions in accordance with 40 CFR §63.10000(b), including corrective actions to restore malfunctioning process and air pollution control and monitoring equipment to its normal or usual manner of operation.

(i) You must keep records of the type(s) and amount(s) of fuel used during each startup or shutdown.

(j) [N/A - THE EGUs ARE DEFINED AS COAL-FIRED EGUs]

[77 FR 9464, Feb. 16, 2012, as amended at 79 FR 68792, Nov. 19, 2014; 81 FR 20189, Apr. 6, 2016]

010 [25 Pa. Code §127.511]**Monitoring and related recordkeeping and reporting requirements.**

[Additional authority for this permit condition is also derived from 40 CFR §63.10033 "In what form and how long must I keep my records?"]

(a) Your records must be in a form suitable and readily available for expeditious review according to 40 CFR §63.10(b)(1).

(b) As specified in 40 CFR §63.10(b)(1), you must keep each record for 5 years following the date of each occurrence, measurement, maintenance, corrective action, report, or record.

(c) You must keep each record on-site for at least 2 years after the date of each occurrence, measurement, maintenance, corrective action, report, or record, according to 40 CFR §63.10(b)(1). You can keep the records off-site for the remaining 3 years.

**SECTION E. Source Group Restrictions.****V. REPORTING REQUIREMENTS.****# 011 [25 Pa. Code §127.511]****Monitoring and related recordkeeping and reporting requirements.**

[Additional authority for this permit condition is also derived from 40 CFR §63.10030 "What notifications must I submit and when?"]

(a) You must submit all of the notifications in 40 CFR §§63.7(b) and (c), 63.8(e), (f)(4) and (6), and 63.9(b) through (h) that apply to you by the dates specified.

(b) As specified in 40 CFR §63.9(b)(2), if you startup your EGU that is an affected source before April 16, 2012, you must submit an Initial Notification not later than 120 days after April 16, 2012. [NOTE: THE INITIAL NOTIFICATION WAS RECEIVED BY BOTH THE DEPARTMENT AND U.S. EPA ON THE DUE DATE OF 8/14/12]

(c) [N/A - THE EGUS ARE DEFINED AS EXISTING EGUS]

(d) When you are required to conduct a performance test, you must submit a Notification of Intent to conduct a performance test at least 30 days before the performance test is scheduled to begin.

(e) When you are required to conduct an initial compliance demonstration as specified in 40 CFR §63.10011(a), you must submit a Notification of Compliance Status according to 40 CFR §63.9(h)(2)(ii). The Notification of Compliance Status report must contain all the information specified in 40 CFR §63.10030(e)(1) through (8), below, as applicable. [NOTE: THE PERMITTEE WAS REQUIRED TO SUBMIT A NOTIFICATION OF COMPLIANCE STATUS (NOCS) BEFORE THE CLOSE OF BUSINESS ON THE 60th DAY FOLLOWING THE COMPLETION OF THE RELEVANT MACT SUBPART UUUUU COMPLIANCE DEMONSTRATION ACTIVITY (i.e., DUE DATE WAS 60 DAYS FOLLOWING THE COMPLETION OF THE FPM & HCI LEE PERFORMANCE TESTING; DUE DATE = 10/16/17); THE PERMITTEE SUBMITTED THE NOCS TO U.S. EPA VIA CEDRI ON 11/13/17]

(f) You must submit the notifications in 40 CFR §63.10000(h)(2) and (i)(2) that may apply to you by the dates specified.

[77 FR 9464, Feb. 16, 2012, as amended at 77 FR 23404, Apr. 19, 2012; 78 FR 24087, Apr. 24, 2013; 79 FR 68791, Nov. 19, 2014; 81 FR 20187, Apr. 6, 2016]

012 [25 Pa. Code §127.511]**Monitoring and related recordkeeping and reporting requirements.**

[Additional authority for this permit condition is also derived from 40 CFR §63.10031 "What reports must I submit and when?"]

(a) You must submit each report in Table 8 to 40 CFR Part 63, Subpart UUUUU, that applies to you. If you are required to (or elect to) continuously monitor Hg and/or HCl and/or HF emissions, you must also submit the electronic reports required under Appendix A and/or Appendix B to 40 CFR Part 63, Subpart UUUUU, at the specified frequency.

(b) Unless the Administrator has approved a different schedule for submission of reports under 40 CFR §63.10(a), you must submit each report by the date in Table 8 to 40 CFR Part 63, Subpart UUUUU, and according to the requirements in 40 CFR §63.10031(b)(1) through (5), below.

(1) The first compliance report must cover the period beginning on the compliance date that is specified for your affected source in 40 CFR §63.9984 and ending on June 30 or December 31, whichever date is the first date that occurs at least 180 days after the compliance date that is specified for your source in 40 CFR §63.9984. [NOTE: THE FIRST SEMI-ANNUAL COMPLIANCE REPORT WAS REQUIRED TO COVER THE PERIOD OF 4/16/16 THROUGH 12/31/16]

(2) The first compliance report must be postmarked or submitted electronically no later than July 31 or January 31, whichever date is the first date following the end of the first calendar half after the compliance date that is specified for your source in 40 CFR §63.9984. [NOTE: THE FIRST SEMI-ANNUAL COMPLIANCE REPORT WAS REQUIRED TO HAVE BEEN POSTMARKED OR SUBMITTED ELECTRONICALLY NO LATER THAN 1/31/17]

[NOTE: THE PERMITTEE SUBMITTED TWO REPORTS THAT COVERED THE FIRST SEMI-ANNUAL COMPLIANCE REPORTING PERIOD OF 4/16/16 THROUGH 12/31/16; THE FIRST OF THE TWO REPORTS COVERED THE PERIOD OF 4/16/16 THROUGH 6/30/16 AND WAS SUBMITTED BY THE PERMITTEE VIA A LETTER DATED 7/21/16 TO U.S. EPA AND

**SECTION E. Source Group Restrictions.**

THE DEPARTMENT (LETTER RECEIVED BY THE DEPARTMENT ON 7/22/16); THE SECOND OF THE TWO REPORTS COVERED THE PERIOD OF 7/01/16 THROUGH 12/31/16 AND WAS SUBMITTED BY THE PERMITTEE VIA A LETTER DATED 1/12/17 TO U.S. EPA AND THE DEPARTMENT (LETTER RECEIVED BY THE DEPARTMENT ON 1/18/17)]

(3) Each subsequent compliance report must cover the semiannual reporting period from January 1 through June 30 or the semiannual reporting period from July 1 through December 31.

(4) Each subsequent compliance report must be postmarked or submitted electronically no later than July 31 or January 31, whichever date is the first date following the end of the semiannual reporting period.

(5) For each affected source that is subject to permitting regulations pursuant to 40 CFR Part 70 or Part 71, and if the permitting authority has established dates for submitting semiannual reports pursuant to 40 CFR §70.6(a)(3)(iii)(A) or 40 CFR §71.6(a)(3)(iii)(A), you may submit the first and subsequent compliance reports according to the dates the permitting authority has established instead of according to the dates in 40 CFR §63.10031(b)(1) through (4), above.

(c) The compliance report must contain the information required in 40 CFR §63.10031(c)(1) through (9), below.

(1) The information required by the summary report located in 40 CFR §63.10(e)(3)(vi).

(2) The total fuel use by each affected source subject to an emission limit, for each calendar month within the semiannual reporting period, including, but not limited to, a description of the fuel, whether the fuel has received a non-waste determination by EPA or your basis for concluding that the fuel is not a waste, and the total fuel usage amount with units of measure.

(3) Indicate whether you burned new types of fuel during the reporting period. If you did burn new types of fuel you must include the date of the performance test where that fuel was in use.

(4) Include the date of the most recent tune-up for each EGU. The date of the tune-up is the date the tune-up provisions specified in §63.10021(e)(6) and (7) were completed.

(5) [N/A - THE PERMITTEE HAS ELECTED TO COMPLY USING PARAGRAPH (1) OF THE DEFINITION OF "STARTUP" IN 40 CFR §63.10042]

(6) You must report emergency bypass information annually from EGUs with LEE status.

(7) A summary of the results of the annual performance tests and documentation of any operating limits that were reestablished during the test, if applicable. If you are conducting stack tests once every 3 years to maintain LEE status, consistent with §63.10006(b), the date of each stack test conducted during the previous 3 years, a comparison of emission level you achieved in each stack test conducted during the previous 3 years to the 50 percent emission limit threshold required in §63.10005(h)(1)(i), and a statement as to whether there have been any operational changes since the last stack test that could increase emissions.

(8) A certification.

(9) If you have a deviation from any emission limit, work practice standard, or operating limit, you must also submit a brief description of the deviation, the duration of the deviation, emissions point identification, and the cause of the deviation.

(d) For each excess emissions occurring at an affected source where you are using a CMS to comply with that emission limit or operating limit, you must include the information required in 40 CFR §63.10(e)(3)(v) in the compliance report specified in 40 CFR §63.10031(c), above.

(e) Each affected source that has obtained a Title V operating permit pursuant to 40 CFR Part 70 or Part 71 must report all deviations as defined in 40 CFR Part 63, Subpart UUUUU, in the semiannual monitoring report required by 40 CFR §70.6(a)(3)(iii)(A) or 40 CFR §71.6(a)(3)(iii)(A). If an affected source submits a compliance report pursuant to Table 8 to 40 CFR Part 63, Subpart UUUUU, along with, or as part of, the semiannual monitoring report required by 40 CFR §70.6(a)(3)(iii)(A) or 40 CFR §71.6(a)(3)(iii)(A), and the compliance report includes all required information concerning deviations from any emission limit, operating limit, or work practice requirement in 40 CFR Part 63, Subpart UUUUU,

**SECTION E. Source Group Restrictions.**

submission of the compliance report satisfies any obligation to report the same deviations in the semiannual monitoring report. Submission of a compliance report does not otherwise affect any obligation the affected source may have to report deviations from operating permit requirements to the permit authority.

(f) On or after July 1, 2020, within 60 days after the date of completing each performance test, you must submit the performance test reports required by 40 CFR Part 63, Subpart UUUUU, to the EPA's WebFIRE database by using the Compliance and Emissions Data Reporting Interface (CEDRI) that is accessed through the U.S. EPA's Central Data Exchange (CDX) (<https://cdx.epa.gov>). Performance test data must be submitted in the file format generated through use of U.S. EPA's Electronic Reporting Tool (ERT) (see <https://www.epa.gov/ttn/chief/ert/index.html>). Only data collected using those test methods on the ERT website are subject to this requirement for submitting reports electronically to WebFIRE. Owners or operators who claim that some of the information being submitted for performance tests is confidential business information (CBI) must submit a complete ERT file including information claimed to be CBI on a compact disk or other commonly used electronic storage media (including, but not limited to, flash drives) to U.S. EPA. The electronic media must be clearly marked as CBI and mailed to U.S. EPA/OAPQS/CORE CBI Office, Attention: WebFIRE Administrator, MD C404-02, 4930 Old Page Rd., Durham, NC 27703. The same ERT file with the CBI omitted must be submitted to U.S. EPA via CDX as described earlier in this paragraph. At the discretion of the delegated authority, you must also submit these reports, including the CBI, to the delegated authority in the format specified by the delegated authority.

(1) On or after July 1, 2020, within 60 days after the date of completing each CEMS (SO₂, PM, HCl, HF, and Hg) performance evaluation test, as defined in 40 CFR §63.2 and required by 40 CFR Part 63, Subpart UUUUU, you must submit the relative accuracy test audit (RATA) data (or, for PM CEMS, RCA and RRA data) required by 40 CFR Part 63, Subpart UUUUU, to U.S. EPA's WebFIRE database by using CEDRI that is accessed through U.S. EPA's CDX (<https://cdx.epa.gov>). The RATA data shall be submitted in the file format generated through use of U.S. EPA's Electronic Reporting Tool (ERT) (<https://www.epa.gov/ttn/chief/ert/index.html>). Only RATA data compounds listed on the ERT website are subject to this requirement. Owners or operators who claim that some of the information being submitted for RATAs is confidential business information (CBI) shall submit a complete ERT file including information claimed to be CBI on a compact disk or other commonly used electronic storage media (including, but not limited to, flash drives) by registered letter to U.S. EPA and the same ERT file with the CBI omitted to U.S. EPA via CDX as described earlier in this paragraph. The compact disk or other commonly used electronic storage media shall be clearly marked as CBI and mailed to U.S. EPA/OAPQS/CORE CBI Office, Attention: WebFIRE Administrator, MD C404-02, 4930 Old Page Rd., Durham, NC 27703. At the discretion of the delegated authority, owners or operators shall also submit these RATAs to the delegated authority in the format specified by the delegated authority. Owners or operators shall submit calibration error testing, drift checks, and other information required in the performance evaluation as described in 40 CFR §63.2 and as required in this chapter (Chapter I).

(2) [N/A - THE EGUs ARE CURRENTLY NOT EQUIPPED WITH A PM CPMS; ALSO, THE EGUs ARE NOT EQUIPPED WITH PM CEMS OR METAL HAP CEMS]

(3) Reports for an SO₂ CEMS, a Hg CEMS or sorbent trap monitoring system, an HCl or HF CEMS, and any supporting monitors for such systems (such as a diluent or moisture monitor) shall be submitted using the ECMPS Client Tool, as provided for in Appendices A and B to this 40 CFR Part 63, Subpart UUUUU, and 40 CFR §63.10021(f). [NOTE: THE EGUs CURRENTLY UTILIZE Hg CEMS; CEMS ARE NOT THE CURRENTLY SELECTED COMPLIANCE OPTION FOR THE OTHER POLLUTANTS]

(4) On or after July 1, 2020, submit the compliance reports required under 40 CFR §63.10031(c) and (d), above, and the notification of compliance status required under 40 CFR §63.10030(e) to the U.S. EPA's WebFIRE database by using the CEDRI that is accessed through the U.S. EPA's CDX (<https://cdx.epa.gov>). You must use the appropriate electronic reporting form in CEDRI or provide an alternate electronic file consistent with U.S. EPA's reporting form output format.

(5) All reports required by 40 CFR Part 63, Subpart UUUUU, not subject to the requirements in 40 CFR §63.10031(f) introductory text, above, and 40 CFR §63.10031(f)(1) through (4), above, must be sent to the Administrator at the appropriate address listed in 40 CFR §63.13. If acceptable to both the Administrator and the owner or operator of an EGU, these reports may be submitted on electronic media. The Administrator retains the right to require submittal of reports subject to 40 CFR §63.10031(f) introductory text, above, and 40 CFR §63.10031(f)(1) through (4), above, in paper format.

(6) Prior to July 1, 2020, all reports subject to electronic submittal in 40 CFR §63.10031(f) introductory text, above, and 40 CFR §63.10031(f)(1), (2), and (4), above, shall be submitted to the U.S. EPA at the frequency specified in those paragraphs

**SECTION E. Source Group Restrictions.**

in electronic portable document format (PDF) using the ECMPs Client Tool. Each PDF version of a submitted report must include sufficient information to assess compliance and to demonstrate that the testing was done properly. The following data elements must be entered into the ECMPs Client Tool at the time of submission of each PDF file:

- (i) The facility name, physical address, mailing address (if different from the physical address), and county;
 - (ii) The ORIS code (or equivalent ID number assigned by U.S. EPA's Clean Air Markets Division (CAMD)) and the Facility Registry System (FRS) ID;
 - (iii) The EGU (or EGUs) to which the report applies. Report the EGU IDs as they appear in the CAMD Business System;
 - (iv) If any of the EGUs in 40 CFR §63.10031(f)(6)(iii), above, share a common stack, indicate which EGUs share the stack. If emissions data are monitored and reported at the common stack according to 40 CFR Part 75, report the ID number of the common stack as it is represented in the electronic monitoring plan required under 40 CFR §75.53;
 - (v) [N/A - THE PERMITTEE HAS ELECTED TO NOT USE EMISSIONS AVERAGING AS AN ALTERNATIVE TO COMPLYING WITH THE FPM, HCl or Hg EMISSION LIMITS OF 40 CFR §63.9991]
 - (vi) The identification of each emission point to which the report applies. An "emission point" is a point at which source effluent is released to the atmosphere, and is either a dedicated stack that serves one of the EGUs identified in 40 CFR §63.10031(f)(6)(iii), above, or a common stack that serves two or more of those EGUs. To identify an emission point, associate it with the EGU or stack ID in the CAMD Business system or the electronic monitoring plan (e.g., "Unit 2 stack," "common stack CS001," or "multiple stack MS001");
 - (vii) The rule citation (e.g., 40 CFR §63.10031(f)(1), 40 CFR §63.10031(f)(2), etc.) for which the report is showing compliance;
 - (viii) The pollutant(s) being addressed in the report;
 - (ix) The reporting period being covered by the report (if applicable);
 - (x) The relevant test method that was performed for a performance test (if applicable);
 - (xi) The date the performance test was conducted (if applicable); and
 - (xii) The responsible official's name, title, and phone number.
- (g) If you had a malfunction during the reporting period, the compliance report must include the number, duration, and a brief description for each type of malfunction which occurred during the reporting period and which caused or may have caused any applicable emission limitation to be exceeded.

[77 FR 9464, Feb. 16, 2012, as amended at 77 FR 23404, Apr. 19, 2012; 79 FR 68791, Nov. 19, 2014; 79 FR 68799, Nov. 19, 2014; 80 FR 15514, Mar. 24, 2015; 81 FR 20188, Apr. 6, 2016; 82 FR 16739, Apr. 6, 2017; 83 FR 30883, July 2, 2018]

Table 8 (Reporting Requirements) to 40 CFR Part 63, Subpart UUUUU - National Emission Standards for Hazardous Air Pollutants: Coal- and Oil-Fired Electric Utility Steam Generating Units

As stated in 40 CFR §63.10031, you must comply with the following requirements for reports:

You must submit a compliance report semiannually according to the requirements in 40 CFR §63.10031(b) that must contain the following:

- (a) Information required in 40 CFR §63.10031(c)(1) through (9); and
- (b) If there are no deviations from any emission limitation (emission limit and operating limit) that applies to you and there

**SECTION E. Source Group Restrictions.**

are no deviations from the requirements for work practice standards in Table 3 to 40 CFR Part 63, Subpart UUUUU, that apply to you, a statement that there were no deviations from the emission limitations and work practice standards during the reporting period. If there were no periods during which the CMSs, including CEMSs and CPMSs, were out-of-control as specified in 40 CFR §63.8(c)(7), a statement that there were no periods during which the CMSs were out-of-control during the reporting period; and

(c) If you have a deviation from any emission limitation (emission limit and operating limit) or work practice standard during the reporting period, the report must contain the information in 40 CFR §63.10031(d). If there were periods during which the CMSs, including CEMSs and CPMSs, were out-of-control, as specified in 40 CFR §63.8(c)(7), the report must contain the information in 40 CFR §63.10031(e)

[81 FR 20201, Apr. 6, 2016]

VI. WORK PRACTICE REQUIREMENTS.

No additional work practice requirements exist except as provided in other sections of this permit including Section B (Title V General Requirements).

VII. ADDITIONAL REQUIREMENTS.**# 013 [25 Pa. Code §127.512]****Operating permit terms and conditions.**

[Additional authority for this permit condition is also derived from 40 CFR §63.10042 "What definitions apply to this subpart?"]

Terms used in 40 CFR Part 63, Subpart UUUUU - National Emission Standards for Hazardous Air Pollutants: Coal- and Oil-Fired Electric Utility Steam Generating Units, as well as Section E, Group 009, are defined in the Clean Air Act; in 40 CFR §63.2 (General Provisions); and in 40 CFR §63.10042.

[77 FR 9464, Feb. 16, 2012, as amended at 77 FR 23405, Apr. 19, 2012; 78 FR 24087, Apr. 24, 2013; 79 FR 68792, Nov. 19, 2014; 81 FR 20189, Apr. 6, 2016]

014 [25 Pa. Code §127.512]**Operating permit terms and conditions.**

[Additional authority for this permit condition is also derived from 40 CFR §63.9980 "What is the purpose of this subpart?"]

40 CFR Part 63, Subpart UUUUU, establishes national emission limitations and work practice standards for hazardous air pollutants (HAPs) emitted from coal- and oil-fired electric utility steam generating units (EGUs) as defined in 40 CFR §63.10042. 40 CFR Part 63, Subpart UUUUU also establishes requirements to demonstrate initial and continuous compliance with the emission limitations.

015 [25 Pa. Code §127.512]**Operating permit terms and conditions.**

[Additional authority for this permit condition is also derived from 40 CFR §63.9981 "Am I subject to this subpart?"]

You are subject to 40 CFR Part 63, Subpart UUUUU, if you own or operate a coal-fired EGU or an oil-fired EGU as defined in 40 CFR §63.10042.

016 [25 Pa. Code §127.512]**Operating permit terms and conditions.**

[Additional authority for this permit condition is also derived from 40 CFR §63.9982 "What is the affected source of this subpart?"]

(a) 40 CFR Part 63, Subpart UUUUU, applies to each individual or group of two or more new, reconstructed, or existing affected source(s) as described in 40 CFR §63.9982(a)(1) and (2) within a contiguous area and under common control.

(1) The affected source of 40 CFR Part 63, Subpart UUUUU, is the collection of all existing coal- or oil-fired EGUs, as defined in 40 CFR §63.10042, within a subcategory.

**SECTION E. Source Group Restrictions.**

(2) [N/A - THE EGUs ARE DEFINED AS EXISTING EGUs]

(b) [N/A - THE EGUs ARE DEFINED AS EXISTING EGUs]

(c) [N/A - THE EGUs ARE DEFINED AS EXISTING EGUs]

(d) An EGU is existing if it is not new or reconstructed. An existing electric steam generating unit that meets the applicability requirements after the effective date of this final rule due to a change in process (e.g., fuel or utilization) is considered to be an existing source under 40 CFR Part 63, Subpart UUUUU.

[77 FR 9464, Feb. 16, 2012, as amended at 77 FR 23402, Apr. 19, 2012; 78 FR 24084, Apr. 24, 2013]

017 [25 Pa. Code §127.512]

Operating permit terms and conditions.

In the event that 40 CFR Part 63, Subpart UUUUU - National Emission Standards for Hazardous Air Pollutants: Coal- and Oil-Fired Electric Utility Steam Generating Units (MACT Subpart UUUUU) is revised, the permittee shall comply with the revised version of MACT Subpart UUUUU, and shall not be required to comply with any provisions in this operating permit designated as having MACT Subpart UUUUU as their authority, to the extent that such operating permit provisions would be inconsistent with the applicable provisions of the revised MACT Subpart UUUUU. In the event of any changes to MACT Subpart UUUUU, the Department may require the permittee to submit an application for an operating permit modification pursuant to 25 Pa. Code §127.463.

018 [25 Pa. Code §127.512]

Operating permit terms and conditions.

[Additional authority for this permit condition is also derived from 40 CFR §63.9984 "When do I have to comply with this subpart?"]

(a) [N/A - THE EGUs ARE DEFINED AS EXISTING EGUs]

(b) If you have an existing EGU, you must comply with 40 CFR Part 63, Subpart UUUUU, no later than April 16, 2015. [NOTE: THE PERMITTEE REQUESTED A 1-YEAR MACT SUBPART UUUUU COMPLIANCE DATE EXTENSION FOR MERCURY REQUIREMENTS VIA LETTERS DATED 6/27/13 & 10/10/13; THE DEPARTMENT APPROVED THIS COMPLIANCE DATE EXTENSION REQUEST VIA A LETTER DATED 10/31/13; THEREFORE, THE PERMITTEE'S RELEVANT MACT SUBPART UUUUU COMPLIANCE DATE FOR MERCURY REQUIREMENTS WAS 4/16/16]

(c) You must meet the notification requirements in 40 CFR §63.10030 according to the schedule in 40 CFR §63.10030 and in Subpart A of 40 CFR Part 63, Subpart UUUUU. Some of the notifications must be submitted before you are required to comply with the emission limits and work practice standards in 40 CFR Part 63, Subpart UUUUU.

(d) [N/A - THE BOILERS CURRENTLY MEET THE DEFINITION OF AN EGU SUBJECT TO 40 CFR PART 63, SUBPART UUUUU]

(e) [N/A - THE EGUs ARE NOT EXEMPTED FROM 40 CFR PART 63, SUBPART UUUUU, UNDER 40 CFR §63.9983(d)]

(f) You must demonstrate that compliance has been achieved by conducting the required performance tests and other activities no later than 180 days after the applicable date in 40 CFR §63.9984(b)&(c), above.

019 [25 Pa. Code §127.512]

Operating permit terms and conditions.

[Additional authority for this permit condition is also derived from 40 CFR §63.9990 "What are the subcategories of EGUs?"]

(a) Coal-fired EGUs are subcategorized as defined in 40 CFR §63.9990(a)(1) through (a)(2), below, and as defined in 40 CFR §63.10042.

(1) EGUs designed for coal with a heating value greater than or equal to 8,300 Btu/lb, and

(2) [N/A - THE EGUs ARE NOT DESIGNED FOR LOW RANK VIRGIN COAL]

**SECTION E. Source Group Restrictions.**

(b) [N/A - THE EGUs ARE CURRENTLY DEFINED AS COAL-FIRED EGUs]

(c) [N/A - THE EGUs DO NOT MEET THE DEFINITION OF AN IGCC]

020 [25 Pa. Code §127.512]

Operating permit terms and conditions.

[Additional authority for this permit condition is also derived from 40 CFR §63.10000 "What are my general requirements for complying with this subpart?"]

(a) You must be in compliance with the emission limits and operating limits in 40 CFR Part 63, Subpart UUUUU. These limits apply to you at all times except during periods of startup and shutdown; however, for coal-fired, liquid oil-fired, or solid oil-derived fuel-fired EGUs, you are required to meet the work practice requirements, Item Nos. 3 and 4, in Table 3 to 40 CFR Part 63, Subpart UUUUU, during periods of startup or shutdown.

(b) At all times you must operate and maintain any affected source, including associated air pollution control equipment and monitoring equipment, in a manner consistent with safety and good air pollution control practices for minimizing emissions. Determination of whether such operation and maintenance procedures are being used will be based on information available to the U.S. EPA Administrator which may include, but is not limited to, monitoring results, review of operation and maintenance procedures, review of operation and maintenance records, and inspection of the source.

(c)(1) For coal-fired units, IGCC units, and solid oil-derived fuel-fired units, initial performance testing is required for all pollutants to demonstrate compliance with the applicable emissions limits.

(i) For a coal-fired or solid oil-derived fuel-fired EGU or IGCC EGU, you may conduct initial performance testing in accordance with 40 CFR §63.10005(h), to determine whether the EGU qualifies as a low emitting EGU (LEE) for one or more applicable emission limits, except as otherwise provided in paragraphs (c)(1)(i)(A) and (B), below:

(A) [N/A - NONE OF THE EGUs ARE EQUIPPED WITH A BYPASS STACK]

(B) [N/A - THE EGUs ARE DEFINED AS EXISTING EGUs]

(C) [N/A - NONE OF THE EGUs ARE EQUIPPED WITH A BYPASS STACK]

(ii) [N/A - THE PERMITTEE HAS CURRENTLY ELECTED TO NOT SEEK Hg LEE STATUS]

(iii) For a qualifying LEE of any other applicable emissions limits, you must conduct a performance test at least once every 36 calendar months to demonstrate continued LEE status.

(iv) [N/A - THE EGUs HAVE ACHIEVED FPM LEE STATUS]

(v) [N/A - THE EGUs HAVE ACHIEVED HCl LEE STATUS]

(vi) If your coal-fired or solid oil-derived fuel-fired EGU does not qualify as a LEE for Hg, you must demonstrate initial and continuous compliance through use of a Hg CEMS or a sorbent trap monitoring system in accordance with Appendix A to 40 CFR Part 63, Subpart UUUUU..

(A) [N/A - NONE OF THE EGUs ARE CURRENTLY EQUIPPED WITH A SORBENT TRAP MONITORING SYSTEM]

(B) [N/A - NONE OF THE EGUs ARE CURRENTLY EQUIPPED WITH A SORBENT TRAP MONITORING SYSTEM]

(2) [N/A - THE EGUs ARE DEFINED AS COAL-FIRED EGUs]

(d)(1) If you demonstrate compliance with any applicable emissions limit through use of a continuous monitoring system (CMS), where a CMS includes a continuous parameter monitoring system (CPMS) as well as a continuous emissions monitoring system (CEMS), you must develop a site-specific monitoring plan and submit this site-specific monitoring plan, if requested, at least 60 days before your initial performance evaluation (where applicable) of your CMS. This requirement also applies to you if you petition the Administrator for alternative monitoring parameters under 40 CFR §63.8(f). This requirement to develop and submit a site-specific monitoring plan does not apply to affected sources with existing

**SECTION E. Source Group Restrictions.**

monitoring plans that apply to CEMS and CPMS prepared under Appendix B to 40 CFR Part 60 or 40 CFR Part 75, and that meet the requirements of 40 CFR §63.10010. Using the process described in 40 CFR §63.8(f)(4), you may request approval of monitoring system quality assurance and quality control procedures alternative to those specified in 40 CFR §63.10000(d) and, if approved, include those in your site-specific monitoring plan. The monitoring plan must address the provisions in 40 CFR §63.10000(d)(2) through (5), below.

(2) The site-specific monitoring plan shall include the information specified in 40 CFR §63.10000(d)(5)(i) through (d)(5)(vii), below. Alternatively, the requirements of 40 CFR §63.10000(d)(5)(i) through (d)(5)(vii) are considered to be met for a particular CMS or sorbent trap monitoring system if:

(i) The CMS or sorbent trap monitoring system is installed, certified, maintained, operated, and quality-assured either according to 40 CFR Part 75, or Appendix A or B to 40 CFR Part 63, Subpart UUUUU; and

(ii) The record keeping and reporting requirements of 40 CFR Part 75, or Appendix A or B to 40 CFR Part 63, Subpart UUUUU, that pertain to the CMS are met.

(3) If requested by the Administrator, you must submit the monitoring plan (or relevant portion of the plan) at least 60 days before the initial performance evaluation of a particular CMS, except where the CMS has already undergone a performance evaluation that meets the requirements of 40 CFR §63.10010 (e.g., if the CMS was previously certified under another program).

(4) You must operate and maintain the CMS according to the site-specific monitoring plan.

(5) The provisions of the site-specific monitoring plan must address the following items:

(i) Installation of the CMS or sorbent trap monitoring system sampling probe or other interface at a measurement location relative to each affected process unit such that the measurement is representative of control of the exhaust emissions (e.g., on or downstream of the last control device). See 40 CFR §63.10010(a) for further details. For PM/CPMS installations, follow the procedures in 40 CFR §63.10010(h).

(ii) Performance and equipment specifications for the sample interface, the pollutant concentration or parametric signal analyzer, and the data collection and reduction systems.

(iii) Schedule for conducting initial and periodic performance evaluations.

(iv) Performance evaluation procedures and acceptance criteria (e.g., calibrations), including the quality control program in accordance with the general requirements of 40 CFR §63.8(d).

(v) On-going operation and maintenance procedures, in accordance with the general requirements of 40 CFR §§63.8(c)(1)(ii), (c)(3), and (c)(4)(ii).

(vi) Conditions that define a CMS that is out of control consistent with 40 CFR §63.8(c)(7)(i) and for responding to out of control periods consistent with 40 CFR §§63.8(c)(7)(ii) and (c)(8).

(vii) On-going record keeping and reporting procedures, in accordance with the general requirements of 40 CFR §§63.10(c), (e)(1), and (e)(2)(i), or as specifically required under 40 CFR Part 63, Subpart UUUUU.

(e) As part of your demonstration of continuous compliance, you must perform periodic tune-ups of your EGU(s), according to 40 CFR §63.10021(e).

(f) Except as provided under 40 CFR §63.10000(n), below, you are subject to the requirements of 40 CFR Part 63, Subpart UUUUU, for at least 6 months following the last date you met the definition of an EGU subject to this subpart (e.g., 6 months after a cogeneration unit provided more than one third of its potential electrical output capacity and more than 25 megawatts electrical output to any power distribution system for sale). You may opt to remain subject to the provisions of 40 CFR Part 63, Subpart UUUUU beyond 6 months after the last date you met the definition of an EGU subject to 40 CFR Part 63, Subpart UUUUU, unless you are a solid waste incineration unit subject to standards under CAA Section 129 (e.g., 40 CFR Part 60, Subpart CCCC (New Source Performance Standards (NSPS) for Commercial and Industrial Solid Waste

**SECTION E. Source Group Restrictions.**

Incineration Units, or 40 CFR Part 60, Subpart DDDD (Emissions Guidelines (EG) for Existing Commercial and Industrial Solid Waste Incineration Units))). Notwithstanding the provisions of 40 CFR Part 63, Subpart UUUUU, an EGU that starts combusting solid waste is immediately subject to standards under CAA Section 129 and the EGU remains subject to those standards until the EGU no longer meets the definition of a solid waste incineration unit consistent with the provisions of the applicable CAA Section 129 standards.

(g) Except as provided under 40 CFR §63.10000(n), below, if your unit no longer meets the definition of an EGU subject to 40 CFR Part 63, Subpart UUUUU, you must be in compliance with any newly applicable standards on the date you are no longer subject to 40 CFR Part 63, Subpart UUUUU. The date you are no longer subject to 40 CFR Part 63, Subpart UUUUU, is a date selected by you, that must be at least 6 months from the date that you last met the definition of an EGU subject to 40 CFR Part 63, Subpart UUUUU, or the date you begin combusting solid waste, consistent with 40 CFR §63.9983(d). Your source must remain in compliance with 40 CFR Part 63, Subpart UUUUU, until the date you select to cease complying with 40 CFR Part 63, Subpart UUUUU, or the date you begin combusting solid waste, whichever is earlier.

(h) [N/A - THE EGUS ARE DEFINED AS EXISTING EGUS AND WERE SUBJECT TO 40 CFR PART 63, SUBPART UUUUU, ON 4/16/15]

(i)(1) If you own or operate an EGU subject to 40 CFR Part 63, Subpart UUUUU, and cease to operate in a manner that causes your unit to meet the definition of an EGU subject to 40 CFR Part 63, Subpart UUUUU, you must be in compliance with any newly applicable Section 112 or 129 standards on the date you selected consistent with 40 CFR §63.10000(g), above, and 40 CFR §63.10000(n), below.

(2) You must provide 30 days prior notice of the date your EGU will cease complying with 40 CFR Part 63, Subpart UUUUU. The notification must identify:

(i) The name of the owner or operator of the EGU(s), the location of the facility, the EGU(s) that will cease complying with 40 CFR Part 63, Subpart UUUUU, and the date of the notice;

(ii) The currently applicable subcategory under 40 CFR Part 63, Subpart UUUUU, and any 40 CFR Part 60, Part 62, or Part 63 subpart and subcategory that will be applicable after you cease complying with 40 CFR Part 63, Subpart UUUUU;

(iii) The date on which you became subject to 40 CFR Part 63, Subpart UUUUU;

(iv) The date upon which you will cease complying with 40 CFR Part 63, Subpart UUUUU, consistent with 40 CFR §63.10000(g).

(j) All air pollution control equipment necessary for compliance with any newly applicable emissions limits which apply as a result of the cessation or commencement or recommencement of operations that cause your EGU to meet the definition of an EGU subject to 40 CFR Part 63, Subpart UUUUU, must be installed and operational as of the date your source ceases to be or becomes subject to 40 CFR Part 63, Subpart UUUUU.

(k) All monitoring systems necessary for compliance with any newly applicable monitoring requirements which apply as a result of the cessation or commencement or recommencement of operations that cause your EGU to meet the definition of an EGU subject to 40 CFR Part 63, Subpart UUUUU, must be installed and operational as of the date your source ceases to be or becomes subject to 40 CFR Part 63, Subpart UUUUU. All calibration and drift checks must be performed as of the date your source ceases to be or becomes subject to 40 CFR Part 63, Subpart UUUUU. You must also comply with provisions of 40 CFR §§63.10010, 63.10020, and 63.10021. Relative accuracy tests must be performed as of the performance test deadline for PM CEMS, if applicable. Relative accuracy testing for other CEMS need not be repeated if that testing was previously performed consistent with CAA Section 112 monitoring requirements or monitoring requirements under 40 CFR Part 63, Subpart UUUUU.

(l) [N/A - THE EGUS ARE CURRENTLY NOT EQUIPPED WITH A PM CPMS; ALSO, THE EGUS ARE NOT EQUIPPED WITH PM CEMS OR NON-Hg METAL HAP CEMS]

(m) [N/A - THE PERMITTEE HAS ELECTED TO COMPLY USING PARAGRAPH (1) OF THE DEFINITION OF "STARTUP" IN 40 CFR §63.10042]

**SECTION E. Source Group Restrictions.**

(n) If you have permanently converted your EGU from coal or oil to natural gas or biomass after your compliance date (or, if applicable, after your approved extended compliance date), as demonstrated by being subject to a permit provision or physical limitation (including retirement) that prevents you from operating in a manner that would subject you to 40 CFR Part 63, Subpart UUUUU, you are no longer subject to 40 CFR Part 63, Subpart UUUUU, notwithstanding the coal or oil usage in the previous calendar years. The date on which you are no longer subject to 40 CFR Part 63, Subpart UUUUU, is the date on which you converted to natural gas or biomass firing; it is also the date on which you must be in compliance with any newly applicable standards.

[77 FR 9464, Feb. 16, 2012, as amended at 77 FR 23402, Apr. 19, 2012; 78 FR 24084, Apr. 24, 2013; 79 FR 68788, Nov. 19, 2014; 81 FR 20180, Apr. 6, 2016]

021 [25 Pa. Code §127.512]**Operating permit terms and conditions.**

[Additional authority for this permit condition is also derived from 40 CFR §63.10040 "What parts of the General Provisions apply to me?"]

Table 9 to 40 CFR Part 63, Subpart UUUUU, shows which parts of the General Provisions in 40 CFR §§63.1 through 63.15 apply to you.

022 [25 Pa. Code §127.512]**Operating permit terms and conditions.**

[Additional authority for this permit condition is also derived from 40 CFR §63.10011 "How do I demonstrate initial compliance with the emissions limits and work practice standards?"]

(a) You must demonstrate initial compliance with each emissions limit that applies to you by conducting performance testing.

(b) [N/A - THE EGUs ARE CURRENTLY NOT EQUIPPED WITH A PM CPMS; THEREFORE, THE TABLE 4 OPERATING LIMITS ARE NOT APPLICABLE]

(c)(1) If you use CEMS or sorbent trap monitoring systems to measure a HAP (e.g., Hg or HCl) directly, the initial performance test shall consist of a 30-boiler operating day (or, for certain coal-fired, existing EGUs that use emissions averaging for Hg, a 90-boiler operating day) rolling average emissions rate obtained with a certified CEMS or sorbent trap system, expressed in units of the standard. If the monitoring system is certified prior to the applicable compliance date, the initial averaging period shall either begin with: The first boiler operating day on or after the compliance date; or 30 (or, if applicable, 90) boiler operating days prior to that date, as described in 40 CFR §63.10005(b). In all cases, the initial 30- or 90-boiler operating day averaging period must be completed on or before the date that compliance must be demonstrated, in accordance with 40 CFR §63.9984(f). Initial compliance is demonstrated if the results of the performance test meet the applicable emission limit in Table 1 or 2 to 40 CFR Part 63, Subpart UUUUU. [NOTE: TABLE 1 TO 40 CFR PART 63, SUBPART UUUUU, IS NOT APPLICABLE]

(2) [N/A - THE EGUs ARE NOT EQUIPPED WITH SO2 OR FPM CEMS]

(d) For candidate LEE units, use the results of the performance testing described in 40 CFR §63.10005(h) to determine initial compliance with the applicable emission limit(s) in Table 1 or 2 to 40 CFR Part 63, Subpart UUUUU, and to determine whether the unit qualifies for LEE status. [NOTE: THE EGUs HAVE ACHIEVED LEE STATUS FOR FPM & HCl]

(e) You must submit a Notification of Compliance Status containing the results of the initial compliance demonstration, in accordance with 40 CFR §63.10030(e). [NOTE: THE PERMITTEE SUBMITTED THE NOTIFICATION OF COMPLIANCE STATUS TO U.S. EPA VIA CEDRI ON 11/13/17]

(f)(1) You must determine the fuel whose combustion produces the least uncontrolled emissions (i.e., the cleanest fuel, either natural gas or distillate oil) that is available on-site or accessible nearby for use during periods of startup or shutdown.

(2) Your cleanest fuel, either natural gas or distillate oil, for use during periods of startup or shutdown determination may take safety considerations into account.

**SECTION E. Source Group Restrictions.**

(g) You must follow the startup or shutdown requirements as established in Table 3 to 40 CFR Part 63, Subpart UUUUU, for each coal-fired, liquid oil-fired, or solid oil-derived fuel-fired EGU.

(1) You may use the diluent cap and default gross output values, as described in 40 CFR §63.10007(f), during startup periods or shutdown periods.

(2) You must operate all CMS, collect data, calculate pollutant emission rates, and record data during startup periods and shutdown periods.

(3) You must report the information as required in 40 CFR §63.10031.

(4) [N/A - THE PERMITTEE HAS ALREADY ELECTED TO COMPLY USING PARAGRAPH (1) OF THE DEFINITION OF "STARTUP" IN 40 CFR §63.10042]

[77 FR 9464, Feb. 16, 2012, as amended at 77 FR 23404, Apr. 19, 2012; 79 FR 68790, Nov. 19, 2014; 81 FR 20186, Apr. 6, 2016]

023 [25 Pa. Code §127.512]**Operating permit terms and conditions.**

[Additional authority for this permit condition is also derived from 40 CFR §63.10041 "Who implements and enforces this subpart?"]

(a) 40 CFR Part 63, Subpart UUUUU, can be implemented and enforced by U.S. EPA, or a delegated authority such as your state, local, or tribal agency. If the EPA Administrator has delegated authority to your state, local, or tribal agency, then that agency (as well as the U.S. EPA) has the authority to implement and enforce 40 CFR Part 63, Subpart UUUUU. You should contact your EPA Regional Office to find out if 40 CFR Part 63, Subpart UUUUU, is delegated to your state, local, or tribal agency.

(b) In delegating implementation and enforcement authority of 40 CFR Part 63, Subpart UUUUU, to a state, local, or tribal agency under 40 CFR Part 63, Subpart E, the authorities listed in 40 CFR §63.10041(b)(1) through (4), below, are retained by the EPA Administrator and are not transferred to the state, local, or tribal agency; moreover, the U.S. EPA retains oversight of 40 CFR Part 63, Subpart UUUUU, and can take enforcement actions, as appropriate, with respect to any failure by any person to comply with any provision of 40 CFR Part 63, Subpart UUUUU.

(1) Approval of alternatives to the non-opacity emission limits and work practice standards in 40 CFR §63.9991(a) and (b) under 40 CFR §63.6(g).

(2) Approval of major changes to test methods in Table 5 to 40 CFR Part 63, Subpart UUUUU, under 40 CFR §63.7(e)(2)(ii) and (f) and as defined in 40 CFR §63.90, approval of minor and intermediate changes to monitoring performance specifications/procedures in Table 5 where the monitoring serves as the performance test method (see definition of "test method" in 40 CFR §63.2).

(3) Approval of major changes to monitoring under 40 CFR §63.8(f) and as defined in 40 CFR §63.90.

(4) Approval of major change to recordkeeping and reporting under 40 CFR §63.10(e) and as defined in 40 CFR §63.90.

024 [25 Pa. Code §127.512]**Operating permit terms and conditions.**

Section E (Group 009) of this operating permit outlines the compliance options currently selected by the permittee. Nothing in this operating permit precludes the permittee from selecting alternate compliance options as allowed by 40 CFR 63, Subpart UUUUU.

025 [40 CFR Part 63 NESHAPS for Source Categories §40 CFR 63.1]**Subpart A--General Provisions****Applicability.**

The Group 009 boilers are subject to 40 CFR Part 63, Subpart UUUUU - National Emission Standards for Hazardous Air Pollutants: Coal- and Oil-Fired Electric Utility Steam Generating Units. The permittee shall comply with all applicable standards, compliance provisions, performance test, monitoring, record keeping, and reporting requirements contained at

**SECTION E. Source Group Restrictions.**

40 CFR §§63.9980 through 63.10042, including all applicable portions of 40 CFR Part 63, Subpart A - General Provisions. The permittee shall comply with 40 CFR §63.13(a), which requires submission of copies of all requests, reports, applications, submittals, and other communications to both the U.S. Environmental Protection Agency (U.S. EPA) and the Department. The U.S. EPA copies shall be forwarded to:

Director
Air Protection Division
U.S. EPA, Region III (3AP00)
1650 Arch Street
Philadelphia, PA 19103-2029

The Department copies shall be forwarded to:

Regional Air Program Manager
PA Department of Environmental Protection
909 Elmerton Avenue
Harrisburg, PA 17110-8200

***** Permit Shield in Effect. *****

**SECTION E. Source Group Restrictions.**

Group Name: GROUP 010

Group Description: Sources Subject to NSPS Subpart IIII

Sources included in this group

ID	Name
037	DIESEL- FIRED QUENCH PUMP 1
038	DIESEL- FIRED QUENCH PUMP 2

I. RESTRICTIONS.**Emission Restriction(s).****# 001 [40 CFR Part 60 Standards of Performance for New Stationary Sources §40 CFR 60.4205]****Subpart IIII - Standards of Performance for Stationary Compression Ignition Internal Combustion Engines****What emission standards must I meet for emergency engines if I am an owner or operator of a stationary CI internal combustion engine?**

(a) [N/A - THE STATIONARY CI ICEs ARE MODEL YEAR 2007 UNITS AND ARE FIRE PUMP ENGINES]

(b) [N/A - THE STATIONARY CI ICEs ARE FIRE PUMP ENGINES]

(c) Owners and operators of fire pump engines with a displacement of less than 30 liters per cylinder must comply with the emission standards in Table 4 to 40 CFR Part 60, Subpart IIII, for all pollutants. [NOTE: THE FIRE PUMP ENGINES EACH HAVE A DISPLACEMENT OF LESS THAN 30 LITERS PER CYLINDER (i.e., 1.1 LITER/CYLINDER); TABLE 4 TO SUBPART IIII OF PART 60 (EMISSION STANDARDS FOR STATIONARY FIRE PUMP ENGINES) LISTS THE FOLLOWING APPLICABLE EMISSION STANDARDS IN UNITS OF g/kW-hr (g/bhp-hr): NMHC + NOx = 10.5 (7.8); CO = 3.5 (2.6); and PM = 0.54 (0.40); THE AFOREMENTIONED CO EMISSION STANDARD IS SUPERSEDED BY THE BAT CO EMISSION STANDARD OF CONDITION #002(a)(2) OF GROUP 005 IN SECTION E]

(d) [N/A - THE STATIONARY CI ICEs HAVE A DISPLACEMENT OF LESS THAN 30 LITERS PER CYLINDER]

(e) Owners and operators of emergency stationary CI ICE with a displacement of less than 30 liters per cylinder who conduct performance tests in-use must meet the NTE standards as indicated in 40 CFR §60.4212.

(f) [N/A - THE STATIONARY CI ICEs ARE NOT MODIFIED OR RECONSTRUCTED CI ICEs]

[71 FR 39172, July 11, 2006, as amended at 76 FR 37969, June 28, 2011]

002 [40 CFR Part 60 Standards of Performance for New Stationary Sources §40 CFR 60.4206]**Subpart IIII - Standards of Performance for Stationary Compression Ignition Internal Combustion Engines****How long must I meet the emission standards if I am an owner or operator of a stationary CI internal combustion engine?**

Owners and operators of stationary CI ICEs must operate and maintain stationary CI ICEs that achieve the emission standards as required in 40 CFR §§60.4204 and 60.4205 over the entire life of the engine.

[76 FR 37969, June 28, 2011]

Fuel Restriction(s).**# 003 [40 CFR Part 60 Standards of Performance for New Stationary Sources §40 CFR 60.4207]****Subpart IIII - Standards of Performance for Stationary Compression Ignition Internal Combustion Engines****What fuel requirements must I meet if I am an owner or operator of a stationary CI internal combustion engine subject to 40 CFR 60.4207?**

(a) [N/A - SUPERSEDED BY 40 CFR §60.4207(b), BELOW]

(b) Beginning October 1, 2010, owners and operators of stationary CI ICE subject to 40 CFR Part 63, Subpart IIII, with a displacement of less than 30 liters per cylinder that use diesel fuel must use diesel fuel that meets the requirements of 40 CFR §80.510(b) for nonroad diesel fuel, except that any existing diesel fuel purchased (or otherwise obtained) prior to October 1, 2010, may be used until depleted.

[NOTE: 40 CFR §80.510(b) STATES THAT EXCEPT AS OTHERWISE SPECIFICALLY PROVIDED IN 40 CFR PART 80, SUBPART I, ALL NONROAD DIESEL FUEL IS SUBJECT TO THE FOLLOWING PER-GALLON STANDARDS: SULFUR CONTENT MAXIMUM OF 15 PPM (0.0015% (by weight)); AND A MINIMUM CETANE INDEX OF 40, OR A MAXIMUM AROMATIC

**SECTION E. Source Group Restrictions.**

CONTENT OF 35% (by volume)]

(c) [Reserved]

(d) [N/A - THE STATIONARY CI ICEs HAVE A DISPLACEMENT OF LESS THAN 30 LITERS PER CYLINDER]

(e) [N/A - THE STATIONARY CI ICEs DO NOT HAVE A NATIONAL SECURITY EXEMPTION UNDER 40 CFR §60.4200(d)]

[71 FR 39172, July 11, 2006, as amended at 76 FR 37969, June 28, 2011; 78 FR 6695, Jan. 30, 2013]

II. TESTING REQUIREMENTS.

No additional testing requirements exist except as provided in other sections of this permit including Section B (Title V General Requirements).

III. MONITORING REQUIREMENTS.

**# 004 [40 CFR Part 60 Standards of Performance for New Stationary Sources §40 CFR 60.4209]
Subpart III - Standards of Performance for Stationary Compression Ignition Internal Combustion Engines
What are the monitoring requirements if I am an owner or operator of a stationary CI internal combustion engine?**

If you are an owner or operator, you must meet the monitoring requirements of 40 CFR §60.4209. In addition, you must also meet the monitoring requirements specified in 40 CFR §60.4211.

(a) If you are an owner or operator of an emergency stationary CI internal combustion engine that does not meet the standards applicable to non-emergency engines, you must install a non-resettable hour meter prior to startup of the engine.

(b) [THE STATIONARY CI ICEs ARE NOT EQUIPPED WITH A DIESEL PARTICULATE FILTER]

[71 FR 39172, July 11, 2006, as amended at 76 FR 37969, June 28, 2011]

IV. RECORDKEEPING REQUIREMENTS.

**# 005 [40 CFR Part 60 Standards of Performance for New Stationary Sources §40 CFR 60.4214]
Subpart III - Standards of Performance for Stationary Compression Ignition Internal Combustion Engines
What are my notification, reporting, and recordkeeping requirements if I am an owner or operator of a stationary CI internal combustion engine?**

(a) [N/A - THE STATIONARY CI ICEs ARE EMERGENCY UNITS]

(b) If the stationary CI internal combustion engine is an emergency stationary internal combustion engine, the owner or operator is not required to submit an initial notification. Starting with the model years in Table 5 to 40 CFR Part 60, Subpart III, if the emergency engine does not meet the standards applicable to non-emergency engines in the applicable model year, the owner or operator must keep records of the operation of the engine in emergency and non-emergency service that are recorded through the non-resettable hour meter. The owner must record the time of operation of the engine and the reason the engine was in operation during that time. [NOTE: THE STATIONARY CI ICEs ARE MODEL YEAR 2007 UNITS; TABLE 5 TO 40 CFR PART 60, SUBPART III, STARTS WITH MODEL YEAR 2011; THEREFORE, THE OWNER OR OPERATOR IS NOT REQUIRED TO KEEP RECORDS OF THE OPERATION OF THE ICE IN EMERGENCY AND NON-EMERGENCY SERVICE THAT ARE RECORDED THROUGH THE NON-RESETTABLE HOUR METER]

(c) [N/A - THE STATIONARY CI ICEs ARE NOT EQUIPPED WITH A DIESEL PARTICULATE FILTER]

(d) If you own or operate an emergency stationary CI ICE with a maximum engine power more than 100 HP that operates or is contractually obligated to be available for more than 15 hours per calendar year for the purposes specified in 40 CFR §60.4211(f)(2)(ii) and (iii) or that operates for the purposes specified in 40 CFR §60.4211(f)(3)(i), you must submit an annual report according to the requirements in 40 CFR §60.4214(d)(1) through (3), below. [NOTE: 40 CFR §60.4211(f)(2)(ii)&(iii) WERE VACATED AS OF MAY 2, 2016 PER COURT ORDER]

(1) The report must contain the following information:

**SECTION E. Source Group Restrictions.**

- (i) Company name and address where the engine is located.
 - (ii) Date of the report and beginning and ending dates of the reporting period.
 - (iii) Engine site rating and model year.
 - (iv) Latitude and longitude of the engine in decimal degrees reported to the fifth decimal place.
 - (v) [N/A - 40 CFR §60.4211(f)(2)(ii)&(iii) WERE VACATED AS OF MAY 2, 2016 PER COURT ORDER]
 - (vi) [N/A - 40 CFR §60.4211(f)(2)(ii)&(iii) WERE VACATED AS OF MAY 2, 2016 PER COURT ORDER]
 - (vii) Hours spent for operation for the purposes specified in 40 CFR §60.4211(f)(3)(i), including the date, start time, and end time for engine operation for the purposes specified in 40 CFR §60.4211(f)(3)(i). The report must also identify the entity that dispatched the engine and the situation that necessitated the dispatch of the engine.
- (2) The first annual report must cover the calendar year 2015 and must be submitted no later than March 31, 2016. Subsequent annual reports for each calendar year must be submitted no later than March 31 of the following calendar year.
- (3) The annual report must be submitted electronically using the 40 CFR Part 60, Subpart III-specific reporting form in the Compliance and Emissions Data Reporting Interface (CEDRI) that is accessed through EPA's Central Data Exchange (CDX) (www.epa.gov/cdx). However, if the reporting form specific to 40 CFR Subpart III, is not available in CEDRI at the time that the report is due, the written report must be submitted to the Administrator at the appropriate address listed in 40 CFR §60.4.
- (e) [N/A - THE STATIONARY CI ICEs ARE NOT EQUIPPED WITH AUXILIARY EMISSION CONTROL DEVICES]
- [71 FR 39172, July 11, 2006, as amended at 78 FR 6696, Jan. 30, 2013; 81 FR 44219, July 7, 2016]

V. REPORTING REQUIREMENTS.

No additional reporting requirements exist except as provided in other sections of this permit including Section B (Title V General Requirements).

VI. WORK PRACTICE REQUIREMENTS.

- # 006 [40 CFR Part 60 Standards of Performance for New Stationary Sources §40 CFR 60.4211]
Subpart III - Standards of Performance for Stationary Compression Ignition Internal Combustion Engines
What are my compliance requirements if I am an owner or operator of a stationary CI internal combustion engine?**
- (a) If you are an owner or operator and must comply with the emission standards specified in 40 CFR Part 60, Subpart III, you must do all of the following, except as permitted under 40 CFR §60.4211(g), below:
- (1) Operate and maintain the stationary CI internal combustion engines and control device according to the manufacturer's emission-related written instructions;
 - (2) Change only those emission-related settings that are permitted by the manufacturer; and
 - (3) Meet the requirements of 40 CFR Parts 89, 94 and/or 1068, as they apply to you.
- (b) If you are an owner or operator of a pre-2007 model year stationary CI internal combustion engine and must comply with the emission standards specified in 40 CFR §§ 60.4204(a) or 60.4205(a), or if you are an owner or operator of a CI fire pump engine that is manufactured prior to the model years in Table 3 to 40 CFR Part 60, Subpart III (i.e., pre-model year 2009), and must comply with the emission standards specified in 40 CFR §60.4205(c), you must demonstrate compliance according to one of the methods specified in 40 CFR §60.4211(b)(1) through (5), below. [NOTE: THE STATIONARY CI ICEs ARE PRE-MODEL YEAR 2009 CI FIRE PUMP ENGINES THAT MUST COMPLY WITH THE EMISSION STANDARDS SPECIFIED IN 40 CFR §60.4205(c)]
- (1) Purchasing an engine certified according to 40 CFR Part 89 or 40 CFR Part 94, as applicable, for the same model year

**SECTION E. Source Group Restrictions.**

and maximum engine power. The engine must be installed and configured according to the manufacturer's specifications.

(2) [N/A - THE STATIONARY CI ICEs ARE CERTIFIED ENGINES PURSUANT TO PARAGRAPH (b)(1), ABOVE]

(3) [N/A - THE STATIONARY CI ICEs ARE CERTIFIED ENGINES PURSUANT TO PARAGRAPH (b)(1), ABOVE]

(4) [N/A - THE STATIONARY CI ICEs ARE CERTIFIED ENGINES PURSUANT TO PARAGRAPH (b)(1), ABOVE]

(5) [N/A - THE STATIONARY CI ICEs ARE CERTIFIED ENGINES PURSUANT TO PARAGRAPH (b)(1), ABOVE]

(c) [N/A - THE STATIONARY CI ICEs ARE MODEL YEAR 2007 UNITS; SINCE THESE ARE FIRE PUMP ENGINES, TABLE 3 TO 40 CFR PART 60, SUBPART III, INDICATES THAT THIS PARAGRAPH (40 CFR §60.4211(c)) IS APPLICABLE TO MODEL YEAR 2009 AND LATER FIRE PUMP ENGINES]

(d) [N/A - THE STATIONARY CI ICEs DO NOT HAVE TO COMPLY WITH THE EMISSION STANDARDS SPECIFIED IN 40 CFR §60.4204(c) or 40 CFR §60.4205(d)]

(e) [N/A - THE STATIONARY CI ICEs ARE NOT MODIFIED OR RECONSTRUCTED CI ICEs]

(f) If you own or operate an emergency stationary ICE, you must operate the emergency stationary ICE according to the requirements in 40 CFR §60.4211(f)(1) through (3), below. In order for the engine to be considered an emergency stationary ICE under 40 CFR Part 60, Subpart III, any operation other than emergency operation, maintenance and testing, emergency demand response, and operation in non-emergency situations for 50 hours per year, as described in 40 CFR §60.4211(f)(1) through (3), below, is prohibited. If you do not operate the engine according to the requirements in 40 CFR §60.4211(f)(1) through (3), below, the engine will not be considered an emergency engine under 40 CFR Part 60, Subpart III, and must meet all requirements for non-emergency engines.

(1) There is no time limit on the use of emergency stationary ICE in emergency situations.

(2) You may operate your emergency stationary ICE for any combination of the purposes specified in 40 CFR §60.4211(f)(2)(i) through (iii), below, for a maximum of 100 hours per calendar year. Any operation for non-emergency situations as allowed by 40 CFR §60.4211(f)(3), below, counts as part of the 100 hours per calendar year allowed by this paragraph [40 CFR §60.4211(f)(2)].

(i) Emergency stationary ICE may be operated for maintenance checks and readiness testing, provided that the tests are recommended by federal, state or local government, the manufacturer, the vendor, the regional transmission organization or equivalent balancing authority and transmission operator, or the insurance company associated with the engine. The owner or operator may petition the Administrator for approval of additional hours to be used for maintenance checks and readiness testing, but a petition is not required if the owner or operator maintains records indicating that federal, state, or local standards require maintenance and testing of emergency ICE beyond 100 hours per calendar year.

(ii)-(iii) [N/A - VACATED AS OF MAY 2, 2016 PER COURT ORDER]

(3) Emergency stationary ICE may be operated for up to 50 hours per calendar year in non-emergency situations. The 50 hours of operation in non-emergency situations are counted as part of the 100 hours per calendar year for maintenance and testing and emergency demand response provided in 40 CFR §60.4211(f)(2), above. Except as provided in 40 CFR §60.4211(f)(3)(i), below, the 50 hours per calendar year for non-emergency situations cannot be used for peak shaving or non-emergency demand response, or to generate income for a facility to an electric grid or otherwise supply power as part of a financial arrangement with another entity.

(i) The 50 hours per year for non-emergency situations can be used to supply power as part of a financial arrangement with another entity if all of the following conditions are met:

(A) The engine is dispatched by the local balancing authority or local transmission and distribution system operator;

(B) The dispatch is intended to mitigate local transmission and/or distribution limitations so as to avert potential voltage collapse or line overloads that could lead to the interruption of power supply in a local area or region.

**SECTION E. Source Group Restrictions.**

(C) The dispatch follows reliability, emergency operation or similar protocols that follow specific NERC, regional, state, public utility commission or local standards or guidelines.

(D) The power is provided only to the facility itself or to support the local transmission and distribution system.

(E) The owner or operator identifies and records the entity that dispatches the engine and the specific NERC, regional, state, public utility commission or local standards or guidelines that are being followed for dispatching the engine. The local balancing authority or local transmission and distribution system operator may keep these records on behalf of the engine owner or operator.

(ii) [Reserved]

(g) If you do not install, configure, operate, and maintain your engine and control device according to the manufacturer's emission-related written instructions, or you change emission-related settings in a way that is not permitted by the manufacturer, you must demonstrate compliance as follows:

(1) [N/A - THE STATIONARY CI ICEs HAVE A MAXIMUM ENGINE POWER GREATER THAN OR EQUAL TO 100 HP]

(2) If you are an owner or operator of a stationary CI internal combustion engine greater than or equal to 100 HP and less than or equal to 500 HP, you must keep a maintenance plan and records of conducted maintenance and must, to the extent practicable, maintain and operate the engine in a manner consistent with good air pollution control practice for minimizing emissions. In addition, you must conduct an initial performance test to demonstrate compliance with the applicable emission standards within 1 year of startup, or within 1 year after an engine and control device is no longer installed, configured, operated, and maintained in accordance with the manufacturer's emission-related written instructions, or within 1 year after you change emission-related settings in a way that is not permitted by the manufacturer.

(3) [N/A - THE STATIONARY CI ICEs HAVE A MAXIMUM ENGINE POWER LESS THAN OR EQUAL TO 500 HP]

(h) [N/A - THE STATIONARY CI ICEs ARE NOT EQUIPPED WITH AUXILIARY EMISSION CONTROL DEVICES]

[71 FR 39172, July 11, 2006, as amended at 76 FR 37970, June 28, 2011; 78 FR 6695, Jan. 30, 2013; 81 FR 44219, July 7, 2016]

VII. ADDITIONAL REQUIREMENTS.**# 007 [25 Pa. Code §127.512]****Operating permit terms and conditions.**

In the event that 40 CFR Part 60, Subpart IIII - Standards of Performance for Stationary Compression Ignition Internal Combustion Engines (NSPS Subpart IIII) is revised, the permittee shall comply with the revised version of NSPS Subpart IIII, and shall not be required to comply with any provisions in this operating permit designated as having NSPS Subpart IIII as their authority, to the extent that such operating permit provisions would be inconsistent with the applicable provisions of the revised NSPS Subpart IIII.

008 [40 CFR Part 60 Standards of Performance for New Stationary Sources §40 CFR 60.4]**Subpart A - General Provisions****Address.**

The Group 010 engines are subject to 40 CFR Part 60, Subpart IIII - Standards of Performance for Stationary Compression Ignition Internal Combustion Engines. The permittee shall comply with all applicable standards, compliance provisions, performance test, monitoring, record keeping, and reporting requirements contained at 40 CFR §§60.4200 through 60.4219, including all applicable portions of 40 CFR Part 60, Subpart A - General Provisions. The permittee shall comply with 40 CFR §60.4, which requires submission of copies of all requests, reports, applications, submittals, and other communications to both the U.S. Environmental Protection Agency (U.S. EPA) and the Department. The U.S. EPA copies shall be forwarded to:

Director
Air Protection Division
U.S. EPA, Region III (3AP00)
1650 Arch Street

**SECTION E. Source Group Restrictions.**

Philadelphia, PA 19103-2029

The Department copies shall be forwarded to:

Regional Air Program Manager
PA Department of Environmental Protection
909 Elmerton Avenue
Harrisburg, PA 17110-8200

**# 009 [40 CFR Part 60 Standards of Performance for New Stationary Sources §40 CFR 60.4200]
Subpart III - Standards of Performance for Stationary Compression Ignition Internal Combustion Engines
Am I subject to this subpart?**

(a) The provisions of 40 CFR Part 60, Subpart III, are applicable to manufacturers, owners, and operators of stationary compression ignition (CI) internal combustion engines (ICEs) and other persons as specified in 40 CFR §60.4200(a)(1) through (4), below. For the purposes of 40 CFR Part 60, Subpart III, the date that construction commences is the date the engine is ordered by the owner or operator.

(1) [N/A - THE PERMITTEE IS NOT A MANUFACTURER OF STATIONARY CI ICEs]

(2) Owners and operators of stationary CI ICE that commence construction after July 11, 2005, where the stationary CI ICE are:

(i) [N/A - THE STATIONARY CI ICEs ARE FIRE PUMP ENGINES]

(ii) Manufactured as a certified National Fire Protection Association (NFPA) fire pump engine after July 1, 2006.

(3) [N/A - THE STATIONARY CI ICEs HAVE NOT BEEN NOT MODIFIED OR RECONSTRUCTED AFTER JULY 11, 2005]

(4) The provisions of 40 CFR §60.4208 are applicable to all owners and operators of stationary CI ICEs that commence construction after July 11, 2005.

(b) [N/A - THE STATIONARY CI ICEs ARE NOT BEING TESTED AT A STATIONARY CI ICE TEST CELL/STAND]

(c) [N/A - THE FACILITY IS A MAJOR SOURCE OF HAP EMISSIONS AND CURRENTLY POSSESSES A TITLE V OPERATING PERMIT]

(d) Stationary CI ICE may be eligible for exemption from the requirements of 40 CFR Part 60, Subpart III, as described in 40 CFR Part 1068, Subpart C (or the exemptions described in 40 CFR Part 89, Subpart J, and 40 CFR Part 94, Subpart J, for engines that would need to be certified to standards in those parts), except that owners and operators, as well as manufacturers, may be eligible to request an exemption for national security.

(e) [N/A - THE STATIONARY CI ICEs ARE NOT ACTING AS TEMPORARY REPLACEMENT UNITS]

[71 FR 39172, July 11, 2006, as amended at 76 FR 37967, June 28, 2011]

**# 010 [40 CFR Part 60 Standards of Performance for New Stationary Sources §40 CFR 60.4218]
Subpart III - Standards of Performance for Stationary Compression Ignition Internal Combustion Engines
What parts of the General Provisions apply to me?**

Table 8 to 40 CFR Part 60, Subpart III, shows which parts of the General Provisions in 40 CFR §§60.1 through 60.19 apply to you.

[71 FR 39172, July 11, 2006]

**# 011 [40 CFR Part 60 Standards of Performance for New Stationary Sources §40 CFR 60.4219]
Subpart III - Standards of Performance for Stationary Compression Ignition Internal Combustion Engines
What definitions apply to this subpart?**

Terms used in 40 CFR Part 60, Subpart III - Standards of Performance for Stationary Compression Ignition Internal Combustion Engines, as well as Section E, Group 010, are defined in the Clean Air Act; in 40 CFR §60.2 (General

**SECTION E. Source Group Restrictions.**

Provisions); and in 40 CFR §60.4219.

[71 FR 39172, July 11, 2006, as amended at 76 FR 37972, June 28, 2011; 78 FR 6696, Jan. 30, 2013; 81 FR 44219, July 7, 2016]

***** Permit Shield in Effect. *****

**SECTION E. Source Group Restrictions.**

Group Name: GROUP 011

Group Description: Sources Controlled by MDSI Systems

Sources included in this group

ID	Name
031A	BRUNNER ISLAND UNIT 1
032	BRUNNER ISLAND UNIT 2
033A	BRUNNER ISLAND UNIT 3

I. RESTRICTIONS.

No additional requirements exist except as provided in other sections of this permit including Section B (Title V General Requirements).

II. TESTING REQUIREMENTS.

No additional testing requirements exist except as provided in other sections of this permit including Section B (Title V General Requirements).

III. MONITORING REQUIREMENTS.

No additional monitoring requirements exist except as provided in other sections of this permit including Section B (Title V General Requirements).

IV. RECORDKEEPING REQUIREMENTS.**# 001 [25 Pa. Code §127.511]****Monitoring and related recordkeeping and reporting requirements.**

[Additional authority for this permit condition is also derived from Plan Approval No. 67-05005]

The permittee shall maintain a copy of the Safety Data Sheet (SDS) for each mercury dry sorbent used by the Group 011 mercury dry sorbent injection systems for the most recent five (5)-year period. The SDS copies shall be made available to the Department upon its request.

002 [25 Pa. Code §127.511]**Monitoring and related recordkeeping and reporting requirements.**

[Additional authority for this permit condition is also derived from Plan Approval No. 67-05005]

(a) The permittee shall maintain detailed records of all maintenance performed on any of the Group 011 mercury dry sorbent injection systems.

(b) The permittee shall retain these records for a minimum of five (5) years and shall make them available to the Department upon its request.

V. REPORTING REQUIREMENTS.**# 003 [25 Pa. Code §127.511]****Monitoring and related recordkeeping and reporting requirements.**

[Additional authority for this permit condition is also derived from Plan Approval No. 67-05005]

(a) The permittee shall report, in writing, any new mercury dry sorbent (including its MSDS) used by any of the Group 011 mercury dry sorbent injection (MDSI) systems to the Department at the following address prior to its use:

Regional Manager
PA Department of Environmental Protection
Southcentral Regional Office
Air Quality Program
909 Elmerton Avenue
Harrisburg, PA 17110-8200

(b) The Department shall approve, in writing, the use of any new mercury dry sorbent used by any of the Group 011 MDSI systems prior to its use.

**SECTION E. Source Group Restrictions.****VI. WORK PRACTICE REQUIREMENTS.****# 004 [25 Pa. Code §127.512]****Operating permit terms and conditions.**

[Additional authority for this permit condition is also derived from Plan Approval No. 67-05005]

Each Group 011 utility boiler and its associated mercury dry sorbent injection system shall be:

(a) Operated in such a manner as to not cause air pollution as that term is defined in the Air Pollution Control Act (35 P.S. §§4001 - 4015) and 25 Pa. Code §121.1;

(b) Operated and maintained in a manner consistent with good operating and maintenance practices; and

(c) Operated and maintained in accordance with the manufacturer's specifications.

005 [25 Pa. Code §127.512]**Operating permit terms and conditions.**

[Additional authority for this permit condition is also derived from Plan Approval No. 67-05005]

Operation of either of the Group 011 mercury dry sorbent injection systems by the permittee is optional except as may be required to comply with the applicable requirements of 40 CFR Part 63, Subpart UUUUU – National Emission Standards for Hazardous Air Pollutants: Coal- and Oil-Fired Electric Utility Steam Generating Units (MACT Subpart UUUUU). The applicable requirements of MACT Subpart UUUUU are found in Section E (Group 009) of this Title V Operating Permit (O.P. No. 67-05005).

VII. ADDITIONAL REQUIREMENTS.

No additional requirements exist except as provided in other sections of this permit including Section B (Title V General Requirements).

***** Permit Shield in Effect. *****

**SECTION E. Source Group Restrictions.**

Group Name: GROUP 012

Group Description: Utility Boilers Subject to RACT 2

Sources included in this group

ID	Name
031A	BRUNNER ISLAND UNIT 1
032	BRUNNER ISLAND UNIT 2
033A	BRUNNER ISLAND UNIT 3

I. RESTRICTIONS.

No additional requirements exist except as provided in other sections of this permit including Section B (Title V General Requirements).

II. TESTING REQUIREMENTS.

No additional testing requirements exist except as provided in other sections of this permit including Section B (Title V General Requirements).

III. MONITORING REQUIREMENTS.

No additional monitoring requirements exist except as provided in other sections of this permit including Section B (Title V General Requirements).

IV. RECORDKEEPING REQUIREMENTS.

No additional record keeping requirements exist except as provided in other sections of this permit including Section B (Title V General Requirements).

V. REPORTING REQUIREMENTS.

No additional reporting requirements exist except as provided in other sections of this permit including Section B (Title V General Requirements).

VI. WORK PRACTICE REQUIREMENTS.

No additional work practice requirements exist except as provided in other sections of this permit including Section B (Title V General Requirements).

VII. ADDITIONAL REQUIREMENTS.**# 001 [25 Pa. Code §127.512]****Operating permit terms and conditions.**

I.

Pursuant to 25 Pa. Code §129.98(a), the owner or operator of a major NO_x-emitting facility subject to 25 Pa. Code §129.96 that includes at least one air contamination source subject to a NO_x RACT emission limitation in 25 Pa. Code §129.97 that cannot meet the applicable NO_x RACT emission limitation may elect to meet the applicable NO_x RACT emission limitation in 25 Pa. Code §129.97 by averaging NO_x emissions on a facility-wide basis using a 30-day rolling average.

II.

Compliance with the alternative facility-wide NO_x RACT emissions limit of a facility-wide NO_x RACT emissions averaging plan shall be determined by comparing daily the sum of actual NO_x emissions from all the sources included in the averaging plan to the alternative facility-wide NO_x RACT emissions limit. The owner or operator shall calculate the alternative facility-wide NO_x RACT emissions limitation using a 30-day rolling average for the air contamination sources included in the facility-wide NO_x RACT emissions averaging plan by using the following equation to sum the emissions for all of the sources:

$$[\sum_{i=1}^n (E_{i\text{actual}})] \leq [\sum_{i=1}^n (E_{i\text{allowable}})] \quad \{\text{Equation 1}\}$$

**SECTION E. Source Group Restrictions.**

Where:

\sum = Symbol used to denote summation such that " $\sum_{i=1}^n A_i$ " means summation of values A_i for "i" ranging from 1 to the last value "n" where "n" is the number of non-zero values of " A_i ",

n = The number of air contamination sources included in the NOx emissions averaging plan,

$E_{iactual}$ = The actual NOx mass emissions, including emissions during startups, shutdowns and malfunctions, for air contamination source "i" on a 30-day rolling basis,

The symbol " \leq " means "less than or equal to",

$E_{iallowable}$ = The allowable NOx mass emissions computed using the allowable emission rate limitations for air contamination source "i" on a 30-day rolling basis specified in 25 Pa. Code §129.97. If an air contamination source included in an averaging plan is subject to a numerical emission rate limit that is more stringent than the applicable allowable emission rate limitation in 25 Pa. §129.97, then the numerical emission rate limit shall be used for the calculation of the allowable NOx mass emissions.

III.

The permittee shall utilize Department-certified CEMS to calculate actual emission when determining compliance with the facility-wide NOx RACT emissions averaging plan. The mass NOx emissions from each source within the averaging plan shall be calculated for each hour of operation and expressed in pounds per hour, which will be used in calculations to determine compliance on a 30-day rolling average.

IV.

The permittee shall utilize methods specified in 40 CFR Part 75, Appendix F, and 40 CFR Part 60, Appendix A, Method 19, when determining compliance with the facility-wide NOx RACT emissions averaging plan. The actual heat input from each source shall be calculated for each hour of operation and expressed in units of million British thermal units per hour (mmBTU/hr), which will be used in calculations to determine compliance on a 30-day rolling average basis.

V.

(a) The permittee shall keep records in accordance with the recordkeeping requirements of 25 Pa. Code §§129.95 and 129.100.

(b) The permittee shall keep records of all NOx emission data generated using the NOx CEMS required by this operating permit.

VI.

(a) The permittee shall keep records of the actual heat input, actual NOx mass emissions, and allowable NOx mass emissions for all sources addressed by the facility-wide NOx RACT emissions averaging plan. The records shall include all intermediate calculations.

(b) The permittee shall keep records necessary to demonstrate compliance with the facility-wide NOx RACT emissions averaging plan on a rolling 30-operating day basis. These records shall be made available at the facility (i.e., Brunner Island Steam Electric Station) to which the NOx RACT emissions averaging plan applies.

(c) The permittee shall retain these records for a minimum of five (5) years. The records shall be made available to the Department upon its request.

VII.

The boilers included in the facility-wide NOx RACT emissions averaging plan are these Group 012 boilers (Source IDs 031A, 032 and 033A).

**SECTION E. Source Group Restrictions.**

The permittee shall demonstrate compliance with the alternative facility-wide NO_x RACT emissions limitation of 25 Pa. Code §129.98(e) using Equation 1 of Part II., above, by keeping the following records pursuant to 25 Pa. Code §129.98(g)(3):

(a) Calculation of the Actual NO_x Mass Emissions (E_{actual})

(1) Calculate the daily actual NO_x mass emissions for each boiler* addressed in the facility-wide NO_x RACT emissions averaging plan for each day that at least one of the three boilers operates by summing the hourly NO_x mass emissions using the Department-certified NO_x CEMS. The daily actual NO_x mass emissions must include the emissions that occur during the entire operating day, including emissions from start-ups, shutdowns and malfunctions. Each day that at least one of the three boilers operates shall be defined as a "facility-wide operating day". The mass NO_x emissions from each source within the facility-wide NO_x RACT emissions averaging plan shall be calculated for each hour of operation and expressed in pounds per hour, which will be used in calculations to determine compliance on a 30-day rolling average basis.

(2) The 30-day rolling actual NO_x mass emissions for each boiler* addressed in the facility-wide NO_x RACT emissions averaging plan is calculated by summing the actual NO_x mass emissions for the current facility-wide operating day and the previous 29 facility-wide operating days.

(3) The 30-day rolling facility-wide actual NO_x mass emissions (E_{actual}) are calculated by summing the actual NO_x mass emissions of all three boilers addressed in the facility-wide NO_x RACT emissions averaging plan for the current facility-wide operating day and the previous 29 facility-wide operating days.

(4) The 30-day rolling facility-wide actual NO_x mass emissions (E_{actual}) shall be calculated for each consecutive facility-wide operating day in the facility-wide data acquisition handling system (DAHS).

(5) The permittee shall utilize 40 CFR Part 75 data substitution procedures for invalid data for hourly NO_x (lbs/hr) and heat input (mmBTU/hr).

* Source IDs 031A and 032 of Group 012 share a common stack and utilize a single NO_x CEMS, therefore their NO_x emissions are monitored and reported together. The other boiler (Source ID 033A of Group 012) has a unique stack and utilizes a dedicated NO_x CEMS.

(b) Calculation of the Allowable NO_x Emissions (E_{allowable})

(1) For the Brunner Island Steam Electric Station, the following equation (Equation 2) will be used to calculate Daily E_{allowable}:

$$\text{Daily } E_{\text{allowable}} = [\sum_{i=1}^n (W)(C) + (X)(NG) + (Y)(O)] / 2000 \quad \{\text{Equation 2}\}$$

Where:

Daily E_{allowable} = The allowable NO_x mass emissions computed using the allowable emission rate limitations for air contamination source "i" on a 30-day rolling basis specified in 25 Pa. Code 129.97. If an air contamination source included in an averaging plan is subject to a numerical emission rate limit that is more stringent than the applicable allowable emission rate limitation in 25 Pa. Code 129.97, then the numerical emission rate limit shall be used for the calculation of the allowable NO_x mass emissions.

∑ = Symbol used to denote summation such that "∑_{i=1}ⁿ A_i" means summation of values A_i for "i" ranging from 1 to the last value "n" where "n" is the number of non-zero values of "A_i",

n = The number of different NO_x CEMS located at Brunner Island Steam Electric Station = 2,

W = 0.35 lb NO_x/mmBTU,

C = The daily total heat input for coal, expressed in units of mmBTU,

**SECTION E. Source Group Restrictions.**

$X = 0.10 \text{ lb NOx/mmBTU}$,

NG = The daily total heat input for natural gas, expressed in units of mmBTU,

$Y = 0.12 \text{ lb NOx/mmBTU}$,

O = The daily total heat input for No. 2 fuel oil, expressed in units of mmBTU,

The symbol "/" means "divided by".

The daily heat inputs (C, NG, & O) shall be determined using fuel F-factors pursuant to the following: 40 CFR Part 75, Appendix F; 40 CFR Part 60, Appendix A, Method 19; and fuel flow meters for natural gas (NG) and No. 2 fuel oil (O). This data shall be maintained in the NOx CEMS DAHS.

 [NOTE: PURSUANT TO 25 Pa. Code §129.97(g)(4)(ii), A FUEL REPRESENTING LESS THAN 1% OF THE SOURCE'S ANNUAL FUEL CONSUMPTION ON A HEAT INPUT BASIS IS EXCLUDED WHEN DETERMINING THE APPLICABLE RACT MULTIPLE FUEL NOx EMISSION LIMIT CALCULATED IN ACCORDANCE WITH 25 Pa. Code §129.97(g)(4)(i); THEREFORE, SOME OF THE VARIABLES IDENTIFIED IN EQUATION 2, ABOVE, MIGHT BE ELIMINATED AS A RESULT DURING A GIVEN 30-DAY ROLLING PERIOD]

(2) The 30-day rolling facility-wide allowable NOx mass emissions (E_{allowable}) are calculated by summing the allowable NOx mass emissions for the Brunner Island Steam Electric Station for the current facility-wide operating day (Daily E_{allowable}) and the previous 29 facility-wide operating days.

(3) The 30-day rolling facility-wide allowable NOx mass emissions (E_{allowable}) shall be calculated for each consecutive facility-wide operating day in the facility-wide DAHS.

(c) Exclusion of Low Volume Fuel(s)

(1) Pursuant to 25 Pa. Code §129.97(g)(4)(ii), a fuel representing less than 1% of the source's annual fuel consumption on a heat input basis is excluded when determining the applicable RACT multiple fuel NOx emission limit calculation in accordance with 25 Pa. Code §129.97(g)(4)(i).

(2) For each source included in the facility-wide NOx emissions averaging plan that combusts any fuel(s) in an amount less than 1% of its annual (i.e., calendar year) fuel consumption on a heat input basis, the permittee shall keep records, pursuant to 25 Pa. Code §129.100(d), in order to maintain the exemption provided in part (c)(1), above, as well as 25 Pa. Code §129.97(g)(4)(ii).

(3) The permittee shall retain the records of part (c)(2), above, for a minimum of five (5) years. The records shall be made available to the Department upon its request.

(d) Actual Heat Input (mmBTU/hr) Calculation

The permittee shall utilize fuel flow monitors, or fuel F-factors as applicable, to calculate actual heat input when determining compliance with the NOx emissions averaging plan. The actual heat input from each source shall be calculated for each hour of operation and expressed in units of million British thermal units per hour (mmBTU/hr), which will be used in calculations to determine compliance on a 30-day rolling average basis.

(e) Comparison of E_{actual} to E_{allowable}

(1) Beginning on November 15, 2022, the permittee shall demonstrate compliance with the alternative facility-wide NOx RACT emissions limitation of Equation 1 of Part II. [25 Pa. Code §129.98(e)], above, using a 30-day rolling average by comparing E_{actual} to E_{allowable}.

(2) For each 30-day rolling period in which E_{actual} exceeds E_{allowable}, the permittee shall be liable for a violation of the



SECTION E. Source Group Restrictions.

applicable NOx RACT emission limitation at each of the three boilers included in the facility-wide NOx emissions averaging plan pursuant to 25 Pa. Code §129.98(m).

VIII

(a) The permittee shall submit quarterly RACT facility-wide NOx emissions averaging reports to Bill Weaver at wiweaver@pa.gov, unless otherwise specified by DEP.

(b) The permittee's demonstration of compliance with the facility-wide NOx emissions limit of Equation 1 of Part II. [25 Pa. Code §129.98(e)], above, shall be included in each quarterly RACT facility-wide NOx emissions averaging report.

(c) The quarterly RACT facility-wide NOx emissions averaging reports shall be submitted according to the following schedule:

- (1) The quarterly report for the period of January 1 - March 31 is due no later than April 30.
- (2) The quarterly report for the period of April 1 - June 30 is due no later than July 30.
- (3) The quarterly report for the period of July 1 - September 30 is due no later than October 30.
- (4) The quarterly report for the period of October 1 - December 31 is due no later than January 30.

(d) The permittee may request, in writing, an extension of time from the Department for the filing of a quarterly RACT facility-wide NOx emissions averaging report specified in part (a), above, and the Department may grant, in writing, the extension for reasonable cause.

IX.

Pursuant to 25 Pa. Code §129.97(d), the permittee shall maintain and operate each Group 012 boiler (Source IDs 031A, 032 and 033A) in accordance with the manufacturer's specifications and with good operating practices for the control of the VOC emissions from the combustion unit.

*** **Permit Shield in Effect.** ***

**SECTION E. Source Group Restrictions.**

Group Name: GROUP 013

Group Description: Sources Subject to MACT Subpart ZZZZ

Sources included in this group

ID	Name
401	UNIT 1 EMERGENCY ENGINE
402	UNIT 3 EMERGENCY ENGINE
403	EMERGENCY SUMP PUMP ENGINE
404	SERVICE WATER PUMP #3 ENGINE

I. RESTRICTIONS.

No additional requirements exist except as provided in other sections of this permit including Section B (Title V General Requirements).

II. TESTING REQUIREMENTS.

No additional testing requirements exist except as provided in other sections of this permit including Section B (Title V General Requirements).

III. MONITORING REQUIREMENTS.

No additional monitoring requirements exist except as provided in other sections of this permit including Section B (Title V General Requirements).

IV. RECORDKEEPING REQUIREMENTS.

No additional record keeping requirements exist except as provided in other sections of this permit including Section B (Title V General Requirements).

V. REPORTING REQUIREMENTS.

No additional reporting requirements exist except as provided in other sections of this permit including Section B (Title V General Requirements).

VI. WORK PRACTICE REQUIREMENTS.

No additional work practice requirements exist except as provided in other sections of this permit including Section B (Title V General Requirements).

VII. ADDITIONAL REQUIREMENTS.**# 001 [40 CFR Part 63 NESHAPS for Source Categories §40 CFR 63.6585]****Subpart ZZZZ - National Emissions Standards for Hazardous Air Pollutants for Stationary Reciprocating Internal Combustion Engines****Am I subject to this subpart?**

The Group 013 engines are subject to 40 CFR Part 63, Subpart ZZZZ - National Emissions Standards for Hazardous Air Pollutants for Stationary Reciprocating Internal Combustion Engines (MACT Subpart ZZZZ). The permittee shall comply with all applicable standards, compliance provisions, performance test, monitoring, recordkeeping, and reporting requirements of MACT Subpart ZZZZ, including all applicable portions of 40 CFR Part 63, Subpart A - General Provisions. The permittee shall comply with 40 CFR §63.13(a), which requires submission of copies of all requests, reports, applications, submittals, and other communications to both the U.S. Environmental Protection Agency (U.S. EPA) and the Department. The U.S. EPA copies shall be forwarded to:

Director
Air Protection Division
U.S. EPA, Region III (3AP00)
1650 Arch Street
Philadelphia, PA 19103-2029

The Department copies shall be forwarded to:

**SECTION E. Source Group Restrictions.**

Regional Air Program Manager
PA Department of Environmental Protection
909 Elmerton Avenue
Harrisburg, PA 17110-8200

In the event that MACT Subpart ZZZZ is revised by U.S. EPA, the permittee shall comply with the revised version of MACT Subpart ZZZZ, and shall not be required to comply with any provisions in this operating permit designated as having MACT Subpart ZZZZ as their authority, to the extent that such operating permit provisions would be inconsistent with the applicable provisions of the revised version of MACT Subpart ZZZZ.

002 [40 CFR Part 63 NESHAPS for Source Categories §40 CFR 63.6585]**Subpart ZZZZ - National Emissions Standards for Hazardous Air Pollutants for Stationary Reciprocating Internal Combustion Engines****Am I subject to this subpart?**

40 CFR §63.6585 Am I subject to this subpart?

You are subject to MACT Subpart ZZZZ if you own or operate a stationary RICE at a major or area source of HAP emissions, except if the stationary RICE is being tested at a stationary RICE test cell/stand.

(a) A stationary RICE is any internal combustion engine which uses reciprocating motion to convert heat energy into mechanical work and which is not mobile. Stationary RICE differ from mobile RICE in that a stationary RICE is not a non-road engine as defined at 40 CFR §1068.30, and is not used to propel a motor vehicle or a vehicle used solely for competition.

(b) A major source of HAP emissions is a plant site that emits or has the potential to emit any single HAP at a rate of 10 tons (9.07 megagrams) or more per year or any combination of HAP at a rate of 25 tons (22.68 megagrams) or more per year, except that for oil and gas production facilities, a major source of HAP emissions is determined for each surface site. [NOTE: THE FACILITY IS A MAJOR SOURCE OF HAP EMISSIONS PURSUANT TO 40 CFR §§63.2 AND 63.6585(b)]

(c) [N/A – THE FACILITY IS A MAJOR SOURCE OF HAP EMISSIONS PURSUANT TO 40 CFR §§63.2 AND 63.6585(b)]

(d) [N/A – THE FACILITY IS A MAJOR SOURCE OF HAP EMISSIONS PURSUANT TO 40 CFR §§63.2 AND 63.6585(b)]

(e) [N/A – THE NATIONAL SECURITY EXEMPTION DOES NOT APPLY]

(f) [N/A – THE FACILITY IS NOT A RESIDENTIAL/COMMERCIAL/INSTITUTIONAL ENTITY]

[69 FR 33506, June 15, 2004, as amended at 73 FR 3603, Jan. 18, 2008; 78 FR 6700, Jan. 30, 2013]

40 CFR §63.6590 What parts of my plant does this subpart cover?

MACT Subpart ZZZZ applies to each affected source.

(a) Affected source. An affected source is any existing, new, or reconstructed stationary RICE located at a major or area source of HAP emissions, excluding stationary RICE being tested at a stationary RICE test cell/stand.

(1) Existing stationary RICE.

(i) [N/A – EACH ENGINE HAS A SITE RATING OF <= 500 HP]

(ii) For stationary RICE with a site rating of less than or equal to 500 brake HP located at a major source of HAP emissions, a stationary RICE is existing if you commenced construction or reconstruction of the stationary RICE before June 12, 2006.

(iii) [N/A – THE FACILITY IS A MAJOR SOURCE OF HAP EMISSIONS PURSUANT TO 40 CFR §§63.2 AND 63.6585(b)]

**SECTION E. Source Group Restrictions.**

(iv) A change in ownership of an existing stationary RICE does not make that stationary RICE a new or reconstructed stationary RICE.

(2) [N/A – EACH ENGINE IS DEFINED AS "EXISTING" PURSUANT TO 40 CFR §63.6590(a)(1)(ii)]

(3) [N/A – EACH ENGINE IS DEFINED AS "EXISTING" PURSUANT TO 40 CFR §63.6590(a)(1)(ii)]

(b) Stationary RICE subject to limited requirements.

(1) [N/A – EACH ENGINE IS DEFINED AS "EXISTING" PURSUANT TO 40 CFR §63.6590(a)(1)(ii)]

(2) [N/A – EACH ENGINE IS DEFINED AS "EXISTING" PURSUANT TO 40 CFR §63.6590(a)(1)(ii)]

(3) The following stationary RICE do not have to meet the requirements of MACT Subpart ZZZZ and 40 CFR Part 63, Subpart A (General Provisions), including initial notification requirements:

(i) [N/A – EACH ENGINE HAS A SITE RATING OF \leq 500 HP]

(ii) [N/A – EACH ENGINE HAS A SITE RATING OF \leq 500 HP]

(iii) [N/A – EACH ENGINE HAS A SITE RATING OF \leq 500 HP]

(iv) [N/A – EACH ENGINE HAS A SITE RATING OF \leq 500 HP]

(v) [N/A – EACH ENGINE HAS A SITE RATING OF \leq 500 HP]

(c) [N/A – EACH ENGINE IS DEFINED AS "EXISTING" PURSUANT TO 40 CFR §63.6590(a)(1)(ii)]

[69 FR 33506, June 15, 2004, as amended at 73 FR 3604, Jan. 18, 2008; 75 FR 9674, Mar. 3, 2010; 75 FR 37733, June 30, 2010; 75 FR 51588, Aug. 20, 2010; 78 FR 6700, Jan. 30, 2013]

40 CFR §63.6595 When do I have to comply with this subpart?

(a) Affected sources.

(1) If you have an existing stationary RICE, excluding existing non-emergency CI stationary RICE, with a site rating of more than 500 brake HP located at a major source of HAP emissions, you must comply with the applicable emission limitations, operating limitations and other requirements no later than June 15, 2007. If you have an existing non-emergency CI stationary RICE with a site rating of more than 500 brake HP located at a major source of HAP emissions, an existing stationary CI RICE with a site rating of less than or equal to 500 brake HP located at a major source of HAP emissions, or an existing stationary CI RICE located at an area source of HAP emissions, you must comply with the applicable emission limitations, operating limitations, and other requirements no later than May 3, 2013. If you have an existing stationary SI RICE with a site rating of less than or equal to 500 brake HP located at a major source of HAP emissions, or an existing stationary SI RICE located at an area source of HAP emissions, you must comply with the applicable emission limitations, operating limitations, and other requirements no later than October 19, 2013. [NOTE: EACH ENGINE IS AN EXISTING STATIONARY CI RICE WITH A SITE RATING OF LESS THAN OR EQUAL TO 500 BRAKE HP LOCATED AT A MAJOR SOURCE OF HAP EMISSIONS; THEREFORE, THEY MUST COMPLY WITH THE APPLICABLE EMISSION LIMITATIONS, OPERATING LIMITATIONS, AND OTHER MACT SUBPART ZZZZ REQUIREMENTS NO LATER THAN MAY 3, 2013]

(2) [N/A – EACH ENGINE IS DEFINED AS "EXISTING" PURSUANT TO 40 CFR §63.6590(a)(1)(ii)]

(3) [N/A – EACH ENGINE IS DEFINED AS "EXISTING" PURSUANT TO 40 CFR §63.6590(a)(1)(ii)]

(4) [N/A – EACH ENGINE IS DEFINED AS "EXISTING" PURSUANT TO 40 CFR §63.6590(a)(1)(ii)]

(5) [N/A – EACH ENGINE IS DEFINED AS "EXISTING" PURSUANT TO 40 CFR §63.6590(a)(1)(ii)]



SECTION E. Source Group Restrictions.

(6) [N/A – EACH ENGINE IS DEFINED AS "EXISTING" PURSUANT TO 40 CFR §63.6590(a)(1)(ii)]

(7) [N/A – EACH ENGINE IS DEFINED AS "EXISTING" PURSUANT TO 40 CFR §63.6590(a)(1)(ii)]

(b) [N/A – THE FACILITY IS A MAJOR SOURCE OF HAP EMISSIONS PURSUANT TO 40 CFR §§63.2 AND 63.6585(b)]

(c) If you own or operate an affected source, you must meet the applicable notification requirements in 40 CFR §63.6645 and in 40 CFR Part 63, Subpart A (General Provisions).

[69 FR 33506, June 15, 2004, as amended at 73 FR 3604, Jan. 18, 2008; 75 FR 9675, Mar. 3, 2010; 75 FR 51589, Aug. 20, 2010; 78 FR 6701, Jan. 30, 2013]

Emission and Operating Limitations

40 CFR §63.6600 What emission limitations and operating limitations must I meet if I own or operate a stationary RICE with a site rating of more than 500 brake HP located at a major source of HAP emissions?

[N/A – EACH ENGINE HAS A SITE RATING OF <= 500 HP]

40 CFR §63.6601 What emission limitations must I meet if I own or operate a new or reconstructed 4SLB stationary RICE with a site rating of greater than or equal to 250 brake HP and less than or equal to 500 brake HP located at a major source of HAP emissions?

[N/A – EACH ENGINE IS DEFINED AS "EXISTING" PURSUANT TO 40 CFR §63.6590(a)(1)(ii); ALSO, EACH ENGINE IS NOT A 4SLB ENGINE]

40 CFR §63.6602 What emission limitations and other requirements must I meet if I own or operate an existing stationary RICE with a site rating of equal to or less than 500 brake HP located at a major source of HAP emissions?

If you own or operate an existing stationary RICE with a site rating of equal to or less than 500 brake HP located at a major source of HAP emissions, you must comply with the emission limitations and other requirements in Table 2c to MACT Subpart ZZZZ which apply to you. Compliance with the numerical emission limitations established in MACT Subpart ZZZZ is based on the results of testing the average of three 1-hour runs using the testing requirements and procedures in 40 CFR §63.6620 and Table 4 to MACT Subpart ZZZZ.

[78 FR 6701, Jan. 30, 2013]

TABLE 2c REQUIREMENTS: Subcategory 1

For each emergency stationary CI RICE*, you must meet the following requirement, except during periods of startup:

- a. Change oil and filter every 500 hours of operation or annually, whichever comes first.**
- b. Inspect air cleaner every 1,000 hours of operation or annually, whichever comes first, and replace as necessary;
- c. Inspect all hoses and belts every 500 hours of operation or annually, whichever comes first, and replace as necessary.***

During periods of startup you must minimize the engine's time spent at idle and minimize the engine's startup time at startup to a period needed for appropriate and safe loading of the engine, not to exceed 30 minutes, after which time the non-startup emission limitations apply.***

* If an emergency engine is operating during an emergency and it is not possible to shut down the engine in order to

**SECTION E. Source Group Restrictions.**

perform the work practice requirements on the schedule required in Table 2c of MACT Subpart ZZZZ, or if performing the work practice on the required schedule would otherwise pose an unacceptable risk under federal, state, or local law, the work practice can be delayed until the emergency is over or the unacceptable risk under federal, state, or local law has abated. The work practice should be performed as soon as practicable after the emergency has ended or the unacceptable risk under federal, state, or local law has abated. Sources must report any failure to perform the work practice on the schedule required and the federal, state or local law under which the risk was deemed unacceptable.

** Sources have the option to utilize an oil analysis program as described in 40 CFR §63.6625(i) or (j) in order to extend the specified oil change requirement in Table 2c of MACT Subpart ZZZZ.

*** Sources can petition the Administrator pursuant to the requirements of 40 CFR §63.6(g) for alternative work practices.

[78 FR 6708, Jan. 30, 2013, as amended at 78 FR 14457, Mar. 6, 2013]

END OF TABLE 2c REQUIREMENTS

40 CFR §63.6603 What emission limitations, operating limitations, and other requirements must I meet if I own or operate an existing stationary RICE located at an area source of HAP emissions?

[N/A – THE FACILITY IS A MAJOR SOURCE OF HAP EMISSIONS PURSUANT TO 40 CFR §§63.2 AND 63.6585(b)]

40 CFR §63.6604 What fuel requirements must I meet if I own or operate a stationary CI RICE?

(a) [N/A – EACH ENGINE IS DEFINED AS AN "EMERGENCY STATIONARY RICE" PURSUANT TO 40 CFR §63.6675]

(b) Beginning January 1, 2015, if you own or operate an existing emergency CI stationary RICE with a site rating of more than 100 brake HP and a displacement of less than 30 liters per cylinder that uses diesel fuel and operates or is contractually obligated to be available for more than 15 hours per calendar year for the purposes specified in 40 CFR §63.6640(f)(2)(ii) and (iii) or that operates for the purpose specified in 40 CFR §63.6640(f)(4)(ii), you must use diesel fuel that meets the requirements in 40 CFR §80.510(b) for nonroad diesel fuel, except that any existing diesel fuel purchased (or otherwise obtained) prior to January 1, 2015, may be used until depleted. [NOTE: 40 CFR §63.6640(f)(2)(ii)&(iii) WERE VACATED AS OF MAY 2, 2016 PER COURT ORDER]

(c) [N/A – EACH ENGINE IS DEFINED AS "EXISTING" PURSUANT TO 40 CFR §63.6590(a)(1)(ii)]

(d) [N/A – EACH ENGINE IS NOT LOCATED IN ANY OF THE SPECIFIED GEOGRAPHICAL AREAS]

[78 FR 6702, Jan. 30, 2013]

General Compliance Requirements

40 CFR §63.6605 What are my general requirements for complying with this subpart?

(a) You must be in compliance with the emission limitations, operating limitations, and other requirements in MACT Subpart ZZZZ that apply to you at all times.

(b) At all times you must operate and maintain any affected source, including associated air pollution control equipment and monitoring equipment, in a manner consistent with safety and good air pollution control practices for minimizing emissions. The general duty to minimize emissions does not require you to make any further efforts to reduce emissions if levels required by MACT Subpart ZZZZ have been achieved. Determination of whether such operation and maintenance procedures are being used will be based on information available to the Administrator which may include, but is not limited to, monitoring results, review of operation and maintenance procedures, review of operation and maintenance records, and inspection of the source.

**SECTION E. Source Group Restrictions.**

[75 FR 9675, Mar. 3, 2010, as amended at 78 FR 6702, Jan. 30, 2013]

Testing and Initial Compliance Requirements

40 CFR §63.6610 By what date must I conduct the initial performance tests or other initial compliance demonstrations if I own or operate a stationary RICE with a site rating of more than 500 brake HP located at a major source of HAP emissions?

[N/A – EACH ENGINE HAS A SITE RATING OF <= 500 HP]

40 CFR §63.6611 By what date must I conduct the initial performance tests or other initial compliance demonstrations if I own or operate a new or reconstructed 4SLB SI stationary RICE with a site rating of greater than or equal to 250 and less than or equal to 500 brake HP located at a major source of HAP emissions?

[N/A – EACH ENGINE IS DEFINED AS "EXISTING" PURSUANT TO 40 CFR §63.6590(a)(1)(ii); ALSO, EACH ENGINE IS NOT A 4SLB ENGINE]

40 CFR §63.6612 By what date must I conduct the initial performance tests or other initial compliance demonstrations if I own or operate an existing stationary RICE with a site rating of less than or equal to 500 brake HP located at a major source of HAP emissions or an existing stationary RICE located at an area source of HAP emissions?

If you own or operate an existing stationary RICE with a site rating of less than or equal to 500 brake HP located at a major source of HAP emissions or an existing stationary RICE located at an area source of HAP emissions you are subject to the requirements of this section (i.e., 40 CFR §63.6612).

(a) [N/A - PURSUANT TO TABLES 4 AND 5, NO PERFORMANCE TESTING APPLIES TO EMERGENCY ENGINES]

(b) [N/A - PURSUANT TO TABLES 4 AND 5, NO PERFORMANCE TESTING APPLIES TO EMERGENCY ENGINES]

[75 FR 9676, Mar. 3, 2010, as amended at 75 FR 51589, Aug. 20, 2010]

40 CFR §63.6615 When must I conduct subsequent performance tests?

[N/A - PURSUANT TO TABLE 3, NO PERFORMANCE TESTING APPLIES TO EMERGENCY ENGINES]

40 CFR §63.6620 What performance tests and other procedures must I use?

[N/A - PURSUANT TO TABLES 4 AND 5, NO PERFORMANCE TESTING APPLIES TO EMERGENCY ENGINES]

40 CFR §63.6625 What are my monitoring, installation, collection, operation, and maintenance requirements?

(a) [N/A – NO CEMS REQUIRED OR ELECTED]

(b) [N/A – NO CPMS REQUIRED OR ELECTED]

(c) [N/A – EACH ENGINE IS DEFINED AS "EXISTING" PURSUANT TO 40 CFR §63.6590(a)(1)(ii); ALSO, EACH ENGINE DOES NOT FIRE EITHER LANDFILL GAS OR DIGESTER GAS]

(d) [N/A – EACH ENGINE IS DEFINED AS "EXISTING" PURSUANT TO 40 CFR §63.6590(a)(1)(ii); ALSO, EACH ENGINE IS NOT A 4SLB ENGINE]

(e) If you own or operate any of the following stationary RICE, you must operate and maintain the stationary RICE and after-

**SECTION E. Source Group Restrictions.**

treatment control device (if any) according to the manufacturer's emission-related written instructions or develop your own maintenance plan which must provide to the extent practicable for the maintenance and operation of the engine in a manner consistent with good air pollution control practice for minimizing emissions:

- (1) An existing stationary RICE with a site rating of less than 100 HP located at a major source of HAP emissions;
 - (2) An existing emergency or black start stationary RICE with a site rating of less than or equal to 500 HP located at a major source of HAP emissions;
 - (3) [N/A – THE FACILITY IS A MAJOR SOURCE OF HAP EMISSIONS PURSUANT TO 40 CFR §§63.2 AND 63.6585(b)]
 - (4) [N/A – THE FACILITY IS A MAJOR SOURCE OF HAP EMISSIONS PURSUANT TO 40 CFR §§63.2 AND 63.6585(b)]
 - (5) [N/A – THE FACILITY IS A MAJOR SOURCE OF HAP EMISSIONS PURSUANT TO 40 CFR §§63.2 AND 63.6585(b)]
 - (6) [N/A – THE FACILITY IS A MAJOR SOURCE OF HAP EMISSIONS PURSUANT TO 40 CFR §§63.2 AND 63.6585(b)]
 - (7) [N/A – THE FACILITY IS A MAJOR SOURCE OF HAP EMISSIONS PURSUANT TO 40 CFR §§63.2 AND 63.6585(b)]
 - (8) [N/A – THE FACILITY IS A MAJOR SOURCE OF HAP EMISSIONS PURSUANT TO 40 CFR §§63.2 AND 63.6585(b)]
 - (9) [N/A – THE FACILITY IS A MAJOR SOURCE OF HAP EMISSIONS PURSUANT TO 40 CFR §§63.2 AND 63.6585(b)]
 - (10) [N/A – THE FACILITY IS A MAJOR SOURCE OF HAP EMISSIONS PURSUANT TO 40 CFR §§63.2 AND 63.6585(b)]
- (f) If you own or operate an existing emergency stationary RICE with a site rating of less than or equal to 500 brake HP located at a major source of HAP emissions or an existing emergency stationary RICE located at an area source of HAP emissions, you must install a non-resettable hour meter if one is not already installed.
- (g) [N/A – EACH ENGINE IS DEFINED AS AN "EMERGENCY STATIONARY RICE" PURSUANT TO 40 CFR §63.6675]
- (h) If you operate a new, reconstructed, or existing stationary engine, you must minimize the engine's time spent at idle during startup and minimize the engine's startup time to a period needed for appropriate and safe loading of the engine, not to exceed 30 minutes, after which time the emission standards applicable to all times other than startup in Tables 1a, 2a, 2c, and 2d to this subpart apply. [NOTE: TABLE 2c IS THE ONLY APPLICABLE LISTED TABLE]
- (i) If you own or operate a stationary CI engine that is subject to the work, operation or management practices in items 1 or 2 of Table 2c to MACT Subpart ZZZZ or in items 1 or 4 of Table 2d to MACT Subpart ZZZZ, you have the option of utilizing an oil analysis program in order to extend the specified oil change requirement in Tables 2c and 2d to MACT Subpart ZZZZ. The oil analysis must be performed at the same frequency specified for changing the oil in Table 2c or 2d to MACT Subpart ZZZZ. The analysis program must at a minimum analyze the following three parameters: Total Base Number, viscosity, and percent water content. The condemning limits for these parameters are as follows: Total Base Number is less than 30 percent of the Total Base Number of the oil when new; viscosity of the oil has changed by more than 20 percent from the viscosity of the oil when new; or percent water content (by volume) is greater than 0.5. If all of these condemning limits are not exceeded, the engine owner or operator is not required to change the oil. If any of the limits are exceeded, the engine owner or operator must change the oil within 2 business days of receiving the results of the analysis; if the engine is not in operation when the results of the analysis are received, the engine owner or operator must change the oil within 2 business days or before commencing operation, whichever is later. The owner or operator must keep records of the parameters that are analyzed as part of the program, the results of the analysis, and the oil changes for the engine. The analysis program must be part of the maintenance plan for the engine. [NOTE: TABLE 2c IS THE ONLY APPLICABLE LISTED TABLE]
- (j) [N/A - EACH ENGINE IS A CI ENGINE]

[69 FR 33506, June 15, 2004, as amended at 73 FR 3606, Jan. 18, 2008; 75 FR 9676, Mar. 3, 2010; 75 FR 51589, Aug. 20, 2010; 76 FR 12866, Mar. 9, 2011; 78 FR 6703, Jan. 30, 2013]

**SECTION E. Source Group Restrictions.**

40 CFR §63.6630 How do I demonstrate initial compliance with the emission limitations, operating limitations, and other requirements?

(a) [N/A - PURSUANT TO TABLE 5, NO PERFORMANCE TESTING APPLIES TO EMERGENCY ENGINES]

(b) [N/A - PURSUANT TO TABLE 5, NO PERFORMANCE TESTING APPLIES TO EMERGENCY ENGINES]

(c) [N/A - EACH ENGINE IS AN EXISTING STATIONARY EMERGENCY RICE; ALSO, EACH ENGINE IS AN EXISTING STATIONARY RICE THAT IS NOT SUBJECT TO ANY NUMERICAL EMISSION STANDARDS; THEREFORE, THE SUBMISSION OF A NOTIFICATION OF COMPLIANCE STATUS (NOCS) IS NOT REQUIRED PURSUANT TO 40 CFR §63.6645(a)(5)]

(d) [N/A – EACH ENGINE IS DEFINED AS AN "EMERGENCY STATIONARY RICE" PURSUANT TO 40 CFR §63.6675]

(e) [N/A – EACH ENGINE IS DEFINED AS AN "EMERGENCY STATIONARY RICE" PURSUANT TO 40 CFR §63.6675]

[69 FR 33506, June 15, 2004, as amended at 78 FR 6704, Jan. 30, 2013]

Continuous Compliance Requirements

40 CFR §63.6635 How do I monitor and collect data to demonstrate continuous compliance?

[N/A – EACH ENGINE HAS NO EMISSION NOR OPERATING LIMITATIONS]

40 CFR §63.6640 How do I demonstrate continuous compliance with the emission limitations, operating limitations, and other requirements?

(a) You must demonstrate continuous compliance with each emission limitation, operating limitation, and other requirements in Tables 1a and 1b, Tables 2a and 2b, Table 2c, and Table 2d to MACT Subpart ZZZZ that apply to you according to methods specified in Table 6 to MACT Subpart ZZZZ. [NOTE: TABLE 2c IS THE ONLY APPLICABLE LISTED TABLE]

TABLE 6 REQUIREMENTS: Item 9

For each existing emergency and black start stationary RICE \leq 500 HP located at a major source of HAP, complying with the requirement to "Work or Management practices", you must demonstrate continuous compliance by:

i. Operating and maintaining the stationary RICE according to the manufacturer's emission-related operation and maintenance instructions; or

ii. Develop and follow your own maintenance plan which must provide to the extent practicable for the maintenance and operation of the engine in a manner consistent with good air pollution control practice for minimizing emissions.

[78 FR 6715, Jan. 30, 2013]

END OF TABLE 6 REQUIREMENTS

(b) [N/A – EACH ENGINE HAS NO EMISSION NOR OPERATING LIMITATIONS]

(c) [N/A – THE FACILITY IS A MAJOR SOURCE OF HAP EMISSIONS PURSUANT TO 40 CFR §§63.2 AND 63.6585(b); ALSO, EACH ENGINE IS NOT A 4SLB OR 4SRB ENGINE]

**SECTION E. Source Group Restrictions.**

(d) [N/A – EACH ENGINE IS DEFINED AS "EXISTING" PURSUANT TO 40 CFR §63.6590(a)(1)(ii)]

(e) You must also report each instance in which you did not meet the requirements in Table 8 to MACT Subpart ZZZZ that apply to you. If you own or operate a new or reconstructed stationary RICE with a site rating of less than or equal to 500 brake HP located at a major source of HAP emissions (except new or reconstructed 4SLB engines greater than or equal to 250 and less than or equal to 500 brake HP), a new or reconstructed stationary RICE located at an area source of HAP emissions, or any of the following RICE with a site rating of more than 500 brake HP located at a major source of HAP emissions, you do not need to comply with the requirements in Table 8 to MACT Subpart ZZZZ: An existing 2SLB stationary RICE, an existing 4SLB stationary RICE, an existing emergency stationary RICE, an existing limited use stationary RICE, or an existing stationary RICE which fires landfill gas or digester gas equivalent to 10 percent or more of the gross heat input on an annual basis. If you own or operate any of the following RICE with a site rating of more than 500 brake HP located at a major source of HAP emissions, you do not need to comply with the requirements in Table 8 to MACT Subpart ZZZZ, except for the initial notification requirements: a new or reconstructed stationary RICE that combusts landfill gas or digester gas equivalent to 10 percent or more of the gross heat input on an annual basis, a new or reconstructed emergency stationary RICE, or a new or reconstructed limited use stationary RICE. [NOTE: EXISTING EMERGENCY ENGINES AT A MAJOR SOURCE OF HAP EMISSIONS ARE NOT AMONG THOSE ENGINES EXEMPTED FROM COMPLYING WITH THE REQUIREMENTS IN TABLE 8 TO MACT SUBPART ZZZZ]

(f) If you own or operate an emergency stationary RICE, you must operate the emergency stationary RICE according to the requirements in 40 CFR Part 63, §63.6640(f)(1) through (4), below. In order for the engine to be considered an emergency stationary RICE under MACT Subpart ZZZZ, any operation other than emergency operation, maintenance and testing, emergency demand response, and operation in non-emergency situations for 50 hours per year, as described in 40 CFR §63.6640(f)(1) through (4), below, is prohibited. If you do not operate the engine according to the requirements in 40 CFR Part 63, §63.6640(f)(1) through (4), below, the engine will not be considered an emergency engine under MACT Subpart ZZZZ and must meet all requirements for non-emergency engines.

(1) There is no time limit on the use of emergency stationary RICE in emergency situations.

(2) You may operate your emergency stationary RICE for any combination of the purposes specified in 40 CFR Part 63, §63.6640(f)(2)(i) through (iii), below, for a maximum of 100 hours per calendar year. Any operation for non-emergency situations as allowed by 40 CFR §63.6640(f)(3) and (4), below, counts as part of the 100 hours per calendar year allowed by this paragraph [i.e., 40 CFR Part 63, §63.6640(f)(2)].

(i) Emergency stationary RICE may be operated for maintenance checks and readiness testing, provided that the tests are recommended by federal, state or local government, the manufacturer, the vendor, the regional transmission organization or equivalent balancing authority and transmission operator, or the insurance company associated with the engine. The owner or operator may petition the Administrator for approval of additional hours to be used for maintenance checks and readiness testing, but a petition is not required if the owner or operator maintains records indicating that federal, state, or local standards require maintenance and testing of emergency RICE beyond 100 hours per calendar year.

(ii)-(iii) [N/A - VACATED AS OF MAY 2, 2016 PER COURT ORDER]

(3) Emergency stationary RICE located at major sources of HAP may be operated for up to 50 hours per calendar year in non-emergency situations. The 50 hours of operation in non-emergency situations are counted as part of the 100 hours per calendar year for maintenance and testing and emergency demand response provided in 40 CFR Part 63, §63.6640(f)(2), above. The 50 hours per year for non-emergency situations cannot be used for peak shaving or non-emergency demand response, or to generate income for a facility to supply power to an electric grid or otherwise supply power as part of a financial arrangement with another entity.

(4) [N/A – THE FACILITY IS A MAJOR SOURCE OF HAP EMISSIONS PURSUANT TO 40 CFR §§63.2 AND 63.6585(b)]

[69 FR 33506, June 15, 2004, as amended at 71 FR 20467, Apr. 20, 2006; 73 FR 3606, Jan. 18, 2008; 75 FR 9676, Mar. 3, 2010; 75 FR 51591, Aug. 20, 2010; 78 FR 6704, Jan. 30, 2013]

Notifications, Reports, and Records

**SECTION E. Source Group Restrictions.**

40 CFR §63.6645 What notifications must I submit and when?

(a) You must submit all of the notifications in 40 CFR §§63.7(b) and (c), 63.8(e), (f)(4) and (f)(6), 63.9(b) through (e), and (g) and (h) that apply to you by the dates specified if you own or operate any of the following;

(1) An existing stationary RICE with a site rating of less than or equal to 500 brake HP located at a major source of HAP emissions. [NOTE: SEE 40 CFR §63.6645(a)(5), BELOW]

(2) [N/A – THE FACILITY IS A MAJOR SOURCE OF HAP EMISSIONS PURSUANT TO 40 CFR §§63.2 AND 63.6585(b)]

(3) [N/A – EACH ENGINE HAS A SITE RATING OF <= 500 HP]

(4) [N/A – EACH ENGINE IS DEFINED AS "EXISTING" PURSUANT TO 40 CFR §63.6590(a)(1)(ii)]

(5) This requirement does not apply if you own or operate an existing stationary RICE less than 100 HP, an existing stationary emergency RICE, or an existing stationary RICE that is not subject to any numerical emission standards. [NOTE: EACH ENGINE IS AN EXISTING STATIONARY EMERGENCY RICE; ALSO, EACH ENGINE IS AN EXISTING STATIONARY RICE THAT IS NOT SUBJECT TO ANY NUMERICAL EMISSION STANDARDS]

(b) [N/A – PURSUANT TO 40 CFR §63.6645(a)(5), ABOVE]

(c) [N/A – PURSUANT TO 40 CFR §63.6645(a)(5), ABOVE]

(d) [N/A – PURSUANT TO 40 CFR §63.6645(a)(5), ABOVE]

(e) [N/A – PURSUANT TO 40 CFR §63.6645(a)(5), ABOVE]

(f) [N/A – PURSUANT TO 40 CFR §§63.6590(b) AND 63.6645(a)(5), ABOVE]

(g) [N/A - PURSUANT TO TABLES 3, 4 AND 5, NO PERFORMANCE TESTING APPLIES TO EMERGENCY ENGINES]

(h) [N/A - PURSUANT TO TABLES 3, 4 AND 5, NO PERFORMANCE TESTING APPLIES TO EMERGENCY ENGINES]

(i) [N/A – THE FACILITY IS A MAJOR SOURCE OF HAP EMISSIONS PURSUANT TO 40 CFR §§63.2 AND 63.6585(b); ALSO, EACH ENGINE IS DEFINED AS AN "EMERGENCY STATIONARY RICE" PURSUANT TO 40 CFR §63.6675]

[73 FR 3606, Jan. 18, 2008, as amended at 75 FR 9677, Mar. 3, 2010; 75 FR 51591, Aug. 20, 2010; 78 FR 6705, Jan. 30, 2013]

40 CFR §63.6650 What reports must I submit and when?

(a) You must submit each report in Table 7 of MACT Subpart ZZZZ that applies to you.

TABLE 7 REQUIREMENTS:

Item 4: [N/A - 40 CFR §63.6640(f)(2)(ii)&(iii) WERE VACATED AS OF MAY 2, 2016 PER COURT ORDER]

[78 FR 6719, Jan. 30, 2013]

END OF TABLE 7 REQUIREMENTS

(b) [N/A – THERE ARE NO TABLE 7 REPORT SUBMISSIONS REQUIRED]

**SECTION E. Source Group Restrictions.**

(c) [N/A – THERE ARE NO TABLE 7 REPORT SUBMISSIONS REQUIRED]

(d) [N/A – THERE ARE NO TABLE 7 REPORT SUBMISSIONS REQUIRED]

(e) [N/A – THERE ARE NO TABLE 7 REPORT SUBMISSIONS REQUIRED]

(f) Each affected source that has obtained a Title V operating permit pursuant to 40 CFR Part 70 or 71 must report all deviations as defined in MACT Subpart ZZZZ in the semiannual monitoring report required by 40 CFR §70.6(a)(3)(iii)(A) or 40 CFR §71.6(a)(3)(iii)(A). If an affected source submits a Compliance report pursuant to Table 7 of MACT Subpart ZZZZ along with, or as part of, the semiannual monitoring report required by 40 CFR §70.6(a)(3)(iii)(A) or 40 CFR §71.6(a)(3)(iii)(A), and the Compliance report includes all required information concerning deviations from any emission or operating limitation in MACT Subpart ZZZZ, submission of the Compliance report shall be deemed to satisfy any obligation to report the same deviations in the semiannual monitoring report. However, submission of a Compliance report shall not otherwise affect any obligation the affected source may have to report deviations from permit requirements to the permit authority. [NOTE: THE SEMIANNUAL MONITORING REPORT REQUIRED BY "40 CFR §70.6(a)(3)(iii)(A) or 40 CFR §71.6(a)(3)(iii)(A)" REFERS TO THE SEMIANNUAL DEVIATIONS MONITORING REPORTING REQUIREMENT OF SECTION B, CONDITION #025(b), OF TITLE V O.P. No. 67-05005; A MACT SUBPART ZZZZ "COMPLIANCE REPORT" IS NOT REQUIRED TO BE SUBMITTED PURSUANT TO TABLE 7 OF MACT SUBPART ZZZZ]

(g) [N/A – EACH ENGINE IS DEFINED AS "EXISTING" PURSUANT TO 40 CFR §63.6590(a)(1)(ii); ALSO, LFG IS NOT COMBUSTED]

(h) [N/A - 40 CFR §63.6640(f)(2)(ii)&(iii) WERE VACATED AS OF MAY 2, 2016 PER COURT ORDER]

[69 FR 33506, June 15, 2004, as amended at 75 FR 9677, Mar. 3, 2010; 78 FR 6705, Jan. 30, 2013]

40 CFR §63.6655 What records must I keep?

(a) If you must comply with the emission and operating limitations, you must keep the records described in 40 CFR §63.6655(a)(1) through (a)(5), (b)(1) through (b)(3) and (c), below.

(1) A copy of each notification and report that you submitted to comply with MACT Subpart ZZZZ, including all documentation supporting any Initial Notification or Notification of Compliance Status that you submitted, according to the requirement in 40 CFR §63.10(b)(2)(xiv).

(2) Records of the occurrence and duration of each malfunction of operation (i.e., process equipment) or the air pollution control and monitoring equipment.

(3) [N/A - PURSUANT TO TABLES 3, 4 AND 5, NO PERFORMANCE TESTING APPLIES TO EMERGENCY ENGINES]

(4) [N/A – EACH ENGINE HAS NO EMISSION NOR OPERATING LIMITATIONS]

(5) Records of actions taken during periods of malfunction to minimize emissions in accordance with 40 CFR §63.6605(b), including corrective actions to restore malfunctioning process and air pollution control and monitoring equipment to its normal or usual manner of operation.

(b) [N/A – EACH ENGINE HAS NO EMISSION NOR OPERATING LIMITATIONS]

(c) [N/A – EACH ENGINE IS DEFINED AS "EXISTING" PURSUANT TO 40 CFR §63.6590(a)(1)(ii)]

(d) You must keep the records required in Table 6 of MACT Subpart ZZZZ to show continuous compliance with each emission or operating limitation that applies to you.

(e) You must keep records of the maintenance conducted on the stationary RICE in order to demonstrate that you operated and maintained the stationary RICE and after-treatment control device (if any) according to your own maintenance plan if you own or operate any of the following stationary RICE;

**SECTION E. Source Group Restrictions.**

(1) An existing stationary RICE with a site rating of less than 100 brake HP located at a major source of HAP emissions.

(2) An existing stationary emergency RICE.

(3) [N/A – THE FACILITY IS A MAJOR SOURCE OF HAP EMISSIONS PURSUANT TO 40 CFR §§63.2 AND 63.6585(b)]

(f) If you own or operate any of the stationary RICE in 40 CFR §63.6655(f)(1) through (2), below, you must keep records of the hours of operation of the engine that is recorded through the non-resettable hour meter. The owner or operator must document how many hours are spent for emergency operation, including what classified the operation as emergency and how many hours are spent for non-emergency operation. If the engine is used for the purposes specified in 40 CFR §63.6640(f)(2)(ii) or (iii) or 40 CFR §63.6640(f)(4)(ii), the owner or operator must keep records of the notification of the emergency situation, and the date, start time, and end time of engine operation for these purposes.

(1) An existing emergency stationary RICE with a site rating of less than or equal to 500 brake HP located at a major source of HAP emissions that does not meet the standards applicable to non-emergency engines.

(2) [N/A – THE FACILITY IS A MAJOR SOURCE OF HAP EMISSIONS PURSUANT TO 40 CFR §§63.2 AND 63.6585(b)]

[69 FR 33506, June 15, 2004, as amended at 75 FR 9678, Mar. 3, 2010; 75 FR 51592, Aug. 20, 2010; 78 FR 6706, Jan. 30, 2013]

40 CFR §63.6660 In what form and how long must I keep my records?

(a) Your records must be in a form suitable and readily available for expeditious review according to 40 CFR §63.10(b)(1).

(b) As specified in 40 CFR §63.10(b)(1), you must keep each record for 5 years following the date of each occurrence, measurement, maintenance, corrective action, report, or record.

(c) You must keep each record readily accessible in hard copy or electronic form for at least 5 years after the date of each occurrence, measurement, maintenance, corrective action, report, or record, according to 40 CFR §63.10(b)(1).

[69 FR 33506, June 15, 2004, as amended at 75 FR 9678, Mar. 3, 2010]

Other Requirements and Information

40 CFR §63.6665 What parts of the General Provisions apply to me?

Table 8 to MACT Subpart ZZZZ shows which parts of the General Provisions in 40 CFR §§63.1 through 63.15 apply to you. If you own or operate a new or reconstructed stationary RICE with a site rating of less than or equal to 500 brake HP located at a major source of HAP emissions (except new or reconstructed 4SLB engines greater than or equal to 250 and less than or equal to 500 brake HP), a new or reconstructed stationary RICE located at an area source of HAP emissions, or any of the following RICE with a site rating of more than 500 brake HP located at a major source of HAP emissions, you do not need to comply with any of the requirements of the General Provisions specified in Table 8 to MACT Subpart ZZZZ: An existing 2SLB stationary RICE, an existing 4SLB stationary RICE, an existing stationary RICE that combusts landfill or digester gas equivalent to 10 percent or more of the gross heat input on an annual basis, an existing emergency stationary RICE, or an existing limited use stationary RICE. If you own or operate any of the following RICE with a site rating of more than 500 brake HP located at a major source of HAP emissions, you do not need to comply with the requirements in the General Provisions specified in Table 8 to MACT Subpart ZZZZ except for the initial notification requirements: A new stationary RICE that combusts landfill gas or digester gas equivalent to 10 percent or more of the gross heat input on an annual basis, a new emergency stationary RICE, or a new limited use stationary RICE. [NOTE: AN EXISTING EMERGENCY RICE WITH A SITE RATING OF \leq 500 HP AT MAJOR HAP SOURCES IS NOT AMONG THOSE EXEMPTED FROM THIS SECTION (40 CFR §63.6665)]

[75 FR 9678, Mar. 3, 2010]

*** Permit Shield in Effect. ***

**SECTION E. Source Group Restrictions.**

Group Name: GROUP 014

Group Description: Sources Addressed by P.A. No. 67-05005H

Sources included in this group

ID	Name
031A	BRUNNER ISLAND UNIT 1
032	BRUNNER ISLAND UNIT 2
033A	BRUNNER ISLAND UNIT 3
050	FOUR NG-FIRED NG PIPELINE HEATERS
301	NATURAL GAS PIPELINE (PROCESS)

I. RESTRICTIONS.**Emission Restriction(s).****# 001 [25 Pa. Code §127.512]****Operating permit terms and conditions.**

[Additional authority for this permit condition is also derived from Plan Approval No. 67-05005H]

(a) The permittee shall comply with a VOC emission cap of 64.71 tons during any consecutive 12-month period for the Group 014 sources. The VOC emission cap for the Group 014 sources is a compliance cap, imposed for Prevention of Significant Deterioration (PSD) applicability purposes. This VOC emission cap shall not provide any relief from PSD applicability determinations for any future physical change or change in the method of operation of the Group 014 sources at the facility. The Group 014 sources covered under the aforementioned VOC emission cap shall be considered as one emissions unit, as defined in 25 Pa. Code §121.1 (relating to definitions), for PSD applicability purposes. Any future PSD applicability determinations must consider the baseline actual VOC emissions of all of the Group 014 sources as one emissions unit and not the VOC emission cap. In the event that PSD applicability is triggered for any of the Group 014 sources covered by the VOC emission cap, BACT shall apply to all of the Group 014 sources. If the permittee finds it necessary to relax the VOC emission cap at some future date, the source obligation requirements of 40 CFR §52.21(r)(4) shall apply.

(b) The provisions of part (a), above, do not preclude the permittee from seeking and procuring a plant-wide applicability limit (PAL) pursuant to 40 CFR §52.21(aa).

II. TESTING REQUIREMENTS.

No additional testing requirements exist except as provided in other sections of this permit including Section B (Title V General Requirements).

III. MONITORING REQUIREMENTS.

No additional monitoring requirements exist except as provided in other sections of this permit including Section B (Title V General Requirements).

IV. RECORDKEEPING REQUIREMENTS.**# 002 [25 Pa. Code §127.511]****Monitoring and related recordkeeping and reporting requirements.**

[Additional authority for this permit condition is also derived from Plan Approval No. 67-05005H]

(a) The permittee shall calculate the monthly VOC emissions from the Group 014 sources using AP-42 emission factors, manufacturer-supplied emission factors, mass material balance, performance (stack) test data, CEMS data, or other method(s) acceptable to the Department. The permittee shall maintain records of the monthly VOC emissions.

(b) The permittee shall calculate the cumulative VOC emissions from the Group 014 sources for each consecutive 12-month period. The permittee shall maintain records of the cumulative VOC emissions from the Group 014 sources for each consecutive 12-month period in order to demonstrate compliance with Condition #001, above.

(c) The permittee shall retain these records for a minimum of five (5) years. The records shall be made available to the



SECTION E. Source Group Restrictions.

Department upon its request.

V. REPORTING REQUIREMENTS.

003 [25 Pa. Code §127.511]
Monitoring and related recordkeeping and reporting requirements.
 [Additional authority for this permit condition is also derived from Plan Approval No. 67-05005H]

(a) An annual Group 014 VOC emissions report for a given calendar year is due within 60 days after the end of each calendar year, and shall be submitted to the Air Quality District Supervisor, at the following address, unless otherwise specified:

PA DEP
 Southcentral Regional Office
 Air Quality Program
 909 Elmerton Avenue
 Harrisburg, PA 17110-8200

(b) The monthly VOC emissions from the Group 014 sources including the calculation methodology referenced in Condition #002(a), above, shall be included in the annual VOC emissions report.

(c) The cumulative VOC emissions from the Group 014 sources for each consecutive 12-month period referenced in Condition #002(b), above, shall be included in the annual VOC emissions report.

VI. WORK PRACTICE REQUIREMENTS.

No additional work practice requirements exist except as provided in other sections of this permit including Section B (Title V General Requirements).

VII. ADDITIONAL REQUIREMENTS.

No additional requirements exist except as provided in other sections of this permit including Section B (Title V General Requirements).

***** Permit Shield in Effect. *****

**SECTION E. Source Group Restrictions.**

Group Name: GROUP 015

Group Description: Emergency Engines

Sources included in this group

ID	Name
401	UNIT 1 EMERGENCY ENGINE
402	UNIT 3 EMERGENCY ENGINE
403	EMERGENCY SUMP PUMP ENGINE
404	SERVICE WATER PUMP #3 ENGINE

I. RESTRICTIONS.**Emission Restriction(s).****# 001 [25 Pa. Code §123.13]****Processes**

Pursuant to 25 Pa. Code §123.13(c)(1)(i), the permittee shall not allow the emission into the outdoor atmosphere of filterable particulate matter (FPM) from each Group 015 engine in a manner that the concentration of PM in the effluent gas exceeds 0.04 grain per dry standard cubic foot.

002 [25 Pa. Code §123.21]**General**

The permittee shall not allow the emission into the outdoor atmosphere of sulfur oxides from each Group 015 engine in a manner that the concentration of the sulfur oxides (expressed as SO₂) in the effluent gas exceeds 500 parts per million, by volume, dry basis.

Fuel Restriction(s).**# 003 [25 Pa. Code §127.512]****Operating permit terms and conditions.**

The permittee shall operate each Group 015 engine using diesel/No. 2 fuel oil only.

II. TESTING REQUIREMENTS.

No additional testing requirements exist except as provided in other sections of this permit including Section B (Title V General Requirements).

III. MONITORING REQUIREMENTS.

No additional monitoring requirements exist except as provided in other sections of this permit including Section B (Title V General Requirements).

IV. RECORDKEEPING REQUIREMENTS.**# 004 [25 Pa. Code §129.100]****Compliance demonstration and recordkeeping requirements.**

(a) Pursuant to 25 Pa. Code §129.100(d), the permittee shall maintain a copy of each Group 015 engine manufacturer's specifications.

(b) Pursuant to 25 Pa. Code §129.100(d), the permittee shall maintain records of all maintenance activities to verify that each Group 015 engine has been maintained in accordance with the manufacturer's specifications.

(c) Pursuant to 25 Pa. Code §129.100(i), the permittee shall retain the records described in parts (a) and (b), above, for a minimum of five (5) years. The records shall be made available to the Department upon its request.

V. REPORTING REQUIREMENTS.

No additional reporting requirements exist except as provided in other sections of this permit including Section B (Title V General Requirements).

**SECTION E. Source Group Restrictions.****VI. WORK PRACTICE REQUIREMENTS.****# 005 [25 Pa. Code §129.97]****Presumptive RACT requirements, RACT emission limitations and petition for alternative compliance schedule.**

Pursuant to 25 Pa. Code §129.97(c)(5), the permittee shall operate and maintain each Group 015 engine in accordance with the manufacturer's specifications and with good operating practices for the control of NOx & VOC emissions.

[Compliance with this streamlined operating permit condition assures compliance with the presumptive RACT emission limit specified in 25 Pa. Code §129.93(c)(3)]

VII. ADDITIONAL REQUIREMENTS.

No additional requirements exist except as provided in other sections of this permit including Section B (Title V General Requirements).

***** Permit Shield in Effect. *****

**SECTION E. Source Group Restrictions.**

Group Name: GROUP 016

Group Description: Source Subject to MACT Subpart DDDDD

Sources included in this group

ID	Name
050	FOUR NG-FIRED NG PIPELINE HEATERS

I. RESTRICTIONS.

No additional requirements exist except as provided in other sections of this permit including Section B (Title V General Requirements).

II. TESTING REQUIREMENTS.

No additional testing requirements exist except as provided in other sections of this permit including Section B (Title V General Requirements).

III. MONITORING REQUIREMENTS.

No additional monitoring requirements exist except as provided in other sections of this permit including Section B (Title V General Requirements).

IV. RECORDKEEPING REQUIREMENTS.

No additional record keeping requirements exist except as provided in other sections of this permit including Section B (Title V General Requirements).

V. REPORTING REQUIREMENTS.

No additional reporting requirements exist except as provided in other sections of this permit including Section B (Title V General Requirements).

VI. WORK PRACTICE REQUIREMENTS.

No additional work practice requirements exist except as provided in other sections of this permit including Section B (Title V General Requirements).

VII. ADDITIONAL REQUIREMENTS.**# 001 [25 Pa. Code §127.512]****Operating permit terms and conditions.**

[Additional authority for this permit condition is also derived from Plan Approval No. 67-05005H]

In the event that 40 CFR Part 63, Subpart DDDDD - National Emission Standards for Hazardous Air Pollutants for Major Sources: Industrial, Commercial, and Institutional Boilers and Process Heaters (MACT Subpart DDDDD) is revised, the permittee shall comply with the revised version of MACT Subpart DDDDD, and shall not be required to comply with any provisions in this operating permit designated as having MACT Subpart DDDDD as their authority, to the extent that such operating permit provisions would be inconsistent with the applicable provisions of the revised MACT Subpart DDDDD.

002 [40 CFR Part 63 NESHAPS for Source Categories §40 CFR 63.1]**Subpart A--General Provisions****Applicability.**

[Additional authority for this permit condition is also derived from Plan Approval No. 67-05005H]

The Group 016 natural gas-fired natural gas pipeline heaters are subject to 40 CFR Part 63, Subpart DDDDD - National Emission Standards for Hazardous Air Pollutants for Major Sources: Industrial, Commercial, and Institutional Boilers and Process Heaters. The permittee shall comply with all applicable standards, compliance provisions, performance test, monitoring, recordkeeping, and reporting requirements contained at 40 CFR §§63.7480 through 63.7575, including all applicable portions of 40 CFR Part 63, Subpart A - General Provisions. The permittee shall comply with 40 CFR §63.13(a), which requires submission of copies of all requests, reports, applications, submittals, and other communications to both

**SECTION E. Source Group Restrictions.**

the U.S. Environmental Protection Agency (U.S. EPA) and the Department. The U.S. EPA copies shall be forwarded to:

Director
Air Protection Division
U.S. EPA, Region III (3AP00)
1650 Arch Street
Philadelphia, PA 19103-2029

The Department copies shall be forwarded to:

Regional Air Program Manager
PA DEP
Southcentral Regional Office
Air Quality Program
909 Elmerton Avenue
Harrisburg, PA 17110-8200

003 [40 CFR Part 63 NESHAPS for Source Categories §40 CFR 63.7485]

Subpart DDDDD - National Emission Standards for Hazardous Air Pollutants for Major Sources: Industrial, Commercial and Institutional Boilers and Process Heaters.

Am I subject to this subpart?

[Additional authority for this permit condition is also derived from Plan Approval No. 67-05005H]

§63.7480 What is the purpose of this subpart?

MACT Subpart DDDDD establishes national emission limitations and work practice standards for hazardous air pollutants (HAP) emitted from industrial, commercial, and institutional boilers and process heaters located at major sources of HAP. MACT Subpart DDDDD also establishes requirements to demonstrate initial and continuous compliance with the emission limitations and work practice standards.

§63.7485 Am I subject to this subpart?

You are subject to MACT Subpart DDDDD if you own or operate an industrial, commercial, or institutional boiler or process heater as defined in §63.7575 that is located at, or is part of, a major source of HAP, except as specified in §63.7491. For purposes of MACT Subpart DDDDD, a major source of HAP is as defined in §63.2, except that for oil and natural gas production facilities, a major source of HAP is as defined in §63.7575.

[78 FR 7162, Jan. 31, 2013]

§63.7490 What is the affected source of this subpart?

(a) MACT Subpart DDDDD applies to new, reconstructed, and existing affected sources as described in paragraphs (a)(1) and (2) of this section.

(1) [N/A - THE PROCESS HEATERS ARE EACH DEFINED AS A NEW SOURCE PURSUANT TO §63.7490(b)]

(2) The affected source of MACT Subpart DDDDD is each new or reconstructed industrial, commercial, or institutional boiler or process heater, as defined in §63.7575, located at a major source.

(b) A boiler or process heater is new if you commence construction of the boiler or process heater after June 4, 2010, and you meet the applicability criteria at the time you commence construction.

(c) [N/A - THE PROCESS HEATERS ARE EACH DEFINED AS A NEW SOURCE PURSUANT TO §63.7490(b)]

(d) [N/A - THE PROCESS HEATERS ARE EACH DEFINED AS A NEW SOURCE PURSUANT TO §63.7490(b)]

(e) [N/A - NOT AN EGU]

**SECTION E. Source Group Restrictions.**

[76 FR 15664, Mar. 21, 2011, as amended at 78 FR 7162, Jan. 31, 2013]

§63.7491 Are any boilers or process heaters not subject to this subpart?

The types of boilers and process heaters listed in paragraphs (a) through (n) of this section are not subject to MACT Subpart DDDDD. [N/A – NO EXEMPTIONS APPLY]

- (a) [N/A – NOT SUBJECT TO MACT SUBPART UUUUU]
- (b) [N/A – NOT SUBJECT TO MACT SUBPART MM]
- (c) [N/A – NOT A RESEARCH & DEVELOPMENT UNIT]
- (d) [N/A – NOT A HOT WATER HEATER]
- (e) [N/A – NOT A REFINING KETTLE]
- (f) [N/A – NOT SUBJECT TO MACT SUBPART YY]
- (g) [N/A – NOT A BLAST FURNACE STOVE]
- (h) [N/A – NOT PART OF SOURCES SUBJECT TO ANOTHER MACT SUBPART (e.g., JJJ, OOO, PPP, U)]
- (i) [N/A – NOT USED AS A CONTROL DEVICE]
- (j) [N/A – NOT DEFINED AS A TEMPORARY UNIT]
- (k) [N/A – NOT A BLAST FURNACE GAS FUEL-FIRED UNIT]
- (l) [N/A – NOT A UNIT SPECIFICALLY LISTED AS AN AFFECTED SOURCE IN ANY CAA SECTION 129-ESTABLISHED STANDARD(S)]
- (m) [N/A – NOT SUBJECT TO MACT SUBPART EEE]
- (n) [N/A - NOT A RESIDENTIAL BOILER]

[76 FR 15664, Mar. 21, 2011, as amended at 78 FR 7162, Jan. 31, 2013; 80 FR 72806, Nov. 20, 2015]

§63.7495 When do I have to comply with this subpart?

- (a) If you have a new or reconstructed boiler or process heater, you must comply with MACT Subpart DDDDD by April 1, 2013, or upon startup of your boiler or process heater, whichever is later. [NOTE: THE PROCESS HEATERS STARTUP DATE WAS 10/30/16. THEREFORE, THE RELEVANT COMPLIANCE DATE FOR THE PROCESS HEATERS WAS 10/30/16]
- (b) [N/A - THE PROCESS HEATERS ARE EACH DEFINED AS A NEW SOURCE PURSUANT TO §63.7490(b)]
- (c) [N/A - FACILITY IS ALREADY A MAJOR HAPs SOURCE]
- (d) You must meet the notification requirements in §63.7545 according to the schedule in §63.7545 and in 40 CFR Part 63, Subpart A. Some of the notifications must be submitted before you are required to comply with the emission limits and work practice standards in MACT Subpart DDDDD.
- (e) [N/A - NOT A COMMERCIAL OR INDUSTRIAL SOLID WASTE INCINERATION UNIT COVERED BY NSPS SUBPART CCCC OR NSPS SUBPART DDDD]
- (f) [N/A - NOT AN EGU]

**SECTION E. Source Group Restrictions.**

(g) [N/A – NOT USED AS A CONTROL DEVICE]

(h) [N/A - THE PROCESS HEATERS ARE EACH DEFINED AS A NEW SOURCE PURSUANT TO §63.7490(b)]

(i) If you own or operate a new industrial, commercial, or institutional boiler or process heater and have switched fuels or made a physical change to the boiler or process heater that resulted in the applicability of a different subcategory, you must be in compliance with the applicable new source provisions of MACT Subpart DDDDD on the effective date of the fuel switch or physical change.

[76 FR 15664, Mar. 21, 2011, as amended at 78 FR 7162, Jan. 31, 2013; 80 FR 72807, Nov. 20, 2015]

004 [40 CFR Part 63 NESHAPS for Source Categories §40 CFR 63.7499]

Subpart DDDDD - National Emission Standards for Hazardous Air Pollutants for Major Sources: Industrial, Commercial and Institutional Boilers and Process Heaters.

What are the subcategories of boilers and process heaters?

[Additional authority for this permit condition is also derived from Plan Approval No. 67-05005H]

Emission Limitations and Work Practice Standards

§63.7499 What are the subcategories of boilers and process heaters?

The subcategories of boilers and process heaters, as defined in §63.7575 are:

- (a) Pulverized coal/solid fossil fuel units.
- (b) Stokers designed to burn coal/solid fossil fuel.
- (c) Fluidized bed units designed to burn coal/solid fossil fuel.
- (d) Stokers/sloped grate/other units designed to burn kiln dried biomass/bio-based solid.
- (e) Fluidized bed units designed to burn biomass/bio-based solid.
- (f) Suspension burners designed to burn biomass/bio-based solid.
- (g) Fuel cells designed to burn biomass/bio-based solid.
- (h) Hybrid suspension/grate burners designed to burn wet biomass/bio-based solid.
- (i) Stokers/sloped grate/other units designed to burn wet biomass/bio-based solid.
- (j) Dutch ovens/pile burners designed to burn biomass/bio-based solid.
- (k) Units designed to burn liquid fuel that are non-continental units.
- (l) Units designed to burn gas 1 fuels. [NOTE: THE PROCESS HEATERS SATISFY THE DEFINITION OF THIS SUBCATEGORY]
- (m) Units designed to burn gas 2 (other) gases.
- (n) Metal process furnaces.
- (o) Limited-use boilers and process heaters.
- (p) Units designed to burn solid fuel.
- (q) Units designed to burn liquid fuel.

**SECTION E. Source Group Restrictions.**

- (r) Units designed to burn coal/solid fossil fuel.
- (s) Fluidized bed units with an integrated fluidized bed heat exchanger designed to burn coal/solid fossil fuel.
- (t) Units designed to burn heavy liquid fuel.
- (u) Units designed to burn light liquid fuel.

[76 FR 15664, Mar. 21, 2011, as amended at 78 FR 7163, Jan. 31, 2013]

§63.7500 What emission limitations, work practice standards, and operating limits must I meet?

(a) You must meet the requirements in paragraphs (a)(1) through (3) of this section, except as provided in paragraphs (b) through (e) of this section. You must meet these requirements at all times the affected unit is operating, except as provided in paragraph (f) of this section.

(1) You must meet each emission limit and work practice standard in Tables 1 through 3, and 11 through 13 to MACT Subpart DDDDD that applies to your boiler or process heater, for each boiler or process heater at your source, except as provided under §63.7522 [NOTE: OF THESE TABLES, ONLY TABLE 3 APPLIES TO THE PROCESS HEATERS]. The output-based emission limits, in units of pounds per million BTU of steam output, in Tables 1 or 2 to MACT Subpart DDDDD are an alternative applicable only to boilers and process heaters that generate either steam, cogenerate steam with electricity, or both. The output-based emission limits, in units of pounds per megawatt-hour, in Tables 1 or 2 to MACT Subpart DDDDD are an alternative applicable only to boilers that generate only electricity. Boilers that perform multiple functions (cogeneration and electricity generation) or supply steam to common headers would calculate a total steam energy output using Equation 21 of §63.7575 to demonstrate compliance with the output-based emission limits, in units of pounds per million BTU of steam output, in Tables 1 or 2 to MACT Subpart DDDDD. If you operate a new boiler or process heater, you can choose to comply with alternative limits as discussed in paragraphs (a)(1)(i) through (iii) of this section, but on or after January 31, 2016, you must comply with the emission limits in Table 1 to MACT Subpart DDDDD.

RELEVANT §63.7575 DEFINITION: Unit designed to burn gas 1 subcategory includes any boiler or process heater that burns only natural gas, refinery gas, and/or other gas 1 fuels. Gaseous fuel boilers and process heaters that burn liquid fuel for periodic testing of liquid fuel, maintenance, or operator training, not to exceed a combined total of 48 hours during any calendar year, are included in this definition. Gaseous fuel boilers and process heaters that burn liquid fuel during periods of gas curtailment or gas supply interruptions of any duration are also included in this definition.

TABLE 3 REQUIREMENTS

As stated in §63.7500, you must comply with the following applicable work practice standards:

1. [N/A - EACH PROCESS HEATER DOES NOT HAVE A CONTINUOUS OXYGEN TRIM SYSTEM OR A HEAT INPUT CAPACITY OF LESS THAN OR EQUAL TO 5 mmBTU/hr]
2. If your unit is a new or existing boiler or process heater with heat input capacity of less than 10 mmBTU/hr, but greater than 5 mmBTU/hr, in the unit designed to burn gas 1 fuels subcategory, you must meet the following: Conduct a tune-up of the boiler or process heater biennially as specified in §63.7540.
3. [N/A - EACH PROCESS HEATER HAS A HEAT INPUT CAPACITY OF LESS THAN 10 mmBTU/hr]
4. [N/A - THE PROCESS HEATERS ARE EACH DEFINED AS A NEW SOURCE PURSUANT TO §63.7490(b)]
5. [N/A - NO EMISSION LIMITS]
6. [N/A - NO EMISSION LIMITS]

[78 FR 7198, Jan. 31, 2013, as amended at 80 FR 72823, Nov. 20, 2015]

**SECTION E. Source Group Restrictions.**

END OF TABLE 3 REQUIREMENTS

(a)(1)(i) – (a)(1)(iii) [N/A – NO EMISSION LIMITS]

(2) [N/A – NO OPERATING LIMITS]

(3) At all times, you must operate and maintain any affected source (as defined in §63.7490), including associated air pollution control equipment and monitoring equipment, in a manner consistent with safety and good air pollution control practices for minimizing emissions. Determination of whether such operation and maintenance procedures are being used will be based on information available to the Administrator that may include, but is not limited to, monitoring results, review of operation and maintenance procedures, review of operation and maintenance records, and inspection of the source.

(b) As provided in §63.6(g), EPA may approve use of an alternative to the work practice standards in this section.

(c) [N/A - UNITS ARE NOT LIMITED-USE UNITS]

(d) [N/A - EACH PROCESS HEATER HAS A HEAT INPUT CAPACITY OF GREATER THAN 5 mmBTU/hr AND DOES NOT BURN GAS 2 (OTHER) FUELS OR LIGHT LIQUID FUELS]

(e) Boilers and process heaters in the units designed to burn gas 1 fuels subcategory with a heat input capacity of less than or equal to 5 million BTU per hour must complete a tune-up every 5 years as specified in §63.7540. Boilers and process heaters in the units designed to burn gas 1 fuels subcategory with a heat input capacity greater than 5 million BTU per hour and less than 10 million BTU per hour must complete a tune-up every 2 years as specified in §63.7540. Boilers and process heaters in the units designed to burn gas 1 fuels subcategory are not subject to the emission limits in Tables 1 and 2 or 11 through 13 to MACT Subpart DDDDD, or the operating limits in Table 4 to MACT Subpart DDDDD. [NOTE: EACH PROCESS HEATER HAS A HEAT INPUT CAPACITY GREATER THAN 5 mmBTU/hr AND LESS THAN 10 mmBTU/hr; THEREFORE, THEY EACH MUST COMPLETE A TUNE-UP EVERY 2 YEARS (BIENNIALLY) AS SPECIFIED IN §63.7540; SINCE EACH PROCESS HEATER IS IN THE UNITS DESIGNED TO BURN GAS 1 FUELS SUBCATEGORY, THEY ARE NOT SUBJECT TO THE EMISSION LIMITS IN TABLES 1 AND 2 OR 11 THROUGH 13 TO MACT SUBPART DDDDD, OR THE OPERATING LIMITS IN TABLE 4 TO MACT SUBPART DDDDD]

(f) [N/A – NO EMISSION LIMITS]

[76 FR 15664, Mar. 21, 2011, as amended at 78 FR 7163, Jan. 31, 2013; 80 FR 72807, Nov. 20, 2015]

§63.7501 [Reserved]

[80 FR 72807, Nov. 20, 2015]

General Compliance Requirements

§63.7505 What are my general requirements for complying with this subpart?

(a) You must be in compliance with the emission limits, work practice standards, and operating limits in MACT Subpart DDDDD. These emission and operating limits apply to you at all times the affected unit is operating except for the periods noted in §63.7500(f). [NOTE: THE PROCESS HEATERS ARE SUBJECT TO THE WORK PRACTICE STANDARDS IN TABLE 3 TO MACT SUBPART DDDDD; HOWEVER, THE PROCESS HEATERS ARE NOT SUBJECT TO THE EMISSION LIMITS IN TABLES 1 AND 2 OR 11 THROUGH 13 TO MACT SUBPART DDDDD, OR THE OPERATING LIMITS IN TABLE 4 TO MACT SUBPART DDDDD]

(b) [Reserved]

(c) [N/A – NO EMISSION LIMITS]

**SECTION E. Source Group Restrictions.**

(d) [N/A – NO EMISSION LIMITS]

(e) [N/A – NO EMISSION LIMITS]

[76 FR 15664, Mar. 21, 2011, as amended at 78 FR 7164, Jan. 31, 2013; 80 FR 72807, Nov. 20, 2015]

005 [40 CFR Part 63 NESHAPS for Source Categories §40 CFR 63.7510]

Subpart DDDDD - National Emission Standards for Hazardous Air Pollutants for Major Sources: Industrial, Commercial and Institutional Boilers and Process Heaters.

What are my initial compliance requirements and by what date must I conduct them?

[Additional authority for this permit condition is also derived from Plan Approval No. 67-05005H]

Testing, Fuel Analyses, and Initial Compliance Requirements

§63.7510 What are my initial compliance requirements and by what date must I conduct them?

(a) [N/A – NO EMISSION LIMITS]

(b) [N/A – NO EMISSION LIMITS]

(c) [N/A – NO EMISSION LIMITS]

(d) [N/A – NO EMISSION LIMITS]

(e) [N/A - THE PROCESS HEATERS ARE EACH DEFINED AS A NEW SOURCE PURSUANT TO §63.7490(b)]

(f) [N/A – NO EMISSION LIMITS]

(g) For new or reconstructed affected sources (as defined in §63.7490), you must demonstrate initial compliance with the applicable work practice standards in Table 3 to MACT Subpart DDDDD within the applicable annual, biennial, or 5-year schedule as specified in §63.7515(d) following the initial compliance date specified in §63.7495(a). Thereafter, you are required to complete the applicable annual, biennial, or 5-year tune-up as specified in §63.7515(d). [NOTE: THE PROCESS HEATERS ARE SUBJECT TO THE BIENNIAL TUNE-UP REQUIREMENTS SPECIFIED IN §63.7540(a)(11); PURSUANT TO §63.7515(d), THE INITIAL TUNE-UP OF EACH PROCESS HEATER WAS REQUIRED TO BE COMPLETED NO LATER THAN 25 MONTHS AFTER THE INITIAL SOURCE STARTUP; THE INITIAL SOURCE STARTUP DATE WAS 10/30/16; THEREFORE, THE INITIAL TUNE-UP OF EACH PROCESS HEATER WAS REQUIRED TO BE COMPLETED NO LATER THAN 11/30/18; THE INITIAL TUNE-UP OF EACH PROCESS HEATER WAS COMPLETED ON 11/11/16]

(h) [N/A – UNITS HAVE NOT BURNED SOLID WASTE]

(i) [N/A – NOT AN EGU]

(j) [N/A - THE PROCESS HEATERS ARE EACH DEFINED AS A NEW SOURCE PURSUANT TO §63.7490(b)]

(k) For affected sources, as defined in §63.7490, that switch subcategories consistent with §63.7545(h) after the initial compliance date, you must demonstrate compliance within 60 days of the effective date of the switch, unless you had previously conducted your compliance demonstration for this subcategory within the previous 12 months.

[78 FR 7164, Jan. 31, 2013, as amended at 80 FR 72808, Nov. 20, 2015]

§63.7515 When must I conduct subsequent performance tests, fuel analyses, or tune-ups?

(a) [N/A – PERFORMANCE TESTING NOT REQUIRED]

(b) [N/A – PERFORMANCE TESTING NOT REQUIRED]

(c) [N/A – PERFORMANCE TESTING NOT REQUIRED]

**SECTION E. Source Group Restrictions.**

(d) If you are required to meet an applicable tune-up work practice standard, you must conduct an annual, biennial, or 5-year performance tune-up according to §63.7540(a)(10), (11), or (12), respectively. Each annual tune-up specified in §63.7540(a)(10) must be no more than 13 months after the previous tune-up. Each biennial tune-up specified in §63.7540(a)(11) must be conducted no more than 25 months after the previous tune-up. Each 5-year tune-up specified in §63.7540(a)(12) must be conducted no more than 61 months after the previous tune-up. For a new or reconstructed affected source (as defined in §63.7490), the first annual, biennial, or 5-year tune-up must be no later than 13 months, 25 months, or 61 months, respectively, after April 1, 2013 or the initial startup of the new or reconstructed affected source, whichever is later. [NOTE: THE PROCESS HEATERS ARE SUBJECT TO THE BIENNIAL TUNE-UP REQUIREMENTS SPECIFIED IN §63.7540(a)(11)]

(e) [N/A – NO EMISSION LIMITS; AND FUEL ANALYSIS NOT REQUIRED]

(f) [N/A – PERFORMANCE TESTING & FUEL ANALYSIS NOT REQUIRED]

(g) For affected sources (as defined in §63.7490) that have not operated since the previous compliance demonstration and more than one year has passed since the previous compliance demonstration, you must complete the subsequent compliance demonstration, if subject to the emission limits in Tables 1, 2, or 11 through 13 to MACT Subpart DDDDD, no later than 180 days after the re-start of the affected source and according to the applicable provisions in §63.7(a)(2) as cited in Table 10 to MACT Subpart DDDDD. You must complete a subsequent tune-up by following the procedures described in §63.7540(a)(10)(i) through (vi) and the schedule described in §63.7540(a)(13) for units that are not operating at the time of their scheduled tune-up. [NOTE: THE PROCESS HEATERS ARE NOT SUBJECT TO THE EMISSION LIMITS IN TABLES 1 AND 2 OR 11 THROUGH 13 TO MACT SUBPART DDDDD]

(h) [N/A – PERFORMANCE TESTING NOT REQUIRED]

(i) [N/A – NO CO CEMS]

[78 FR 7165, Jan. 31, 2013, as amended at 80 FR 72808, Nov. 20, 2015]

§63.7520 What stack tests and procedures must I use?

(a) – (f) [N/A – PERFORMANCE TESTING NOT REQUIRED]

[76 FR 15664, Mar. 21, 2011, as amended at 78 FR 7166, Jan. 31, 2013]

§63.7521 What fuel analyses, fuel specification, and procedures must I use?

(a) – (i) [N/A – FUEL ANALYSIS NOT REQUIRED SINCE THERE ARE NO EMISSION LIMITS]

[78 FR 7167, Jan. 31, 2013, as amended at 80 FR 72808, Nov. 20, 2015]

§63.7522 Can I use emissions averaging to comply with this subpart?

(a) – (k) [N/A – NO EMISSION LIMITS]

[76 FR 15664, Mar. 21, 2011, as amended at 78 FR 7168, Jan. 31, 2013; 80 FR 72809, Nov. 20, 2015]

§63.7525 What are my monitoring, installation, operation, and maintenance requirements?

(a) [N/A – NO EMISSION LIMITS]

(b) [N/A – NO EMISSION LIMITS]

(c) [N/A – NO OPACITY OPERATING LIMIT]

(d) [N/A – NO CMS REQUIRED]

**SECTION E. Source Group Restrictions.**

- (e) [N/A – NO FLOW MONITORING SYSTEM REQUIRED]
- (f) [N/A – NO PRESSURE MONITORING SYSTEM REQUIRED]
- (g) [N/A – NO pH MONITORING SYSTEM REQUIRED]
- (h) [N/A – NO ESP]
- (i) [N/A – NO SORBENT INJECTION RATE MONITORING SYSTEM REQUIRED]
- (j) [N/A – NO FABRIC FILTER BAG LEAK DETECTION SYSTEM]
- (k) [N/A - UNITS ARE NOT LIMITED-USE UNITS]
- (l) [N/A – NO EMISSION LIMITS]
- (m) [N/A – NO EMISSION LIMITS]

[76 FR 15664, Mar. 21, 2011, as amended at 78 FR 7171, Jan. 31, 2013; 80 FR 72810, Nov. 20, 2015]

§63.7530 How do I demonstrate initial compliance with the emission limitations, fuel specifications and work practice standards?

- (a) [N/A – NO EMISSION LIMITS]
- (b) [N/A – NO EMISSION LIMITS]
- (c) [N/A – NO EMISSION LIMITS]
- (d) [Reserved]
- (e) [N/A - AN ENERGY ASSESSMENT IS NOT REQUIRED SINCE THE PROCESS HEATERS ARE EACH DEFINED AS A NEW SOURCE PURSUANT TO §63.7490(b)]
- (f) You must submit the Notification of Compliance Status containing the results of the initial compliance demonstration according to the requirements in §63.7545(e).
- (g) [N/A – UNIT DOES NOT BURN “OTHER GAS 1 FUEL” AS DEFINED AT §63.7575]
- (h) [N/A – NO EMISSION LIMITS]
- (i) [N/A – NO SO₂ CEMS]

[76 FR 15664, Mar. 21, 2011, as amended at 78 FR 7174, Jan. 31, 2013; 80 FR 72811, Nov. 20, 2015]

§63.7533 Can I use efficiency credits earned from implementation of energy conservation measures to comply with this subpart?

- (a) – (g) [N/A – NO EMISSION LIMITS]

[76 FR 15664, Mar. 21, 2011, as amended at 78 FR 7178, Jan. 31, 2013; 80 FR 72812, Nov. 20, 2015]

Continuous Compliance Requirements

§63.7535 Is there a minimum amount of monitoring data I must obtain?

- (a) - (d) [N/A – NO CMS REQUIRED]

**SECTION E. Source Group Restrictions.**

[76 FR 15664, Mar. 21, 2011, as amended at 78 FR 7179, Jan. 31, 2013; 80 FR 72812, Nov. 20, 2015]

§63.7540 How do I demonstrate continuous compliance with the emission limitations, fuel specifications and work practice standards?

(a) You must demonstrate continuous compliance with each emission limit in Tables 1 and 2 or 11 through 13 to MACT Subpart DDDDD, the work practice standards in Table 3 to MACT Subpart DDDDD, and the operating limits in Table 4 to MACT Subpart DDDDD, that applies to you according to the methods specified in Table 8 to MACT Subpart DDDDD and paragraphs (a)(1) through (19) of this section. [NOTE: OF THESE TABLES, ONLY TABLE 3 (WORK PRACTICE STANDARDS) TO MACT SUBPART DDDDD APPLIES TO THE PROCESS HEATERS]

(1) [N/A – NO EMISSION/OPERATING LIMITS]

(2) [N/A – NO EMISSION LIMITS]

(3) [N/A – NO EMISSION LIMITS]

(4) [N/A – NO EMISSION LIMITS]

(5) [N/A – NO EMISSION LIMITS]

(6) [N/A – NO EMISSION LIMITS]

(7) [N/A – NO FABRIC FILTER BAG LEAK DETECTION SYSTEM]

(8) [N/A – NO EMISSION LIMITS]

(9) [N/A – NO PM CPMS/CEMS]

(10) If your boiler or process heater has a heat input capacity of 10 mmBTU/hr or greater, you must conduct an annual tune-up of the boiler or process heater to demonstrate continuous compliance as specified in paragraphs (a)(10)(i) through (vi) of this section. You must conduct the tune-up while burning the type of fuel (or fuels in case of units that routinely burn a mixture) that provided the majority of the heat input to the boiler or process heater over the 12 months prior to the tune-up. This frequency does not apply to limited-use boilers and process heaters, as defined in §63.7575, or units with continuous oxygen trim systems that maintain an optimum air to fuel ratio. [NOTE: EACH PROCESS HEATER HAS A HEAT INPUT CAPACITY OF LESS THAN 10 mmBTU/hr; THEREFORE, A BIENNIAL TUNE-UP OF EACH PROCESS HEATER MUST BE CONDUCTED AS SPECIFIED IN PARAGRAPHS (a)(10)(i) THROUGH (vi), IMMEDIATELY BELOW, TO DEMONSTRATE CONTINUOUS COMPLIANCE PURSUANT TO §63.7540(a)(11) OF THIS SECTION]

(i) As applicable, inspect the burner, and clean or replace any components of the burner as necessary (you may perform the burner inspection any time prior to the tune-up or delay the burner inspection until the next scheduled unit shutdown). Units that produce electricity for sale may delay the burner inspection until the first outage, not to exceed 36 months from the previous inspection. At units where entry into a piece of process equipment or into a storage vessel is required to complete the tune-up inspections, inspections are required only during planned entries into the storage vessel or process equipment;

(ii) Inspect the flame pattern, as applicable, and adjust the burner as necessary to optimize the flame pattern. The adjustment should be consistent with the manufacturer's specifications, if available;

(iii) Inspect the system controlling the air-to-fuel ratio, as applicable, and ensure that it is correctly calibrated and functioning properly (you may delay the inspection until the next scheduled unit shutdown). Units that produce electricity for sale may delay the inspection until the first outage, not to exceed 36 months from the previous inspection;

(iv) Optimize total emissions of CO. This optimization should be consistent with the manufacturer's specifications, if available, and with any NOX requirement to which the unit is subject;

(v) Measure the concentrations in the effluent stream of CO in parts per million, by volume, and oxygen in volume percent,

**SECTION E. Source Group Restrictions.**

before and after the adjustments are made (measurements may be either on a dry or wet basis, as long as it is the same basis before and after the adjustments are made). Measurements may be taken using a portable CO analyzer; and

(vi) Maintain on-site and submit, if requested by the Administrator, a report containing the information in paragraphs (a)(10)(vi)(A) through (C) of this section.

(A) The concentrations of CO in the effluent stream in parts per million by volume (ppmv), and oxygen in volume percent, measured at high fire or typical operating load, before and after the tune-up of the boiler or process heater;

(B) A description of any corrective actions taken as a part of the tune-up; and

(C) The type and amount of fuel used over the 12 months prior to the tune-up, but only if the unit was physically and legally capable of using more than one type of fuel during that period. Units sharing a fuel meter may estimate the fuel used by each unit.

(11) If your boiler or process heater has a heat input capacity of less than 10 mmBTU/hr (except as specified in paragraph (a)(12) of this section), you must conduct a biennial tune-up of the boiler or process heater as specified in paragraphs (a)(10)(i) through (vi) of this section to demonstrate continuous compliance. [NOTE: EACH PROCESS HEATER HAS A HEAT INPUT CAPACITY OF LESS THAN 10 mmBTU/hr; THEREFORE, A BIENNIAL TUNE-UP OF EACH PROCESS HEATER MUST BE CONDUCTED TO DEMONSTRATE CONTINUOUS COMPLIANCE]

(12) [N/A - EACH PROCESS HEATER DOES NOT HAVE A CONTINUOUS OXYGEN TRIM SYSTEM OR A HEAT INPUT CAPACITY OF LESS THAN OR EQUAL TO 5 mmBTU/hr]

(13) If the unit is not operating on the required date for a tune-up, the tune-up must be conducted within 30 calendar days of startup.

(14) [N/A – NO EMISSION LIMITS]

(15) [N/A – NO EMISSION LIMITS]

(16) [N/A – NO EMISSION LIMITS]

(17) [N/A – NO EMISSION LIMITS]

(18) [N/A – NO EMISSION LIMITS]

(19) [N/A – NO EMISSION LIMITS]

(b) You must report each instance in which you did not meet each emission limit and operating limit in Tables 1 through 4 or 11 through 13 to MACT Subpart DDDDD that apply to you. These instances are deviations from the emission limits or operating limits, respectively, in MACT Subpart DDDDD. These deviations must be reported according to the requirements in §63.7550. [NOTE: OF THESE TABLES, ONLY TABLE 3 (WORK PRACTICE STANDARDS) TO MACT SUBPART DDDDD APPLIES TO THE PROCESS HEATERS]

(c) [N/A – NO EMISSION LIMITS]

(d) [N/A – NO EMISSION LIMITS]

[78 FR 7179, Jan. 31, 2013, as amended at 80 FR 72813, Nov. 20, 2015]

§63.7541 How do I demonstrate continuous compliance under the emissions averaging provision?

(a) – (b) [N/A – NO EMISSION LIMITS]

[76 FR 15664, Mar. 21, 2011, as amended at 78 FR 7182, Jan. 31, 2013]

**SECTION E. Source Group Restrictions.****# 006 [40 CFR Part 63 NESHAPS for Source Categories §40 CFR 63.7545]****Subpart DDDDD - National Emission Standards for Hazardous Air Pollutants for Major Sources: Industrial, Commercial and Institutional Boilers and Process Heaters.****What notifications must I submit and when?**

[Additional authority for this permit condition is also derived from Plan Approval No. 67-05005H]

Notification, Reports, and Records

§63.7545 What notifications must I submit and when?

(a) You must submit to the Administrator all of the notifications in §§63.7(b) and (c), 63.8(e), (f)(4) and (6), and 63.9(b) through (h) that apply to you by the dates specified.

(b) [N/A - EACH OF THE PROCESS HEATER'S STARTUP DATE WAS ON OR AFTER JANUARY 31, 2013]

(c) As specified in §63.9(b)(4) and (5), if you startup your new or reconstructed affected source on or after January 31, 2013, you must submit an Initial Notification not later than 15 days after the actual date of startup of the affected source. [NOTE: THE ACTUAL STARTUP DATE OF THE PROCESS HEATERS WAS 10/30/16; THEREFORE, THE INITIAL NOTIFICATION WAS REQUIRED TO HAVE BEEN SUBMITTED NO LATER THAN 11/14/16; THE PERMITTEE SUBMITTED THE INITIAL NOTIFICATION TO DEP VIA A LETTER DATED 6/15/18 (RECEIVED BY DEP ON 6/15/18) AND SUBMITTED TO U.S. EPA VIA CEDRI ON 6/15/18]

(d) [N/A – PERFORMANCE TESTING NOT REQUIRED]

(e) If you are required to conduct an initial compliance demonstration as specified in §63.7530, you must submit a Notification of Compliance Status according to §63.9(h)(2)(ii). For the initial compliance demonstration for each boiler or process heater, you must submit the Notification of Compliance Status, including all performance test results and fuel analyses, before the close of business on the 60th day following the completion of all performance test and/or other initial compliance demonstrations for all boiler or process heaters at the facility according to §63.10(d)(2). The Notification of Compliance Status report must contain all the information specified in paragraphs (e)(1) through (8) of this section, as applicable. If you are not required to conduct an initial compliance demonstration as specified in §63.7530(a), the Notification of Compliance Status must only contain the information specified in paragraphs (e)(1) and (8) of this section and must be submitted within 60 days of the compliance date specified at §63.7495(a). [NOTE: THE NOTIFICATION OF COMPLIANCE STATUS (NOCS) WAS REQUIRED TO HAVE BEEN SUBMITTED BEFORE THE CLOSE OF BUSINESS ON THE 60th DAY FOLLOWING THE COMPLETION OF THE INITIAL TUNE-UP FOR ALL PROCESS HEATERS AT THE FACILITY; SINCE THE INITIAL TUNE-UP OF ALL PROCESS HEATERS WAS COMPLETED ON 11/11/16, THE NOCS WAS REQUIRED TO HAVE BEEN SUBMITTED BEFORE THE CLOSE OF BUSINESS ON 1/10/17; THE PERMITTEE SUBMITTED THE NOCS TO U.S. EPA AND DEP VIA A LETTER DATED 7/30/19 (RECEIVED BY DEP ON 8/02/19)]

(1) A description of the affected unit(s) including identification of which subcategories the unit is in, the design heat input capacity of the unit, a description of the add-on controls used on the unit to comply with MACT Subpart DDDDD, description of the fuel(s) burned, including whether the fuel(s) were a secondary material determined by you or the U.S. EPA through a petition process to be a non-waste under §241.3 of this chapter (Chapter I), whether the fuel(s) were a secondary material processed from discarded non-hazardous secondary materials within the meaning of §241.3 of this chapter (Chapter I), and justification for the selection of fuel(s) burned during the compliance demonstration.

(2) [N/A – PERFORMANCE TESTING/FUEL ANALYSIS NOT REQUIRED]

(3) [N/A – NO EMISSION LIMITS]

(4) [N/A – NO EMISSION LIMITS]

(5) [N/A – NO EMISSION LIMITS]

(6) [N/A - NOT REQUIRED TO CONDUCT AN INITIAL COMPLIANCE DEMONSTRATION AS SPECIFIED IN §63.7530(a); SEE §63.7545(e), ABOVE]

**SECTION E. Source Group Restrictions.**

(7) [N/A - NOT REQUIRED TO CONDUCT AN INITIAL COMPLIANCE DEMONSTRATION AS SPECIFIED IN §63.7530(a); SEE §63.7545(e), ABOVE]

(8) In addition to the information required in §63.9(h)(2), your Notification of Compliance Status must include the following certification(s) of compliance, as applicable, and signed by a responsible official:

(i) "This facility completed the required initial tune-up for all of the boilers and process heaters covered by 40 CFR Part 63 Subpart DDDDD at this site according to the procedures in §63.7540(a)(10)(i) through (vi)."

(ii) "This facility has had an energy assessment performed according to §63.7530(e)."

(iii) Except for units that burn only natural gas, refinery gas, or other gas 1 fuel, or units that qualify for a statutory exemption as provided in Section 129(g)(1) of the Clean Air Act, include the following: "No secondary materials that are solid waste were combusted in any affected unit."

(f) If you operate a unit designed to burn natural gas, refinery gas, or other gas 1 fuels that is subject to MACT Subpart DDDDD, and you intend to use a fuel other than natural gas, refinery gas, gaseous fuel subject to another Subpart of 40 CFR Part 60, 61, 63, or 65, or other gas 1 fuel to fire the affected unit during a period of natural gas curtailment or supply interruption, as defined in §63.7575, you must submit a notification of alternative fuel use within 48 hours of the declaration of each period of natural gas curtailment or supply interruption, as defined in §63.7575. The notification must include the information specified in paragraphs (f)(1) through (5) of this section.

(1) Company name and address.

(2) Identification of the affected unit.

(3) Reason you are unable to use natural gas or equivalent fuel, including the date when the natural gas curtailment was declared or the natural gas supply interruption began.

(4) Type of alternative fuel that you intend to use.

(5) Dates when the alternative fuel use is expected to begin and end.

(g) [N/A – UNIT DOES NOT BURN SOLID WASTE]

(h) If you have switched fuels or made a physical change to the boiler or process heater and the fuel switch or physical change resulted in the applicability of a different subcategory, you must provide notice of the date upon which you switched fuels or made the physical change within 30 days of the switch/change. The notification must identify:

(1) The name of the owner or operator of the affected source, as defined in §63.7490, the location of the source, the boiler(s) and process heater(s) that have switched fuels, were physically changed, and the date of the notice.

(2) The currently applicable subcategory under this subpart.

(3) The date upon which the fuel switch or physical change occurred.

[76 FR 15664, Mar. 21, 2011, as amended at 78 FR 7183, Jan. 31, 2013; 80 FR 72814, Nov. 20, 2015]

§63.7550 What reports must I submit and when?

(a) You must submit each report in Table 9 to MACT Subpart DDDDD that applies to you.

TABLE 9 REQUIREMENTS

As stated in §63.7550, you must comply with the following requirements for reports:

**SECTION E. Source Group Restrictions.**

You must submit a compliance report. The report must contain

- a. Information required in §63.7550(c)(1) through (5); and
- b. [N/A – NO EMISSION/OPERATING LIMITS & NO STARTUP/SHUTDOWN WORK PRACTICE STANDARDS]; and
- c. [N/A – NO EMISSION/OPERATING LIMITS & NO STARTUP/SHUTDOWN WORK PRACTICE STANDARDS]; and
- d. [N/A – NO EMISSION/OPERATING LIMITS]

You must submit the report semiannually, annually, biennially, or every 5 years according to the requirements in §63.7550(b).

[76 FR 15664, Mar. 21, 2011, as amended at 78 FR 7205, Jan. 31, 2013; 80 FR 72830, Nov. 20, 2015]

END OF TABLE 9 REQUIREMENTS

(b) Unless the EPA Administrator has approved a different schedule for submission of reports under §63.10(a), you must submit each report, according to paragraph (h) of this section, by the date in Table 9 to MACT Subpart DDDDD and according to the requirements in paragraphs (b)(1) through (4) of this section. For units that are subject only to a requirement to conduct subsequent annual, biennial, or 5-year tune-ups according to §63.7540(a)(10), (11), or (12), respectively, and not subject to emission limits or Table 4 operating limits, you may submit only an annual, biennial, or 5-year compliance report, as applicable, as specified in paragraphs (b)(1) through (4) of this section, instead of a semi-annual compliance report. [NOTE: SINCE THE PROCESS HEATERS ARE SUBJECT ONLY TO A REQUIREMENT TO CONDUCT SUBSEQUENT BIENNIAL TUNE-UPS ACCORDING TO §63.7540(a)(11), AND NOT SUBJECT TO EMISSION LIMITS OR TABLE 4 OPERATING LIMITS, A BIENNIAL COMPLIANCE REPORT SUBMISSION IS REQUIRED FOR THE PROCES HEATERS]

(1) The first semi-annual compliance report must cover the period beginning on the compliance date that is specified for each boiler or process heater in §63.7495 and ending on June 30 or December 31, whichever date is the first date that occurs at least 180 days after the compliance date that is specified for your source in §63.7495. If submitting an annual, biennial, or 5-year compliance report, the first compliance report must cover the period beginning on the compliance date that is specified for each boiler or process heater in §63.7495 and ending on December 31 within 1, 2, or 5 years, as applicable, after the compliance date that is specified for your source in §63.7495. [NOTE: PURSUANT TO §63.7550(b), THE PERMITTEE IS REQUIRED TO SUBMIT BIENNIAL COMPLIANCE REPORTS; THE FIRST BIENNIAL COMPLIANCE REPORT COVERED THE PERIOD OF 10/30/16 THROUGH 12/31/17]

(2) The first semi-annual compliance report must be postmarked or submitted no later than July 31 or January 31, whichever date is the first date following the end of the first calendar half after the compliance date that is specified for each boiler or process heater in §63.7495. The first annual, biennial, or 5-year compliance report must be postmarked or submitted no later than January 31. [NOTE: THE FIRST BIENNIAL COMPLIANCE REPORT COVERING THE PERIOD OF 10/30/16 THROUGH 12/31/17 WAS REQUIRED TO HAVE BEEN POSTMARKED OR SUBMITTED NO LATER THAN 1/31/18; THE PERMITTEE SUBMITTED THE FIRST BIENNIAL COMPLIANCE REPORT (COVERING THE PERIOD OF 10/30/16 THROUGH 12/31/18) TO U.S. EPA AND THE DEP VIA A LETTER DATED 7/31/19; A COPY OF THE LETTER WAS RECEIVED BY DEP ON 8/02/19]

(3) Each subsequent semi-annual compliance report must cover the semiannual reporting period from January 1 through June 30 or the semiannual reporting period from July 1 through December 31. Annual, biennial, and 5-year compliance reports must cover the applicable 1-, 2-, or 5-year periods from January 1 to December 31. [NOTE: A SUBSEQUENT BIENNIAL COMPLIANCE REPORT SUBMISSION IS REQUIRED FOR THE PROCESS HEATERS]

(4) Each subsequent semi-annual compliance report must be postmarked or submitted no later than July 31 or January 31, whichever date is the first date following the end of the semi-annual reporting period. Annual, biennial, and 5-year compliance reports must be postmarked or submitted no later than January 31. [NOTE: THE SUBSEQUENT BIENNIAL COMPLIANCE REPORTS MUST BE POSTMARKED OR SUBMITTED NO LATER THAN JANUARY 31]

**SECTION E. Source Group Restrictions.**

(5) [N/A - SUBMISSION OF SEMI-ANNUAL COMPLIANCE REPORTS IS NOT REQUIRED]

(c) A compliance report must contain the following information depending on how the facility chooses to comply with the limits set in this rule.

(1) If the facility is subject to the requirements of a tune-up, you must submit a compliance report with the information in paragraphs (c)(5)(i) through (iii) of this section, (xiv) and (xvii) of this section, and paragraph (c)(5)(iv) of this section for limited-use boiler or process heater.

(2) [N/A – FUEL ANALYSES NOT REQUIRED]

(3) [N/A – NO EMISSION LIMITS]

(4) [N/A – NO EMISSION LIMITS]

(5)(i) Company and Facility name and address.

(ii) Process unit information, emissions limitations, and operating parameter limitations.

(iii) Date of report and beginning and ending dates of the reporting period.

(iv) The total operating time during the reporting period.

(v) – (xii) [N/A – NO EMISSION LIMITS]

(xiv) Include the date of the most recent tune-up for each unit subject to only the requirement to conduct an annual, biennial, or 5-year tune-up according to §63.7540(a)(10), (11), or (12) respectively. Include the date of the most recent burner inspection if it was not done annually, biennially, or on a 5-year period and was delayed until the next scheduled or unscheduled unit shutdown.

(xv) – (xvi) [N/A – NO EMISSION LIMITS]

(xvii) Statement by a responsible official with that official's name, title, and signature, certifying the truth, accuracy, and completeness of the content of the report.

(xviii) [N/A – NO EMISSION LIMITS]

(d) [N/A – NO EMISSION/OPERATING LIMITS]

(e) [N/A – NO EMISSION/OPERATING LIMITS]

(f) - (g) [Reserved]

(h) You must submit the reports according to the procedures specified in paragraphs (h)(1) through (3) of this section.

(1) [N/A – NO EMISSION LIMITS]

(2) [N/A – NO EMISSION LIMITS]

(3) You must submit all reports required by Table 9 of MACT Subpart DDDDD electronically to the U.S. EPA via the CEDRI. CEDRI can be accessed through the U.S. EPA's CDX. You must use the appropriate electronic report in CEDRI for MACT Subpart DDDDD. Instead of using the electronic report in CEDRI for MACT Subpart DDDDD, you may submit an alternate electronic file consistent with the XML schema listed on the CEDRI Web site (<http://www.epa.gov/ttn/chief/cedri/index.html>), once the XML schema is available. If the reporting form specific to MACT Subpart DDDDD is not available in CEDRI at the time that the report is due, you must submit the report to the Administrator at the appropriate address listed in §63.13. You must begin submitting reports via CEDRI no later than 90 days after the form becomes available in CEDRI.

**SECTION E. Source Group Restrictions.**

[78 FR 7183, Jan. 31, 2013, as amended at 80 FR 72814, Nov. 20, 2015]

§63.7555 What records must I keep?

(a) You must keep records according to paragraphs (a)(1) through (3) of this section.

(1) A copy of each notification and report that you submitted to comply with MACT Subpart DDDDD, including all documentation supporting any Initial Notification or Notification of Compliance Status or semiannual (or biennial) compliance report that you submitted, according to the requirements in §63.10(b)(2)(xiv).

(2) Records of performance tests, fuel analyses, or other compliance demonstrations and performance evaluations as required in §63.10(b)(2)(vii).

(3) [N/A - UNITS ARE NOT LIMITED-USE UNITS]

(b) [N/A – NO EMISSION LIMITS/CEMS/COMS/CMS]

(c) [N/A – NO EMISSION LIMITS]

(d) [N/A – NO EMISSION LIMITS]

(e) [N/A – NO EMISSION LIMITS]

(f) [N/A – NO EMISSION LIMITS]

(g) [N/A – NO EMISSION LIMITS]

(h) If you operate a unit in the unit designed to burn gas 1 subcategory that is subject to MACT Subpart DDDDD, and you use an alternative fuel other than natural gas, refinery gas, gaseous fuel subject to another subpart under 40 CFR Part 63, other gas 1 fuel, or gaseous fuel subject to another Subpart of 40 CFR Part 60, 61, 63, or 65, you must keep records of the total hours per calendar year that alternative fuel is burned and the total hours per calendar year that the unit operated during periods of gas curtailment or gas supply emergencies.

[76 FR 15664, Mar. 21, 2011, as amended at 78 FR 7185, Jan. 31, 2013; 80 FR 72816, Nov. 20, 2015]

§63.7560 In what form and how long must I keep my records?

(a) Your records must be in a form suitable and readily available for expeditious review, according to §63.10(b)(1).

(b) As specified in §63.10(b)(1), you must keep each record for 5 years following the date of each occurrence, measurement, maintenance, corrective action, report, or record.

(c) You must keep each record on-site, or they must be accessible from on-site (for example, through a computer network), for at least 2 years after the date of each occurrence, measurement, maintenance, corrective action, report, or record, according to §63.10(b)(1). You can keep the records off-site for the remaining 3 years.

Other Requirements and Information

§63.7565 What parts of the General Provisions apply to me?

Table 10 to MACT Subpart DDDDD shows which parts of the General Provisions in §§63.1 through 63.15 apply to you.

§63.7575 What definitions apply to this subpart?

Terms used in 40 CFR Part 63, Subpart DDDDD - National Emission Standards for Hazardous Air Pollutants for Major Sources: Industrial, Commercial, and Institutional Boilers and Process Heaters, as well as Section E (Group 012) of this Title V operating permit are defined in the Clean Air Act (CAA); in §63.2 (General Provisions); and in §63.7575.

**SECTION E. Source Group Restrictions.**

[78 FR 15664, Mar. 21, 2011, as amended at 78 FR 7163, Jan. 31, 2013; 80 FR 72817, Nov. 20, 2015]

***** Permit Shield in Effect. *****



SECTION F. Alternative Operation Requirements.

No Alternative Operations exist for this Title V facility.



SECTION G. Emission Restriction Summary.

No emission restrictions listed in this section of the permit.

**SECTION H. Miscellaneous.**

NOTE: The capacities/throughputs listed in Sections A, D and H are for informational use only and should not be used as enforceable limitations.

The listed capacity/throughput for Source ID 050 of 30.4 mmBTU/hr in Sections A and D represents the cumulative capacity/throughput of all four (4) natural gas (NG)-fired NG pipeline heaters.

List of Additional Responsible Official(s) for Brunner Island Steam Electric Station:

Scott Blair
 VP - PJM
 1005 Brandon Shores Road
 Baltimore, MD 21226
 410.787.5017
 Scott.Blair@talenergy.com

The following sources of minor significance have been exempted from work practice standards, and testing, monitoring, record keeping, and reporting requirements:

- * Air conditioning and exhaust fan ventilation vents
- * Portable space heaters
- * Electric ovens and heaters
- * Internal combustion engines powering mobile sources
- * Office equipment (e.g., copiers, printers, communication equipment)
- * Detergent washing of metal parts (no HAPs or VOC)
- * Station storage tanks or containers (no HAPs or VOC)
- * Laundry operations for employees' clothing (no HAPs or VOC)
- * Construction or demolition of building or structures
- * Clearing of land
- * Maintenance activities, equipment and supplies
- * Machine shop equipment (e.g., lathe, drills, grinder, welder)
- * Fire protection equipment and training activities
- * Garbage compactors and waste barrels
- * Stationary material handling systems
- * Other electrically-operated equipment
- * Portable water treatment equipment
- * Service and maintenance shop (e.g., cars and trucks)
- * Inert gas emissions (e.g., argon, helium and nitrogen)
- * Propane or natural gas tanks or containers
- * Lubricating / transformer / hydraulic oil reservoir vents
- * Water storage tank breather vents (roof or underground)
- * Turbine hydrogen seal system vents
- * Steam safety relief valve vents
- * Boiler steam blowdown vents
- * Sanitary sewer stack vents
- * Emission monitor building gas stack (e.g., calibration gas)
- * Roof wind turbine vents (natural circulation)
- * Deaerator tank condenser vents
- * Sandblasting (various and sundry locations)
- * Painting (various and sundry locations)
- * Welding (various and sundry locations)
- * Boiler chemical cleaning activities
- * Oil / chemical drum storage (sealed containers)
- * Process water treatment, storage or cooling systems
- * Surface impoundments (treatment / cooling / run-off ponds)
- * Sewage treatment facilities

**SECTION H. Miscellaneous.**

- * Diesel fuel / fuel oil storage tank vents (< 40,000 gallons)
- * Station DC battery recharging areas
- * Hydrogen storage bottles
- * Turbine oil vapor extractor vents
- * Secondary Coal Crushing
- * Reclaim Crushing Operations
- * Unit 3 dry sorbent injection system
- * Roadways (formerly Source ID 101)
- * Reclaim Coal Stocking (formerly Source ID 123)
- * Ground Coal Distribution & Storage (formerly Source ID 130)

Source ID 131 - Limestone Material Handling Operations consists of the following components:

Railcar Unloading System:

- HOP-11 Unloading Hopper (200 TPH)
- HOP-12 Unloading Hopper (200 TPH)
- FDRB-11 Feeder Belt (1,250 TPH)
- FDRB-12 Feeder Belt (1,250 TPH)
- DS-10 Dust suppression system (Dry Fog)
- CNV-10 Stackout conveyor (2,000 TPH)
- Chut-10 Telescoping Chute (2,000 TPH)
- SP-10 Active Limestone Storage Pile (9,576 ton capacity)
- SP-11 Inactive Limestone Storage Pile (191,520 ton capacity)

Limestone Storage Pile and Handling System:

- HOP-13 Limestone Reclaim Hopper (500 TPH)
- HOP-14 Limestone Reclaim Hopper (500 TPH)
- FDRV-13 Vibratory Pan Feeder (500 TPH)
- FDRV-14 Vibratory Pan Feeder (500 TPH)
- DS-11 Dust Suppression System (Dry Fog)
- CNV-11 Conveyor (400 TPH)
- CNV-12 Conveyor (500 TPH)
- DC-12 Limestone Silo Dust Collector (500 acfm) {indoor exhausting}
- DC-13 Limestone Silo Dust Collector (500 acfm) {indoor exhausting}

Source ID 132 - Gypsum Material Handling Operations - consists of the following components:

- CNV-50A Gypsum Conveyor (270 TPH)
- CNV-50B Gypsum Conveyor (270 TPH)
- SP-50 Backup Storage Pile (130,650 tons)
- SP-51 Commercial Storage Pile (195,980 tons)
- SP-52 Blending Pile (4,000 tons)

Source ID 133 - Wastewater Treatment Plant (WWTP) System - consists of the following component:

- DC-14 Lime Silo Dust Collector (2000 acfm)

RFD*Online RFD #1538 (plan approval exemption approved online 8/03/10) authorized the construction of two dry sorbent storage silos for hydrated lime and/or trona injection for SO₃ control. The storage silos are each equipped with a dedicated bin vent collector for PM control. Sorbent (hydrated lime and/or trona) is pneumatically transferred from trucks to the storage silos and from the storage silos to a utility boiler's injection point.

Source ID 150 - Refined Coal System - consists of the following components:

Enclosed Pug Mill Mixer

**SECTION H. Miscellaneous.**

Four Conveyor Belts (UNITs 2100, 2300, 5100, and C5A)

540-gallon Liquid Sorbent Day Storage Tank

30-ton Solid Sorbent Day Storage Bin* controlled by a dedicated bin vent collector (Source ID C150A)

20-ton Solid Sorbent Day Storage Bin* controlled by a dedicated bin vent collector (Source ID C150B)

* along with an associated Enclosed Screw Conveyor

4400-gallon Liquid Sorbent Bulk Storage Tank

150-ton Solid Sorbent Bulk Storage Silo controlled by a dedicated bin vent collector (Source ID C150C)

The following serves as a permitting history description of some of the Source IDs:

Source ID 031A was previously the subject of Operating Permit No. 67-306-005, RACT Operating Permit No. 67-2005, Plan Approval Nos. 67-05005D, 67-05005H & 67-05005I, and Acid Rain Permit (ORIS:3140).

Source ID 032 was previously the subject of Operating Permit No. 67-306-001A, RACT Operating Permit No. 67-2005, Plan Approval Nos. 67-05005A, 67-05005D, 67-05005F, 67-05005H & 67-05005I, and Acid Rain Permit (ORIS:3140).

Source ID 033A was previously the subject of Operating Permit No. 67-306-003, RACT Operating Permit No. 67-2005, Plan Approval Nos. 67-05005C, 67-05005D, 67-05005H & 67-05005I, and Acid Rain Permit (ORIS:3140).

Source ID 034 was previously the subject of RACT Operating Permit No. 67-2005.

Source ID 035 was previously the subject of RACT Operating Permit No. 67-2005.

Source ID 036 was previously the subject of RACT Operating Permit No. 67-2005.

Source ID 037 was previously the subject of Plan Approval No. 67-05005D.

Source ID 038 was previously the subject of Plan Approval No. 67-05005D.

Source ID 050 was previously the subject of Plan Approval No. 67-05005H.

Source ID 110 was previously the subject of Plan Approval No. 67-05005B.

Source ID 127 was previously the subject of Operating Permit No.67-399-020.

Source ID 131 was previously the subject of Plan Approval No.67-05005E.

Source ID 132 was previously the subject of Plan Approval No.67-05005E.

Source ID 133 was previously the subject of Plan Approval No.67-05005E.

Source ID 140 was previously the subject of Plan Approval No.67-05005I.

Source ID 141 was previously the subject of Plan Approval No.67-05005I.

Source ID 301 was previously the subject of Plan Approval No. 67-05005H.

Each utility boiler (Source IDs 031A, 032 and 033A) has two associated No. 2 fuel oil-fired coal mill heaters (i.e., duct burners) each having a maximum rated heat input capacity of 9.9 mmBTU/hr that supply hot air to dry the bituminous coal during its pulverization prior to its injection into the boilers. This plan approval authorizes the combustion of natural gas fuel by the coal mill heaters. The air emissions from the coal mill heaters are included with the three utility boilers (Source IDs 031A, 032 and 033A). The coal mill heaters are not subject to the MACT standards contained at 40 CFR Part 63, Subpart DDDDD – National Emission Standards for Hazardous Air Pollutants for Major Sources: Industrial, Commercial, and Institutional Boilers and Process Heaters (MACT Subpart DDDDD).

**SECTION H. Miscellaneous.**

The following serves as a description of the emergency engines:

Source IDs 037 & 038

Manufacturer: John Deere Co.

Model Number: JU6H-UF50

What the Engine Drives: Fire pump

Ignition Type: Compression ignition

Fuel Type: Diesel fuel oil (or No. 2 fuel oil)

Rated Engine Power Output Capacity: 210 HP

Rated Generator Power Output Capacity (kW): N/A

Engine Displacement: (6.8 L) / (6 cylinders) = 1.1 L / cylinder

Model Year: 2007

Construction Date: 8/01/09

Applicable Federal Subpart: NSPS Subpart IIII & MACT Subpart ZZZZ

Source ID 401

Manufacturer: Cummins

Model Number: 300DFCB

What the Engine Drives: Emergency generator

Ignition Type: Compression ignition

Fuel Type: Diesel fuel oil (or No. 2 fuel oil)

Rated Engine Power Output Capacity: 420 HP

Rated Generator Power Output Capacity: 300 kW

Engine Displacement: (14.0 L) / (6 cylinders) = 2.3 L / cylinder

Model Year: 1990

Construction Date: ~ 1/01/90

Applicable Federal Subpart: MACT Subpart ZZZZ

Source ID 402

Manufacturer: Cummins

Model Number: NH-220-GS

What the Engine Drives: Emergency generator

Ignition Type: Compression ignition

Fuel Type: Diesel fuel oil (or No. 2 fuel oil)

Rated Engine Power Output Capacity: 220 HP

Rated Generator Power Output Capacity: 125 kW

Engine Displacement: unknown

Model Year: 1967

Construction Date: ~ 1/01/67

Applicable Federal Subpart: MACT Subpart ZZZZ

Source ID 403

Manufacturer: Deere & Co.

Model Number: unknown

What the Engine Drives: Sump pump

Ignition Type: Compression ignition

Fuel Type: Diesel fuel oil (or No. 2 fuel oil)

Rated Engine Power Output Capacity: 50 HP

Rated Generator Power Output Capacity (kW): N/A

Engine Displacement: unknown

Model Year: unknown

Construction Date: pre-2006

Applicable Federal Subpart: MACT Subpart ZZZZ

Source ID 404

Manufacturer: Caterpillar

Model Number: CAT 3408

**SECTION H. Miscellaneous.**

What the Engine Drives: Fire pump
Ignition Type: Compression ignition
Fuel Type: Diesel fuel oil (or No. 2 fuel oil)
Rated Engine Power Output Capacity: 498 HP
Rated Generator Power Output Capacity (kW): N/A
Engine Displacement: unknown
Model Year: 1982
Construction Date: ~ 1/01/82
Applicable Federal Subpart: MACT Subpart ZZZZ



***** End of Report *****
